

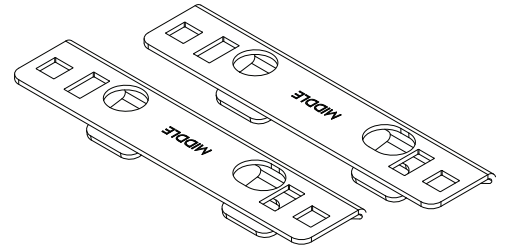

TOYOTA HIACE SLWB CROSSBAR BASE FITMENT



MAX 3 BAR EVENLY DISTRIBUTED LOAD: 120KG.
IMPORTANT: THIS LOAD CAPACITY INCLUDES WEIGHT OF CROSSBARS (5KG EACH).

Important information:

- Do not exceed the maximum roof load capacity of your vehicle (found in vehicle owners manual). If lower than roof rack system, always use the lower of the two figures. The mass of the roof rack and any bar accessories fitted, must be subtracted from the maximum carrying capacity to determine actual payload capacity. As a guide each cross bar weighs 5kgs. Example: Maximum Carrying capacity of 120kgs, Subtract 15kgs for a three bar system. Actual Payload is 105kgs.
 - Narrow and heavy loads are to be carried near the feet. - Loads which overhang shall conform to any relevant state laws.
 - Check tie down strap tension every 50kms as loads can shift and resettle
 - Do not use elastic straps to secure a load. Surfboards or similar large wind resistive loads should NOT be carried side by side but on top of each other. Each should be secured independently to the front and rear roof bar.
 - Specialised equipment carriers for specific products should always be used. I.e Ladder rack, bike and kayak carriers
- Note:** The handling characteristics of a vehicle will change when a carrier system is fitted. Driving techniques should be altered to allow for these changes, reducing speed, cornering and allowing longer braking distances.
- Roof bars can be removed when not in use.

Parts list:

Item	Part	3 Bar
1	M6 x 30mm Button Head Screw - F008	12
2	M6 Spring Washer - F012	12
3	M6 x 16mm Flat Washer - F011	12
4	M8 x 20mm loctite Pan Head Screw	12
5	M8 x 17mm Washer - F011	12
6	Middle Common Bracket - C144	6
7	4mm Allen Tool - C028	1

Required tools:

- 1 - 10mm Socket Wrench.
- 2 - 4mm Allen Key (provided).
- 3 - 5mm Allen Key.
- 4 - 17mm Spanner.
- 5 - Butyl Mastic.
- 6 - PH4 Phillips Head Screw Driver.

Required kits (as separate):

- Crossbar x3 1650mm
- 10mm Spacer x 2
- Crossbar Mount Kit x 3

80mm Mount

Step 1

Identify the factory mounts on the roof of the vehicle. Using a 10mm socket wrench undo the mounts. You must alternate loosening the bolts progressively to ensure mounts are not dislodged on the inside of the vehicle.

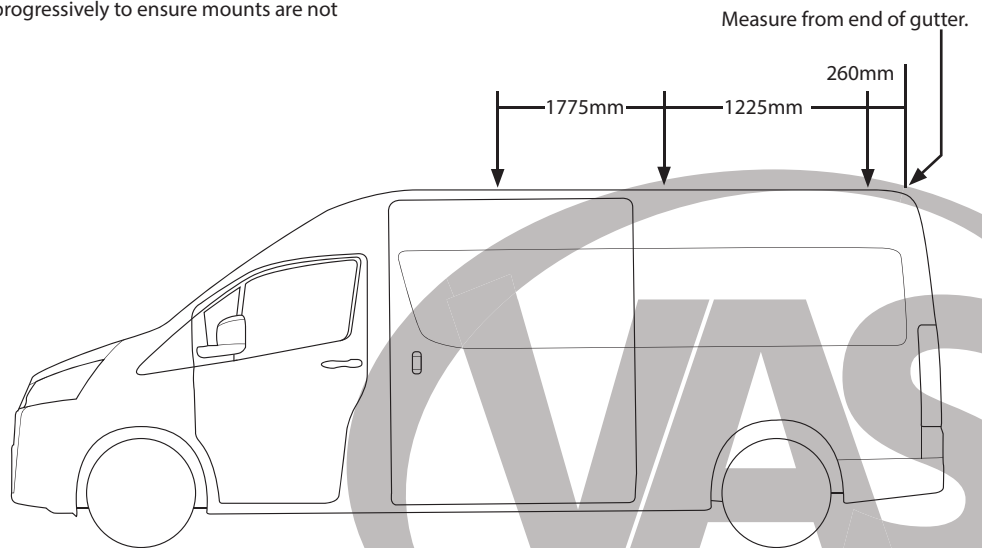
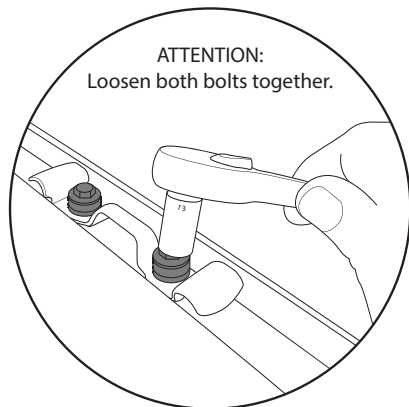

VAN RACKING MOUNT FITMENT

Step 2

Remove the factory mounts from your roof. Apply butyl mastic in and around the holes in the roof to ensure your roof remains water tight.

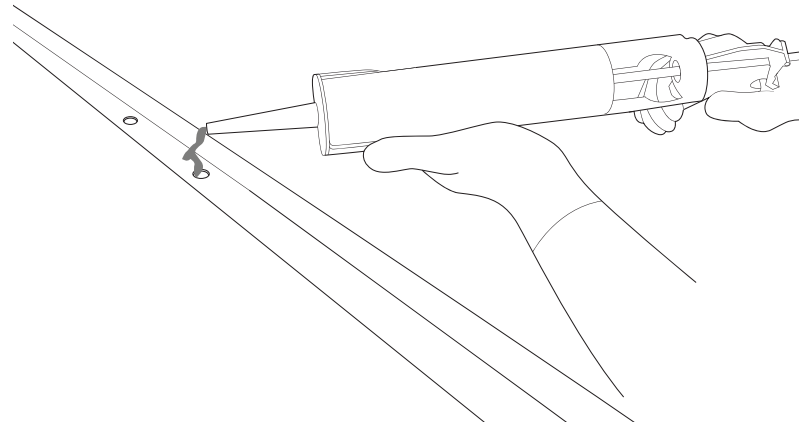
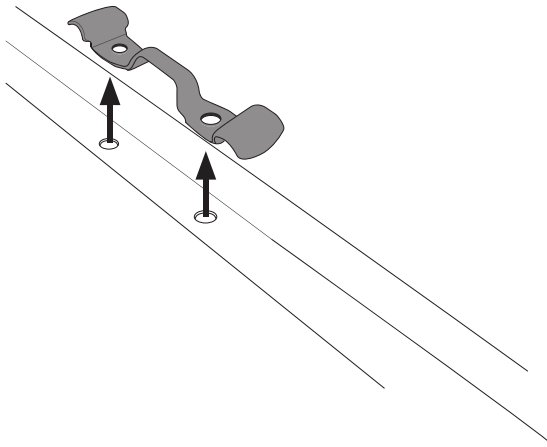

Step 3

1 - Install the M8 hardware into each bracket. 2 - Place the brackets into position onto the mounting points of your roof. The arrows on the front and rear brackets face the front of your vehicle. 3 - Tighten the brackets in place with a PH4 Phillips head screwdriver.

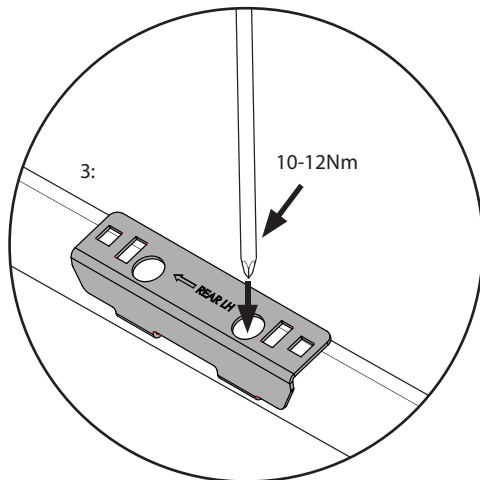
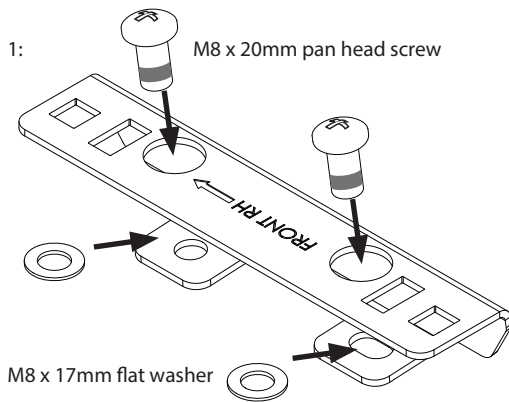

2:

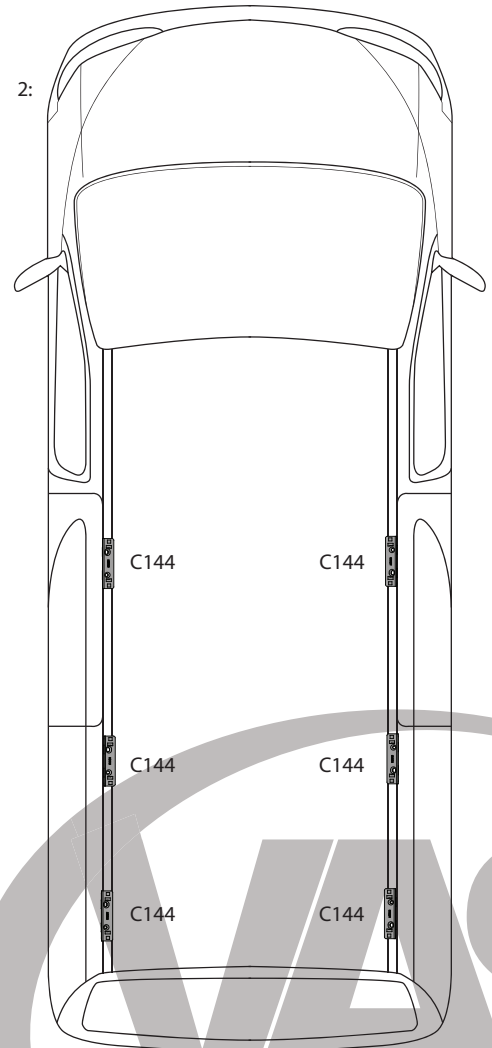

VAN RACKING MOUNT FITMENT

Step 4

Complete crossbar mount kits as specified in their instructions. Place the crossbars onto the installed brackets in the roof. Fix in place with the M6 hardware provided and tighten with an allen key.

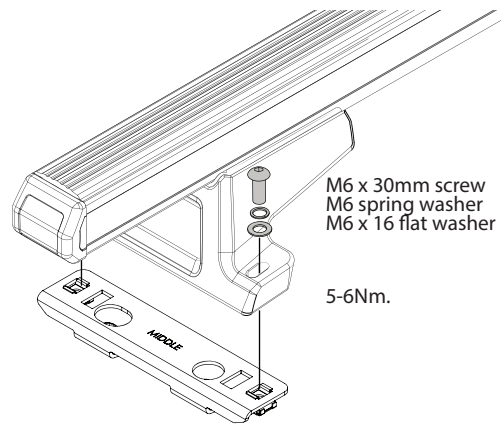

NOTE

ATTENTION:
Kit for standard legs only.
Thoroughly check all fasteners are secure before driving away.
Front crossbar mount require 10mm spacer.

