



RHINO-RACK®

RVP89 Leg Fitting Supplement ISUZU D-Max X-Terrain Gen3

REFER TO YOUR VEHICLE OWNERS MANUAL & BASE KIT INSTRUCTION FOR THE SYSTEM CARRYING CAPACITY

PARTS/TOOLS REQUIRED:

- T1 - 10mm Spanner/Socket Wrench
- T2 - Marker
- T3 - Saw (flush bar only - if converting overhang bars)

REFER RCP29-BK INSTRUCTION FOR BASE KIT LEG ATTACHMENT HARDWARE 1., 2., 3.

1 FLUSH CROSS BARS

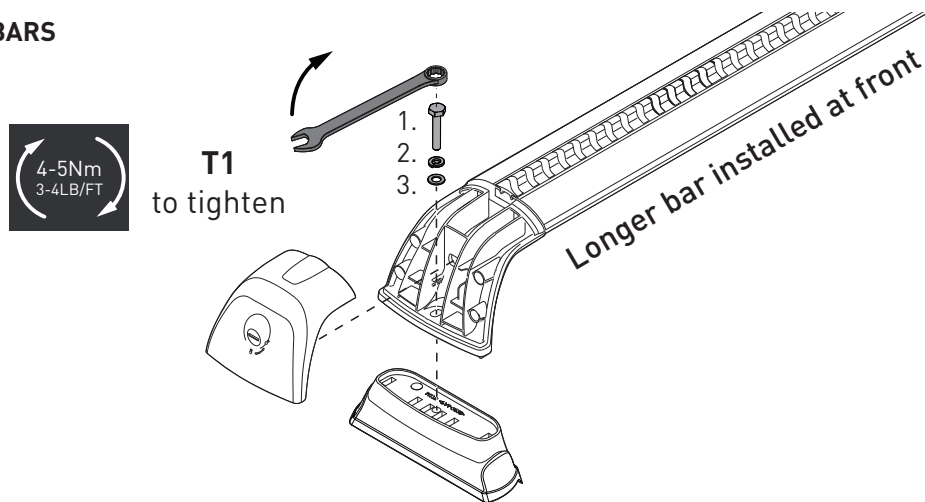

Note: Overhang crossbars can be cut to length to make flush bars fit this vehicle.

1. Mark the centre of the Front and Rear Overhang Vortex Bar
2. Measure from the centre of the front & rear bar out to the below desired lengths and mark on both ends
3. Carefully cut the bar at these markings using a Saw with an Alloy Cutting Blade.

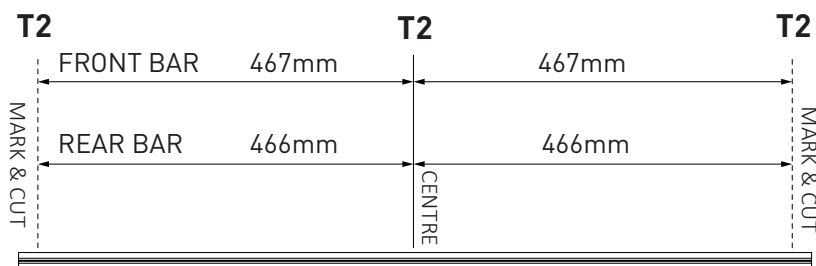

Note for dealers when altering RSP kits:
 Add 38mm to sports bar measurement for RVL.
 Add 40mm to sports bar measurement for RVH.

T3 to cut

