



RHINO-RACK

Aerodynamic & Heavy Duty Roof Rack Systems

RTS508 Range Rover Sport - Rhino Tracks

Place these instructions in the vehicle's glove box after installation is complete.

Important: Please read these instructions carefully prior to installation. Please refer to your fitting instruction to ensure that the roof racks are installed in the correct locations. Check the contents of kit before commencing fitment and report any discrepancies

Parts List

Maximum carrying capacity: 75kg

Item	Component Name	Qty	Part No.
1	LEFT Track	1	A362
2	RIGHT Track	1	A362
3	FL End Cap	2	M253
4	FR End Cap	2	M254
5	M6 x 20 Security Screw	6	B062
6	M6 Spring Washer	6	W003
7	M6 x 12.5mm Flat Washer	6	W004
8	M6 Retaining Washer	2	C461
9	5mm Security Allen Key	1	H021
10	Fitting Instruction	1	RS276

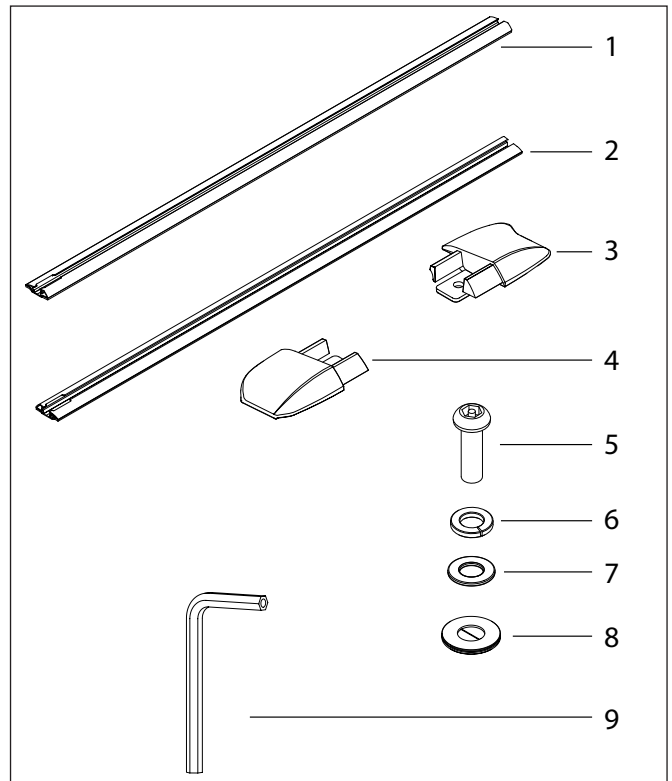

Care Instruction:

Clean vehicle roof and gutter prior to fitting Rhino Tracks.

Tools & Materials Required.

Marking pen.
5mm Security Allen key, provided in kit.
Flat Head screw driver.
Measuring tape.
Hack saw.

Layout

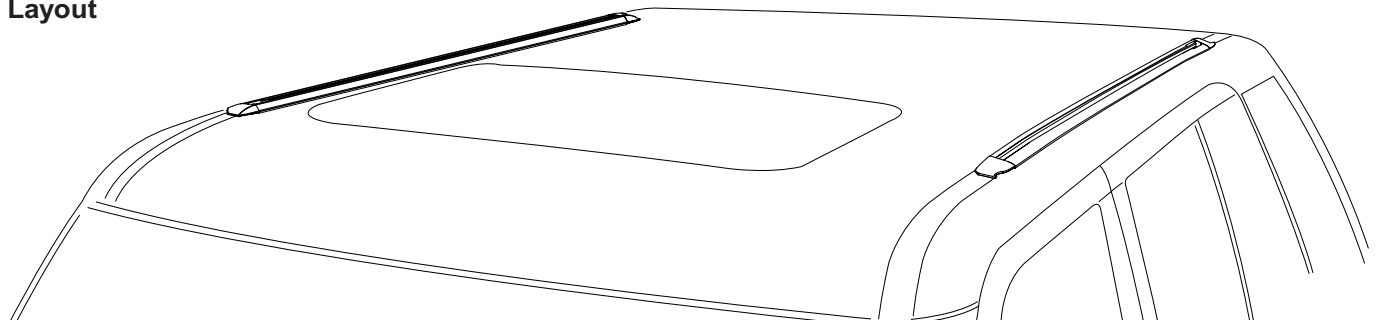

1

Front RIGHT shown.

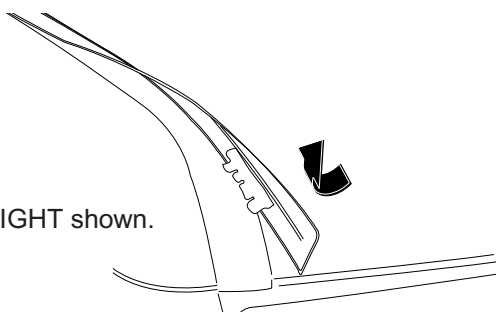

Remove the original roof trim by lifting at the front and twisting in an outward direction to unhook the plastic clips. Be careful not to use too much force otherwise the clips may break.



RTS508 Range Rover Sport - Rhino Tracks

2

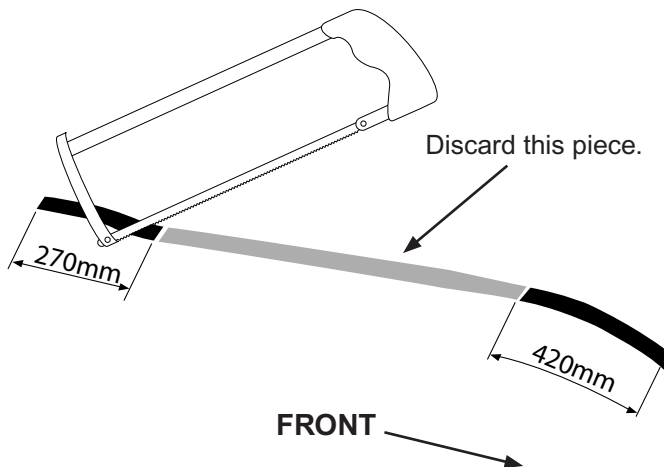

Cut each roof channel strip at 420mm from the FRONT and 270mm from the REAR. These two pieces will sit under the end caps of the track. A hacksaw will need to be used to cut the strip.

3

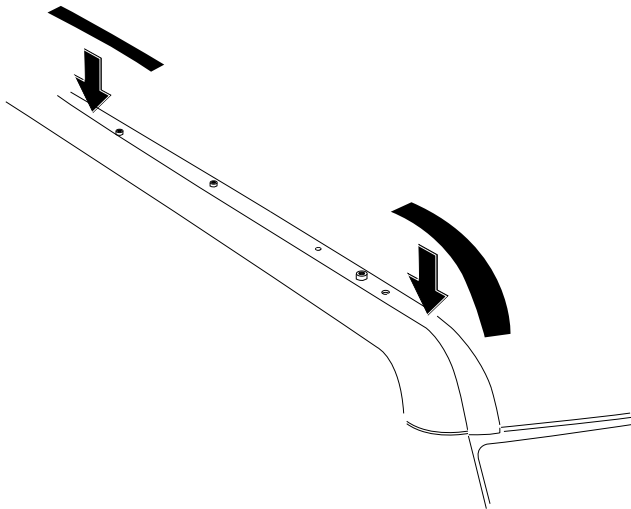

Clip the cut pieces of trim back into the roof channel.

4

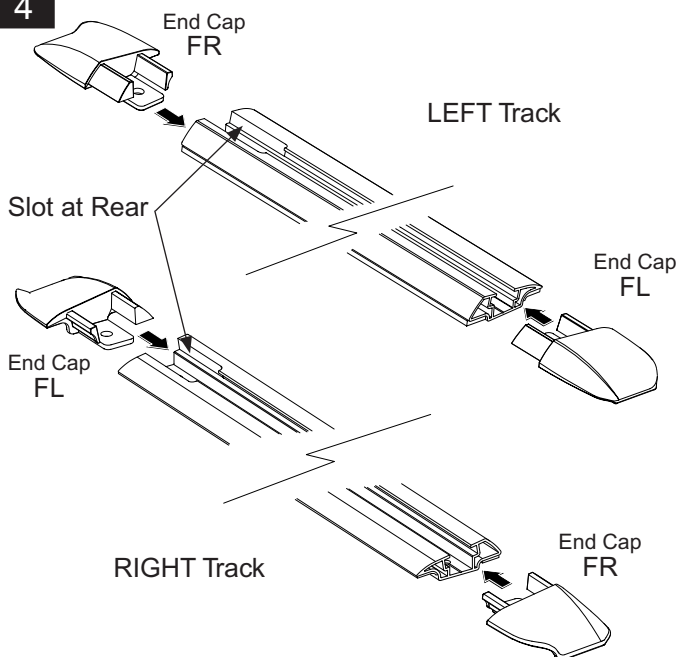

Push the end caps into the tracks. The end caps are marked on the underside. Fit the correct end caps as shown in the adjacent diagram. The cut out slot on top of the Track lies at the rear of the roof.

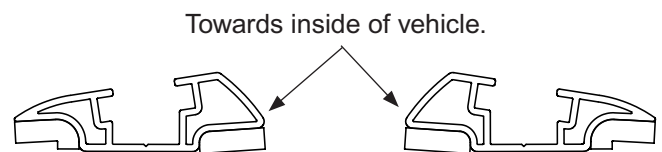

Tracks viewed from the REAR.

LEFT

RIGHT



RTS508 Range Rover Sport - Rhino Tracks

5

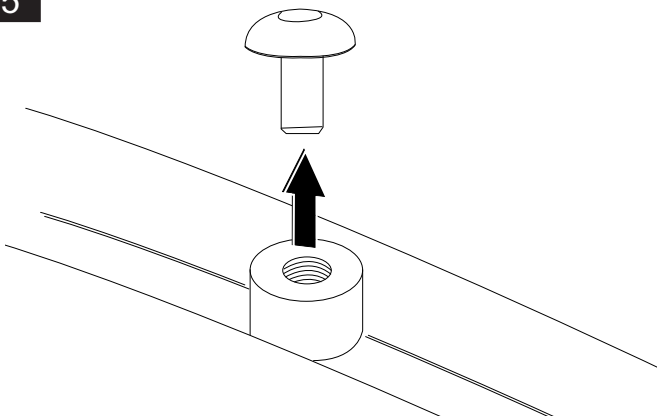

Using a flat head screwdriver carefully remove the three plastic plugs in each side of the roof channel. This exposes an M6 threaded nutsert for the tracks to be fastened.

6

Peel off the white protective strips from the underside of the tracks before fastening them in place.

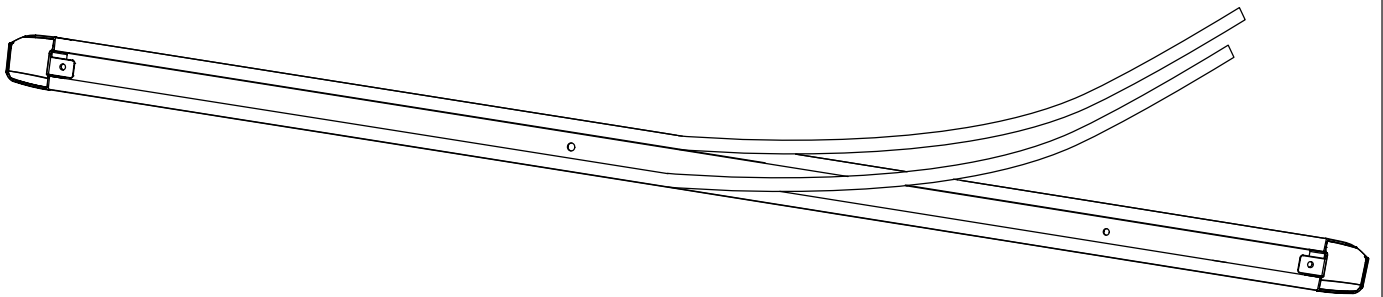

7

Place the end screws through the track and end cap holes. **Only the centre screw has the retaining washer underneath the track.** Place the foam side of the retaining washer against the nutsert on the vehicle. Fasten the the track to the nutserts in the roof channel. **Tighten M6 screws to 3-4N/m** with the supplied Allen key.

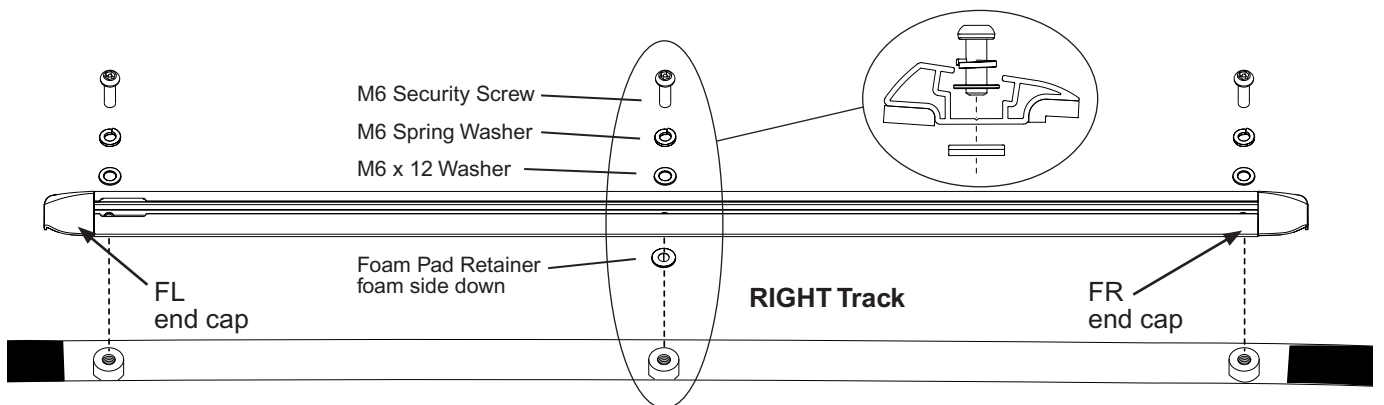

8

Once tightened down, the track end caps will put light pressure on and neatly cover the original roof trim.

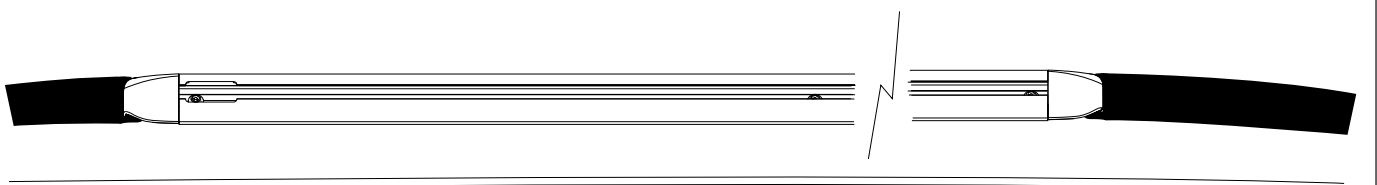



Important Information

Maximum carrying capacity: 75kg

Recommendations:

It is essential that all bolt connections be checked after driving a short distance when you first install your cross bars.

Bolt connections should be checked again at regular intervals (probably once a week is enough, depending on road conditions, usage, loads and distances travelled). You should also check the cross bars each time they are refitted.

Make sure to fasten your load securely. Please ensure that all loads are evenly distributed and that the centre of gravity is kept as low as possible.

Use only non-stretch fastening ropes or straps:

Sensitivity to cross winds, behaviour in curves and braking:

The handling characteristics of the vehicle, changes when you transport a load on the roof. For safety reasons, we recommend you exercise extreme care when transporting wind-resisting loads; special consideration must be taken into account when braking.

Please remove cross bars when putting vehicle through an automatic car wash:

Load Ratings:

Maximum permissible load is 75kg per pair of cross bars (include the weight of the cross bars, 5kg). When cross bars are to be used in off-road conditions, please build a safety factor of 1.5 into this load limit. Although the cross bars are tested and approved to AS1235-2000, Australian road conditions can be much more rigorous. However, increasing the number of cross bars does not increase the vehicles maximum permissible roof loading.

Note for Dealers and Fitters:

It is your responsibility to ensure instructions are given to the end user or client.

Rhino-Rack
3 Pike Street, Rydalmere,
NSW 2116, Australia.
(Ph) (02) 9638 4744
(Fax) (02) 9638 4822

Document No: RS276
Prepared By: Craig Jones
Authorised By: Gary England

Issue No: 01
Issue Date: 13/12/2006

These instructions remain the property of Fetovu Pty Ltd T/as Rhino-Rack and may not be used or changed for any other purpose than intended.