



# RHINO-RACK®

ISUZU D-MAX GEN 3 / MAZDA BT-50 GEN 3

HOLDEN COLORADO GEN 2 / ISUZU  
D-MAX (LS-U/LS-M/X-RUNNER) GEN 2

## Base Kit - RCP71F-BK

### Important:

1. Check the Rhino-Rack website to ensure you have the latest issue of these instructions.
2. Please refer to your fitting instruction to ensure that the roof racks are installed in the correct locations.
3. Check the contents of kit before commencing fitment and report any discrepancies.
4. Place these instructions in the vehicle's glove box after installation is complete.
5. These instructions must be followed for warranty to be upheld.

**Fit Time:** 1 hour

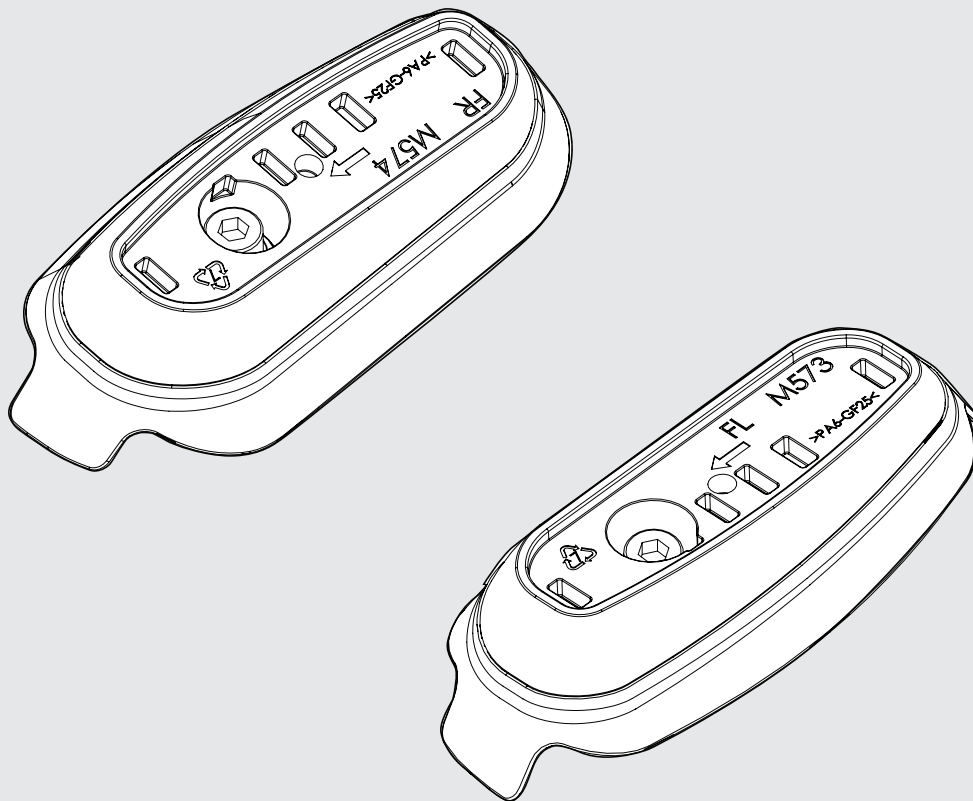

**Rhino-Rack AUSTRALIA**  
22A Hanson Pl,  
Eastern Creek, NSW, 2766  
(02) 8846 1900  
rhinorack.com.au

**Rhino-Rack USA**  
Unit D, 2450 Airport Blvd,  
Aurora, CO, 80011  
877-744-6622  
rhinorack.com

**Rhino-Rack CANADA**  
19100 Airport Way  
Pitt Meadows, BC V3Y 0E2  
rhinorack.ca

Document No: R2747  
Issue No: 03  
Issue Date: 18/10/21

## Carrying Capacity

Check your vehicle owners hand book for vehicle maximum carrying capacity. Please ensure you use the vehicle manufacturer's maximum roof allowance if it is lower than the figure listed in this instruction.

Load must be evenly distributed over the system.

VISIT THE ONLINE  
LOAD LIMIT  
CALCULATOR FOR  
CURRENT LOAD DATA

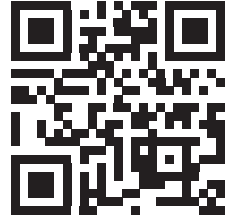

### SINGLE BAR ONLY

DYNAMIC CROSS BAR LOAD LIMIT: *USE THE VEHICLE MANUFACTURER'S MAXIMUM ROOF ALLOWANCE IF IT IS LOWER THAN THE FIGURE LISTED			
	 CARGO	 SYSTEM WEIGHT	 LOAD LIMIT
	UP TO <b>7 KG</b> <b>15 lbs</b>	+ <b>3 KG</b> <b>7 lbs</b>	
		OR	 *VEHICLE MANUFACTURER'S ROOF LOAD LIMIT

### SINGLE SUPPORT BAR - In combination with Roof Racks fitted to another section of vehicle

DYNAMIC CROSS BAR LOAD LIMIT: *USE THE VEHICLE MANUFACTURER'S MAXIMUM ROOF ALLOWANCE IF IT IS LOWER THAN THE FIGURE LISTED			
	 CARGO	 SYSTEM WEIGHT	 LOAD LIMIT
	UP TO <b>37 KG</b> <b>81 lbs</b>	+ <b>3 KG</b> <b>7 lbs</b>	
		OR	 *VEHICLE MANUFACTURER'S ROOF LOAD LIMIT



#### Cargo Load Limit

Total permissible weight allowed on top, and attached to roof racks whilst the vehicle is in motion.

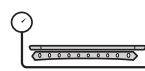

#### System Weight

Total weight of the roof rack system. (Crossbars, Backbone, Platform)



#### Max System Load Capacity

Please ensure you use the vehicle manufacturer's maximum roof allowance if it is lower than the figure listed in the fitting chart.



#### Vehicle Manufacturer's Load Limit

Total permissible weight attached to the roof of the car. This is inclusive of the weight of the roof rack system.

## Warning

- Check part number or kit is correct for use with your vehicle.
- Do not attempt to fit the rack system to your vehicle unless you fully understand these fitting instructions. Please direct any questions regarding fitting to the dealer from where the roof racks were purchased.
- Off-road conditions can be much more rigorous. Extreme care must be taken on any driven path that does not contain a surface protection layer (tar/bitumen).
- Roof racks must be removed when vehicle is put through an automatic car wash.
- **With utility/pickup vehicles, the cabin and the tub/tray/canopy move independently. Roof racks and vehicle can be damaged if the item transported is rigidly fixed at points on both the cabin and tub/tray/canopy. Instead, rigidly fix to either the cabin roof racks or the tub/tray/canopy roof racks. A single bar fitted to another section of the vehicle should be used as a support for longer loads only.**
- Always ensure you fasten your load securely.
- Use only non-stretch fastening ropes or straps to attach cargo to your load.

### SINGLE SUPPORT BAR WARNING

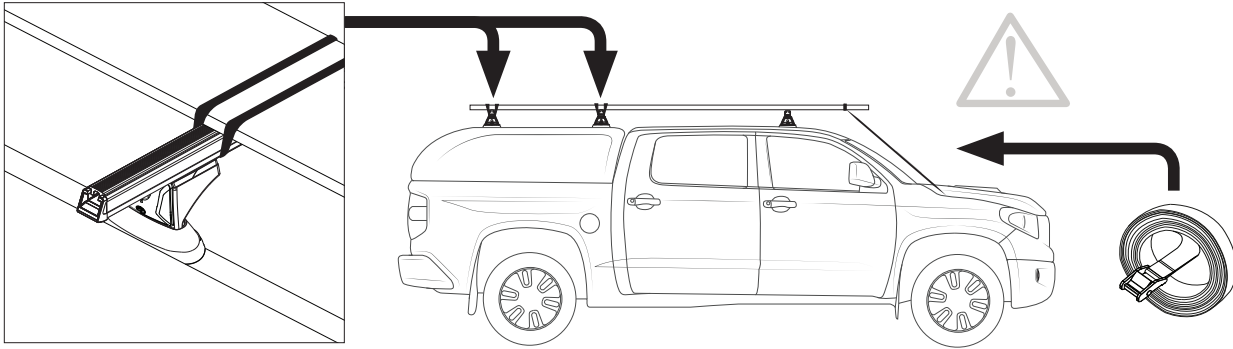

### In service maintenance checks

---

- All bolt connections should be checked after driving a short distance when you first install your roof racks.
- All bolted connections should be checked again at regular intervals (weekly is recommended, depending on road conditions, usage, loads and distances travelled).
- All bolted connections should be checked each time they are re-fitted.
- Off-road conditions are more rigorous. Check all bolted connections and your load more regularly.
- Ensure that your vehicle manufacturer's GVM, and gross axle weights are not exceeded (refer to vehicle owner's manual).

#### Torque Settings

Unless stated otherwise in these instructions, all fasteners should be set to the following torque settings:

M6: 4-5Nm (3-4lbs/ft),

M8: 8-10Nm (6-7.5lbs/ft)

M10: 16-18Nm (12-13lbs/ft).











### Note for Dealers and Fitters

---

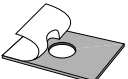
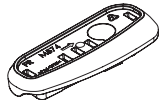
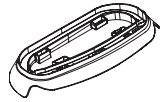
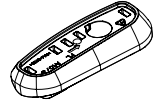
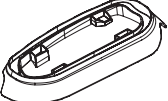
It is your responsibility to ensure these fitting instructions are given to the end user or client. These instructions remain the property of Rhino-Rack Australia Pty. Ltd. and may not be used or changed for any other purpose than intended.

## RCP71F-BK Instructions

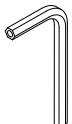
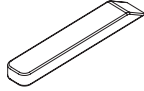
### Parts List

M8 x 30mm SHCS  <b>A x2</b>	M8 Spring Washer  <b>B x2</b>	M8 Flat Washer  <b>C x2</b>	7mm x 4mm O-ring  <b>D x2</b>
Butyl Patch  <b>E x2</b>	Front Right Pad (FR) fin-loc  <b>F x1</b>	Front Right Skirt (FR)  <b>G x1</b>	Front Left Pad (FL) fin-loc  <b>H x1</b>
Front Left Skirt (FL)  <b>I x1</b>	Pad Cover Plate  <b>J x2</b>	M6 x 30mm Hex Setscrew  <b>K x2</b>	M6 Spring Washer  <b>L x2</b>
M6 x 16mm Flat Washer  <b>M x2</b>	6mm Allen Key  <b>N x1</b>	Nylon Scraper  <b>O x1</b>	Instruction  <b>P x1</b>

### Tools Required:

- T1 - Masking Tape
- T2 - Tape Measure
- T3 - Pencil/Marker
- T4 - Chisel
- T5 - Mallet
- T6 - Flat head Screwdriver
- T7 - Knife
- T8 - Cold Galvanising paint
- T9 - Small Paint Brush
- T10 - Caulking gun with Butyl Mastic (for Colorado Gen2 / D-Max (LS-U/LS-M/X-Runner) Gen2 only)

**1** Repeat to opposite side of vehicle

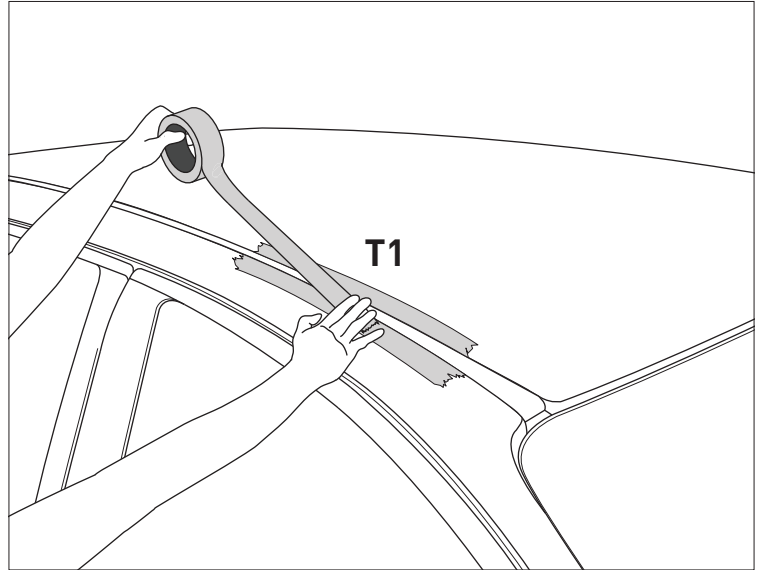
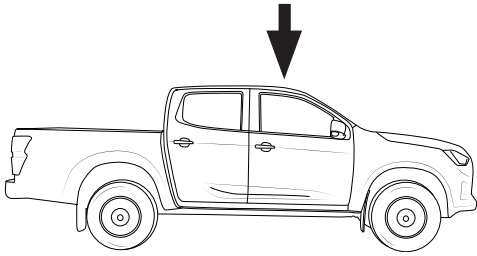

**2** Repeat to opposite side of vehicle

• FOR BT-50 & D-MAX **GEN 3**

Measure from end of rear ditch.  
Continue to step **3**

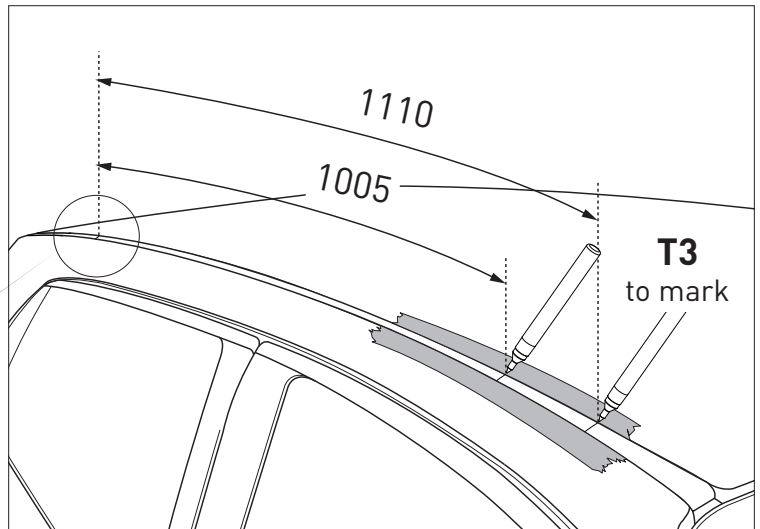
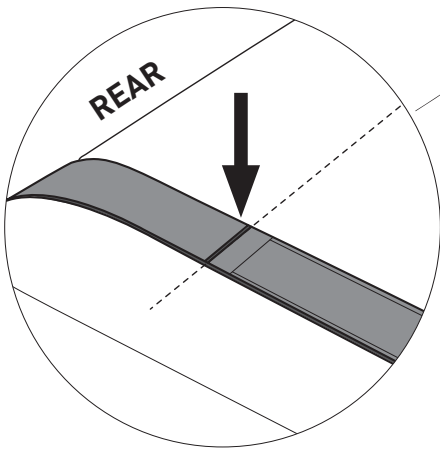

• FOR COLORADO & D-MAX **GEN 2**

Measure from windscreen rubber  
Continue to step **3**

NOTE:  
Hook tape measure into windscreen rubber

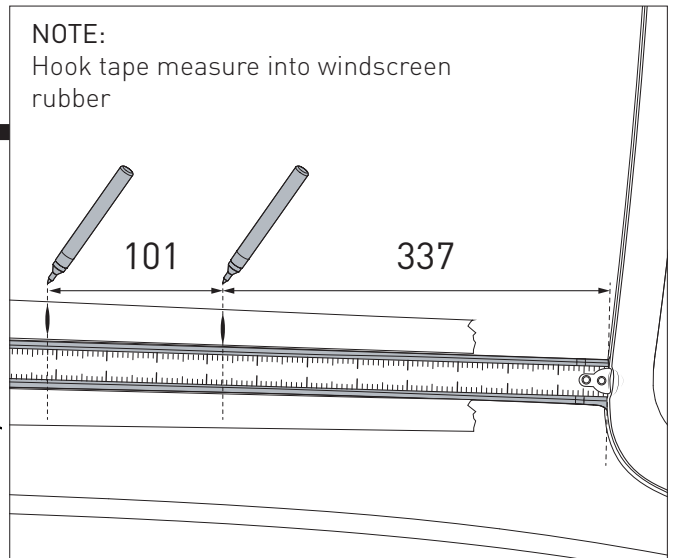
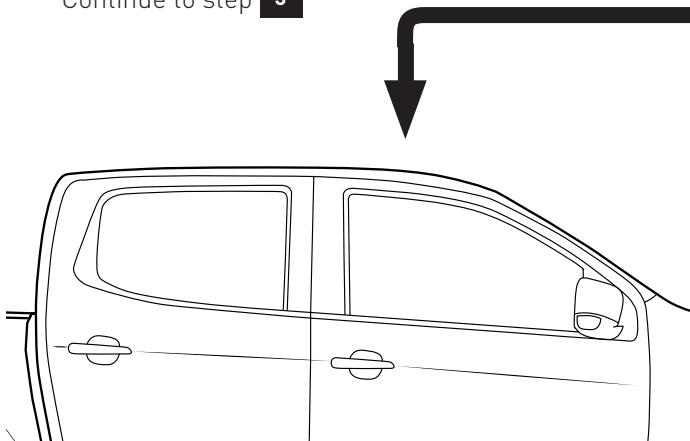

**3** Firmly indent the two measured marks on the entire width of the ditch rubber steel reinforcement strip at the front of the vehicle.

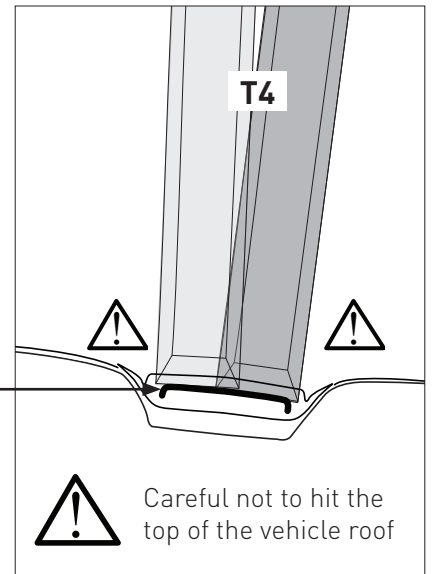
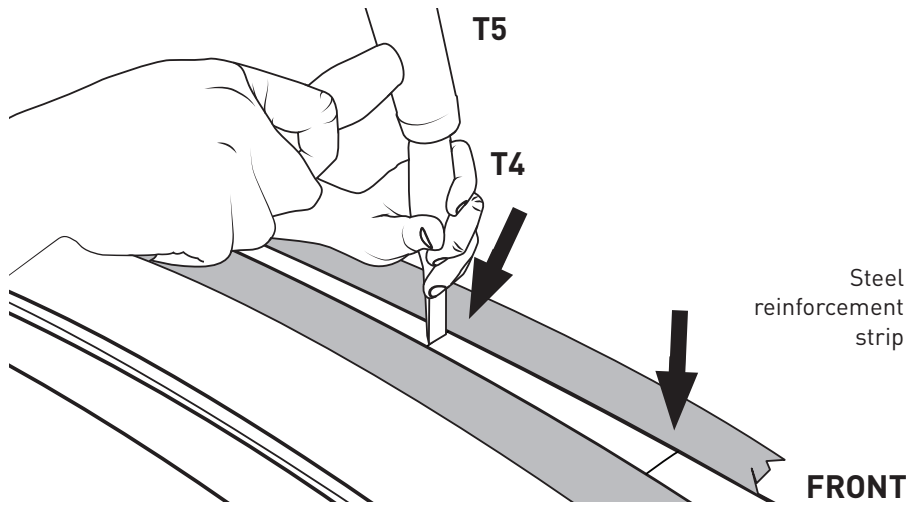

**4** Break through the metal strip between the two measured marks made in Step 2

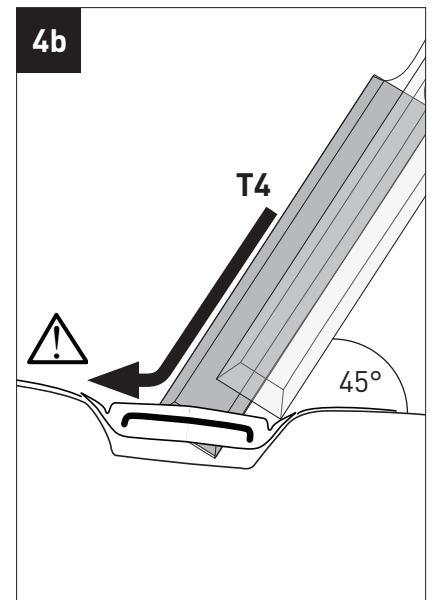
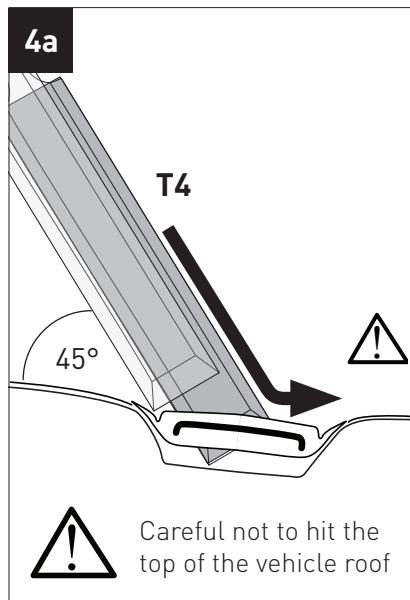
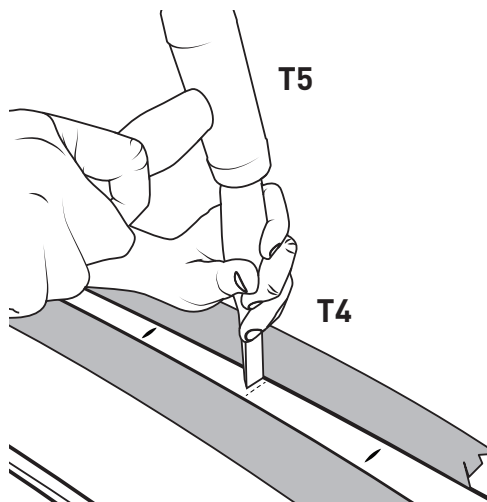

**5** If necessary, use a knife to cut through any rubber remaining on either side of the metal strip.

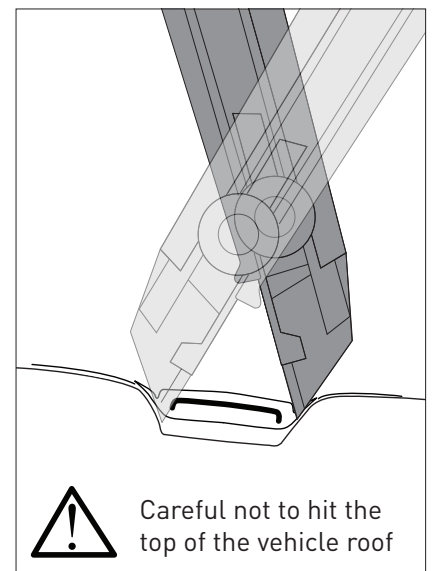
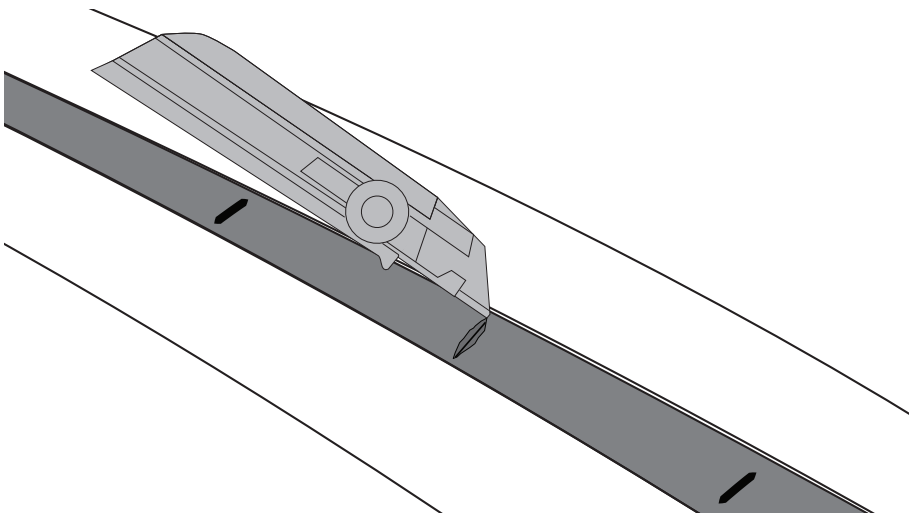

**6** Wedge a flat head screwdriver underneath the cut in the ditch rubber and lift to separate

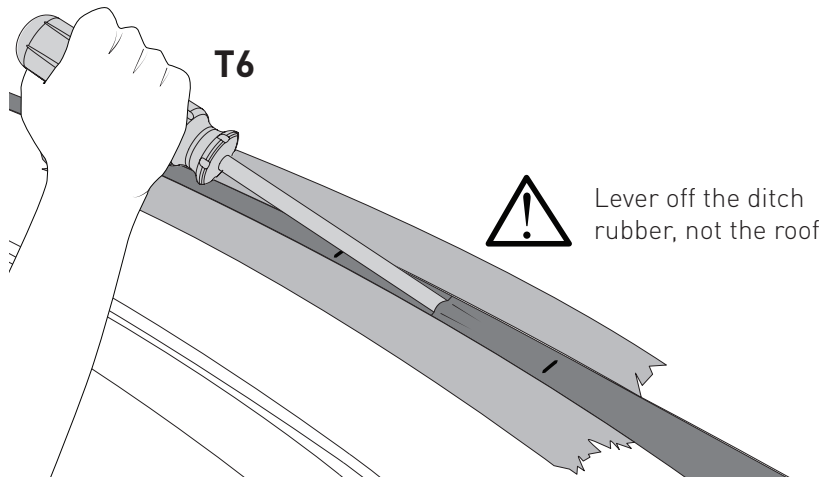

**6a** Careful not to hit the bottom of the roof ditch

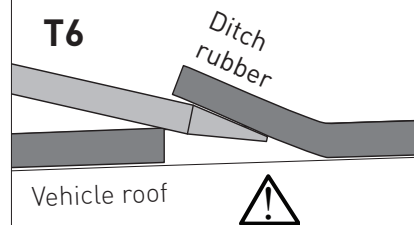

**7** Work the strip back & forth to snap off then cut through ditch rubber with a knife. Repeat to ditch rubber B.

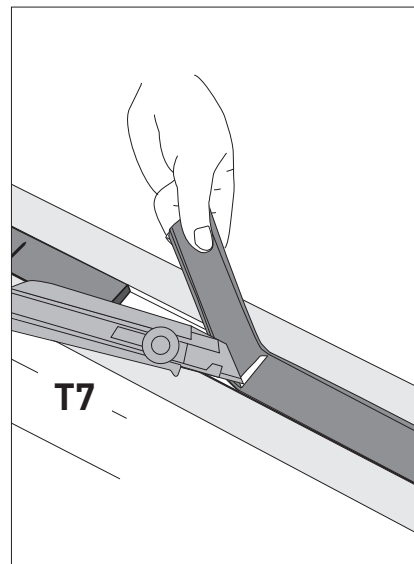
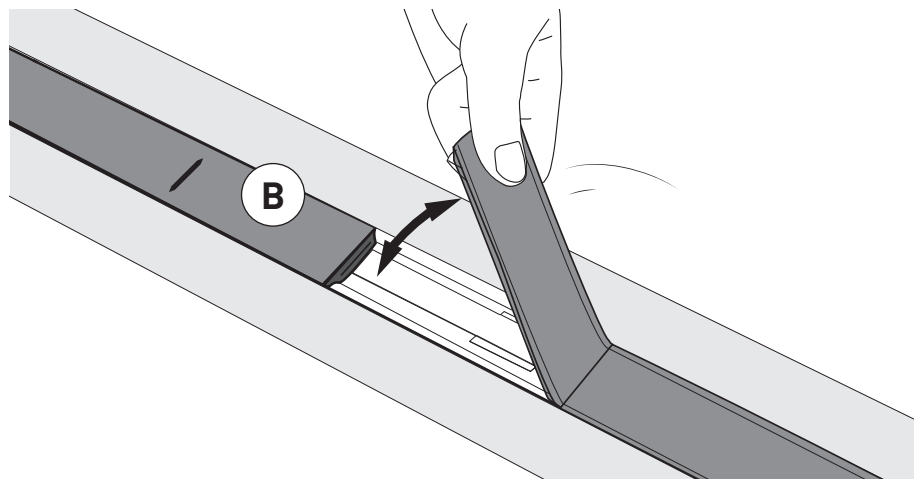

**8** • FOR BT-50 & D-MAX **GEN 3**

Follow this step then continue to step **10**

• FOR COLORADO & D-MAX **GEN 2**

Follow this step then continue to step **9**

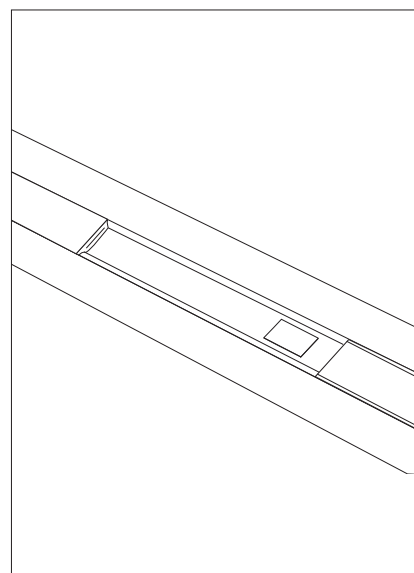
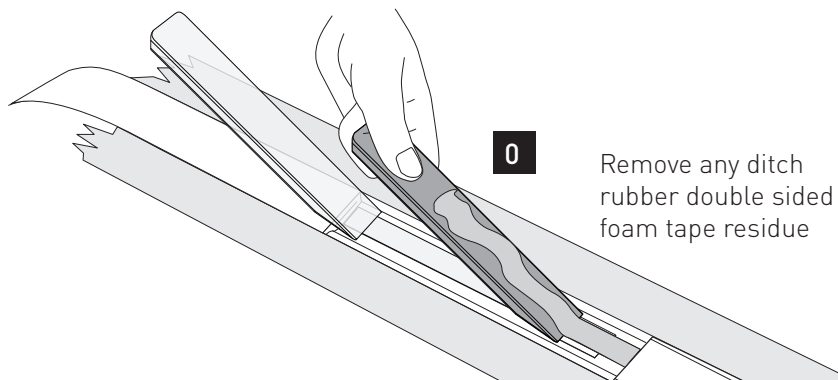

**9** • FOR COLORADO & D-MAX **GEN 2 ONLY**

Inspect area where roof pads will sit. Remove any excessive sealant as it may prevent the roof pads from sitting evenly, and effectively sealing against water leaks.

Continue to step **10**

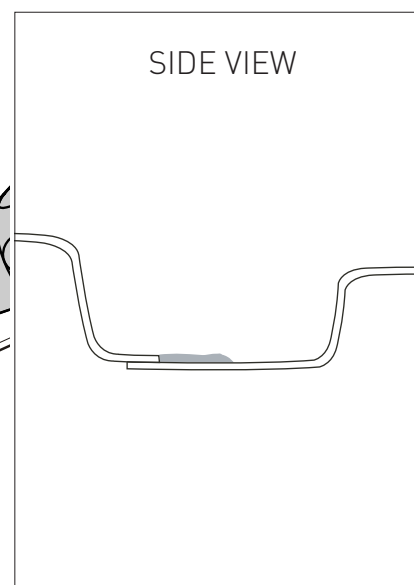
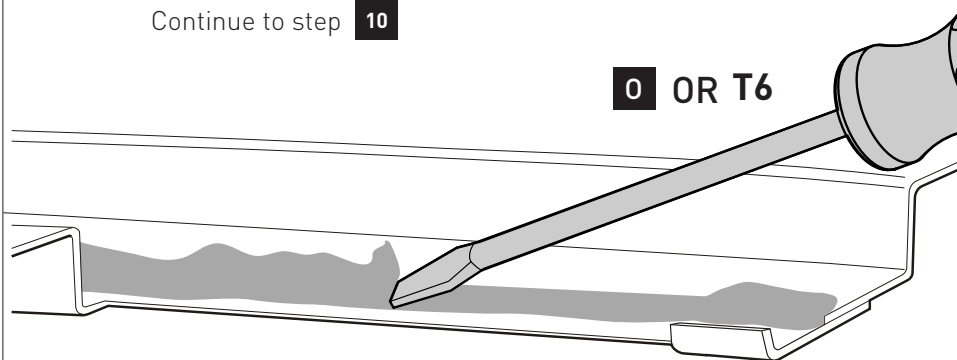

**10**

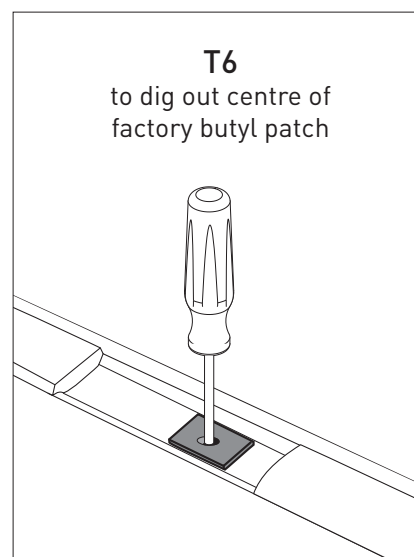
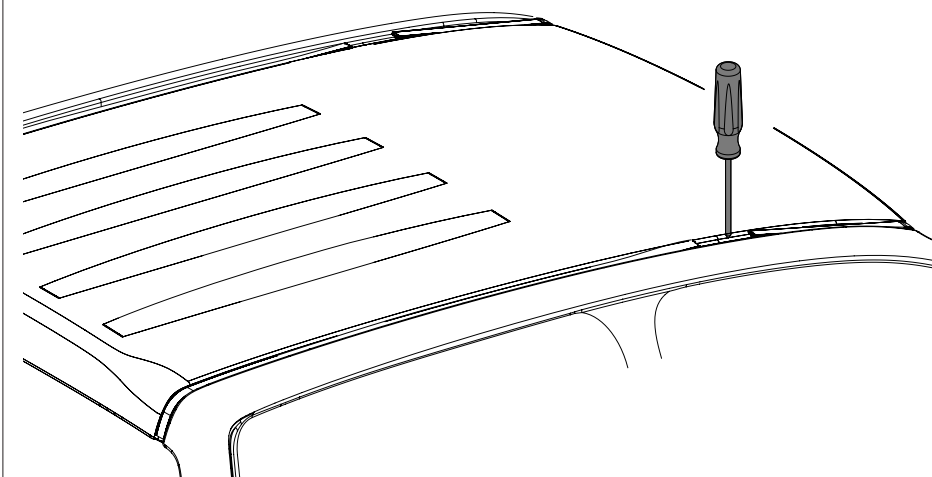

**11** Test exposed threads with M8 Screws. Remove any material causing binding. Repeat steps **3 - 11** to opposite side of vehicle.

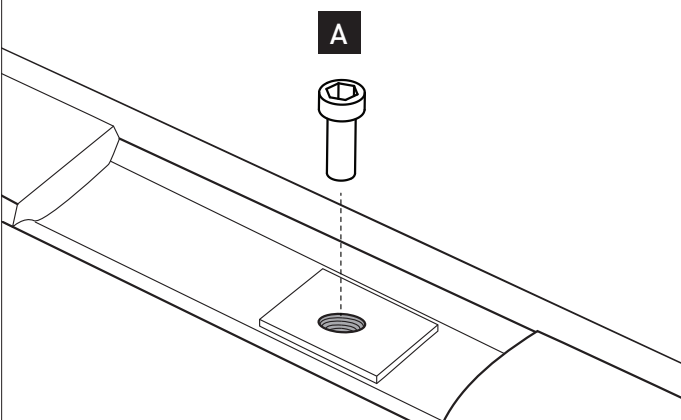

**12** Apply cold galvanising paint to any marks in the vehicle paint from the chisel. Repeat to opposite side of vehicle

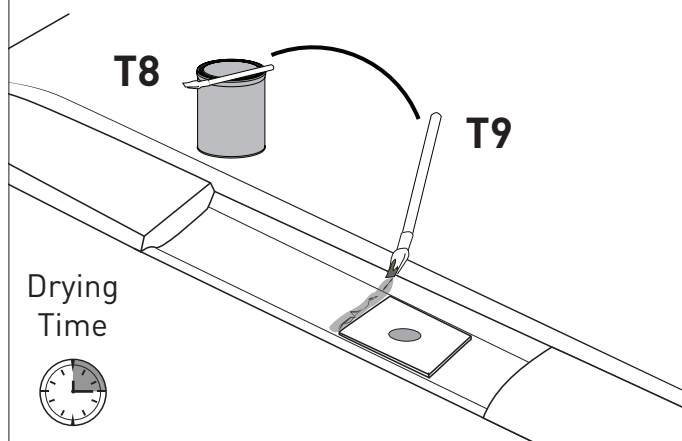



13

Repeat to opposite side of vehicle

- FOR BT-50 & D-MAX **GEN 3**

Continue to step **15**

- FOR COLORADO & D-MAX **GEN 2**

Continue to step **14**

13a

E

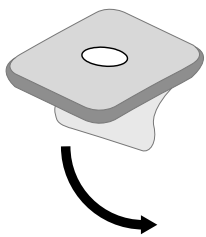

13b

E

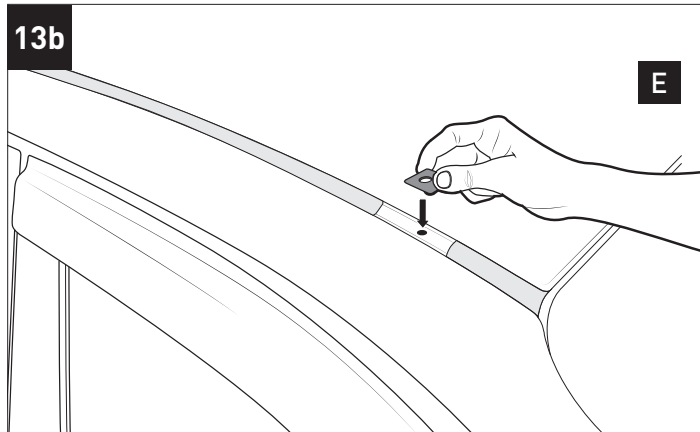

13c

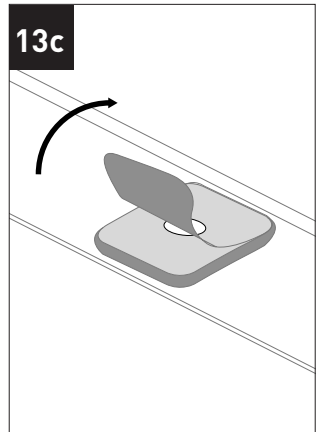

14

- FOR COLORADO & D-MAX **GEN 2**

Apply sealant over the full lengths of the exposed joint

T10

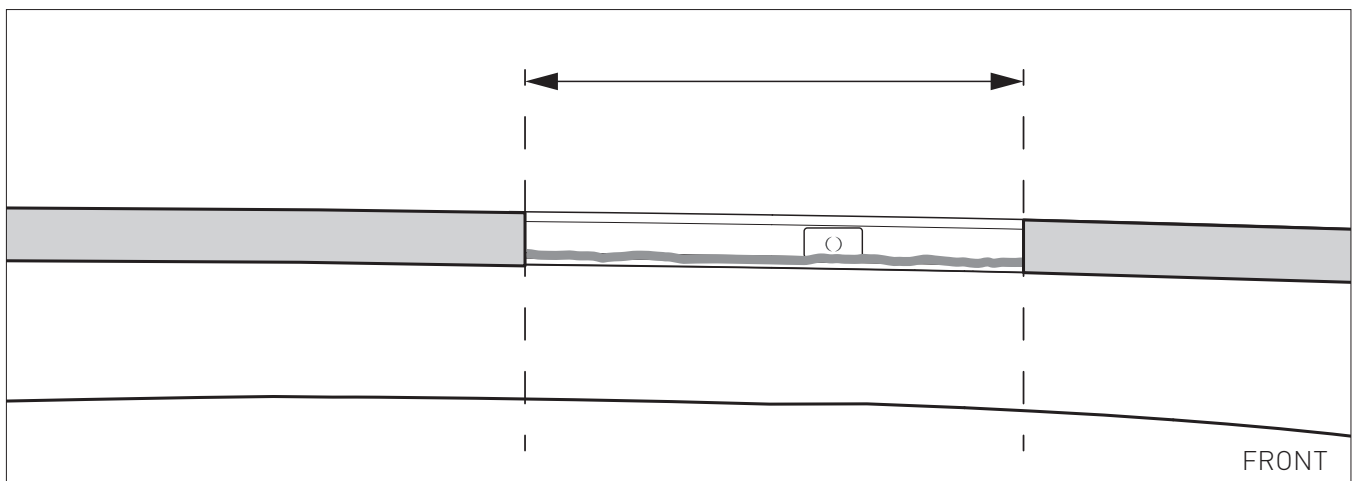
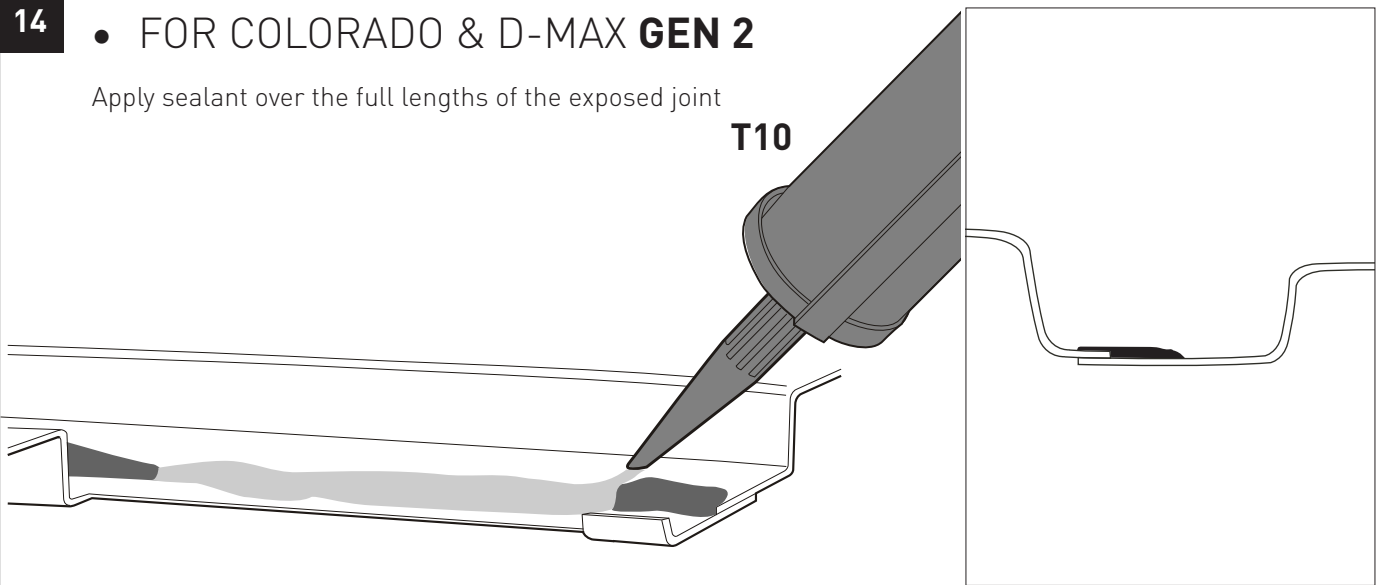

**15** Refer to Step **18** to assemble pads to skirts ensuring arrows are facing the same direction.

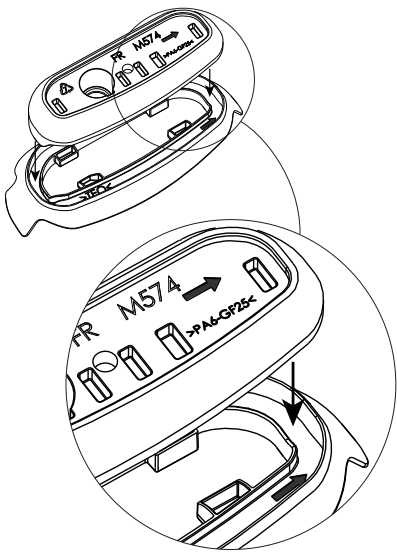

**16**

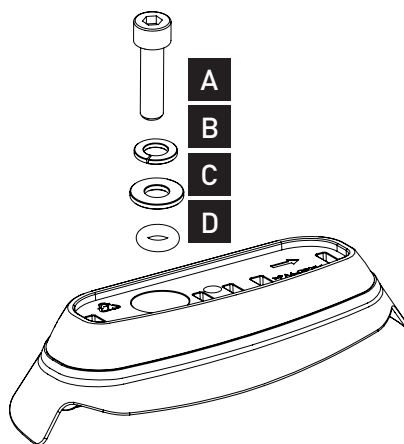

**17** Arrows to face the front of the vehicle

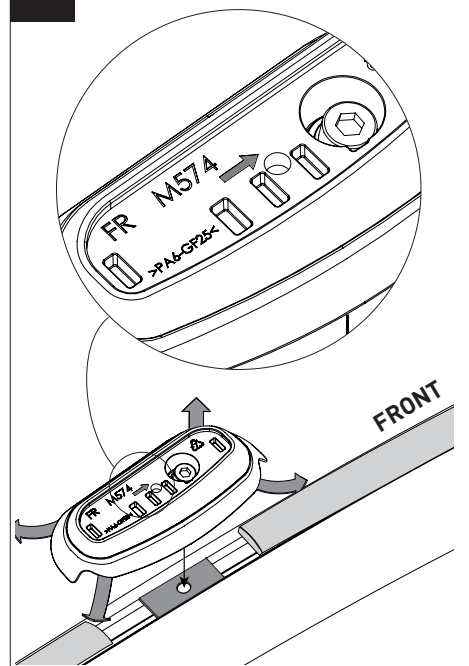

**18**

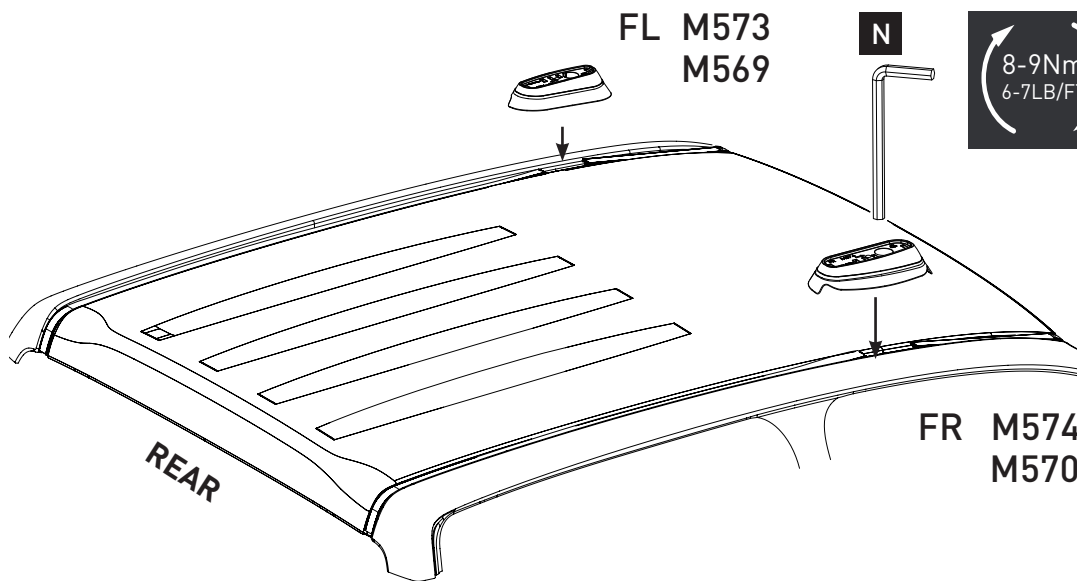

**19**



When not in use, attach pad cover plates as removing base pads will compromise sealing of roof attachment

