

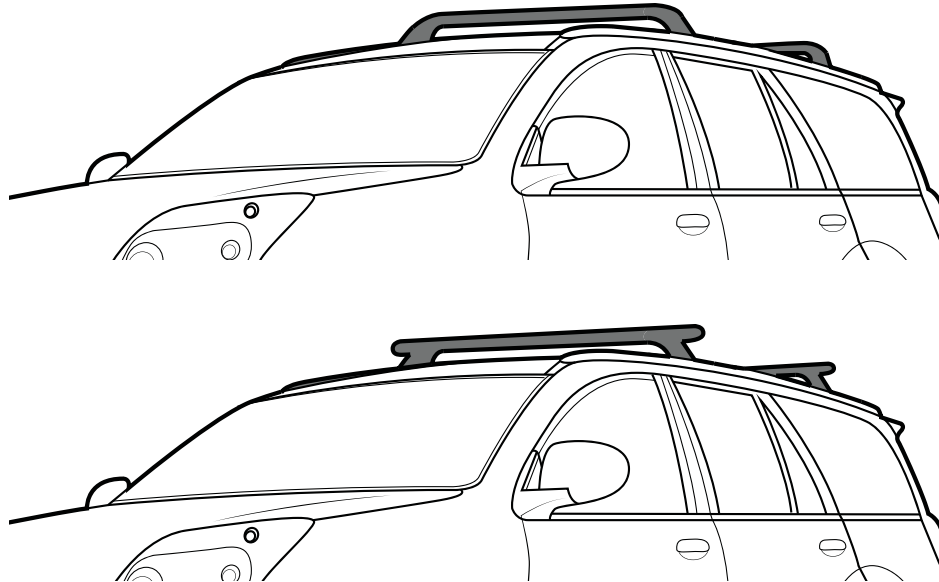

# RHINO-RACK

## RCP26-BK Pad Kit Great Wall X200/X240 MY2011>

**Important:** Please read these instructions carefully prior to installation.  
Please refer to your fitting instruction to ensure that the Roof Rack System is installed in the correct location.  
Check the contents of kit before commencing fitment and report any discrepancies.  
Place these instructions in the vehicle's glove box after installation is complete.



**Note:** Crossbars and legs sold as separate.

**Maximum roof load: 75kg**

1.  Check Part No./Kit is correct
2.  Read through instruction before installing
3.  Fit roof rack accessory
4.  Check and recheck all fasteners are secure

**Refer to vehicle manufacturers handbook for maximum roof loading. Always use lower of the two figures.**

**Recommendations: Note: Be sure to check Rhino-Rack website to see if you have the latest version of instructions before beginning installation.**

It is essential that all bolt connections be checked after driving a short distance when you first install your crossbars. Bolt connections should be checked again at regular intervals (probably once a week is enough, depending on road conditions, usage, loads and distances travelled). You should also check the crossbars each time they are refitted. Make sure to fasten your load securely. Please ensure that all loads are evenly distributed and that the centre of gravity is kept as low as possible.

**Crossbars must be removed when putting vehicle through an automatic car wash.**

**Carrying Loads:** Use only non-stretch fastening ropes or straps to secure your load.

**Caution:** The handling characteristics of the vehicle change when you transport a load on the roof. For safety reasons we recommend you exercise extreme care when transporting wind-resistant loads. Special consideration must be taken into account when cornering and braking.

#### Load Ratings:

Maximum permissible load is 75kg (165lbs) for two crossbars including the weight of the crossbars, 5kg (11lbs). When crossbars are to be used in off-road conditions, please build a safety factor of 1.5 into this load limit for off-road use, two crossbars = **50kg 110lbs**). Although the crossbars are tested and approved to AS1235-2000, off-road conditions can be much more rigorous. However, increasing the number of crossbars does not increase the vehicles maximum permissible roof loading.

#### Note for Dealers and Fitters:

It is your responsibility to ensure instructions are given to the end user or client.

Rhino-Rack  
3 Pike Street, Rydalmere,  
NSW 2116, Australia.  
(Ph) (02) 9638 4744  
(Fax) (02) 9638 4822

Document No: R1333  
Prepared By: Scott Murray  
Authorised By: Chris Murty

Fit Time: 30min  
Issue No: 01  
Issue Date: 12/04/2017

These instructions remain the property of Rhino-Rack Australia Pty. Ltd. and may not be used or changed for any other purpose than intended.



# Great Wall X200/X240 (RCP26-BK)

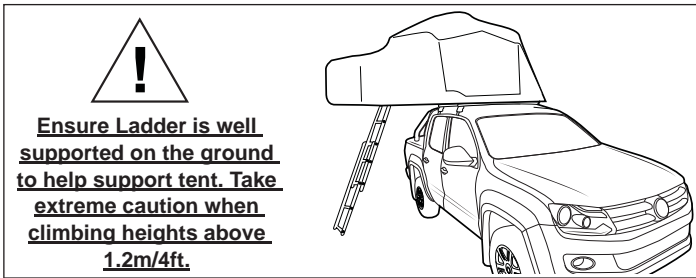
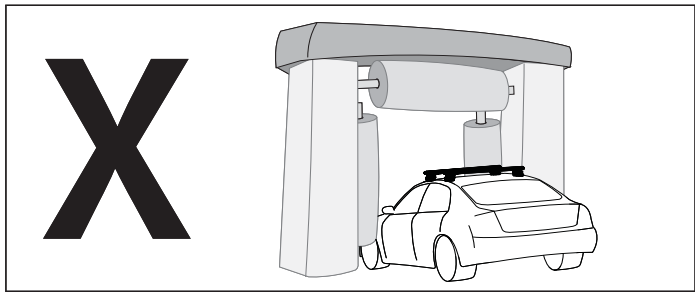
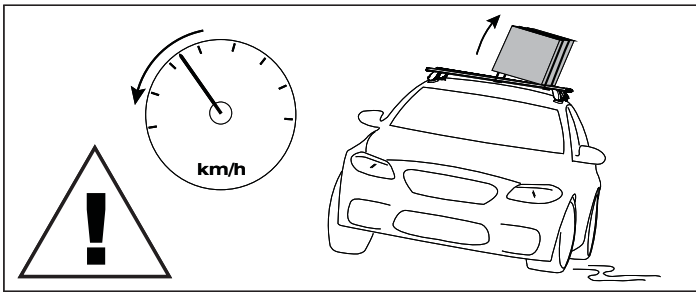
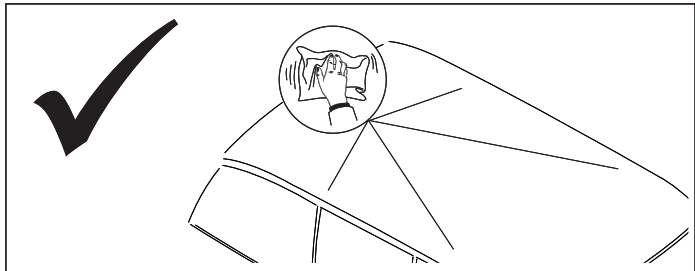
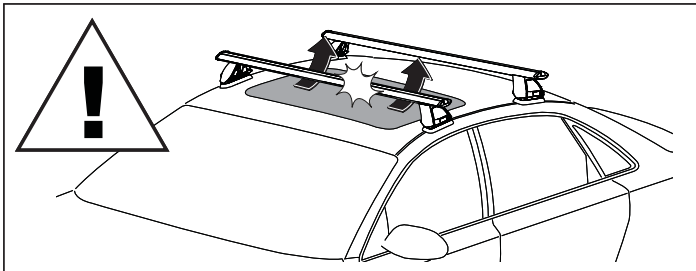
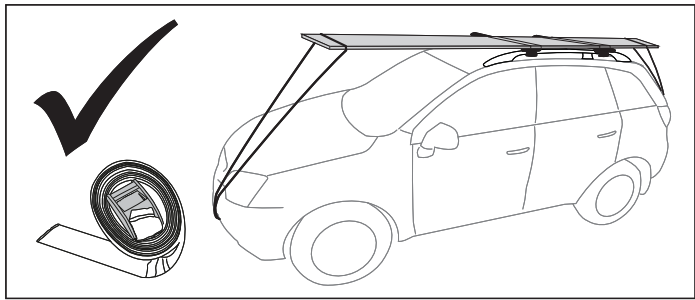
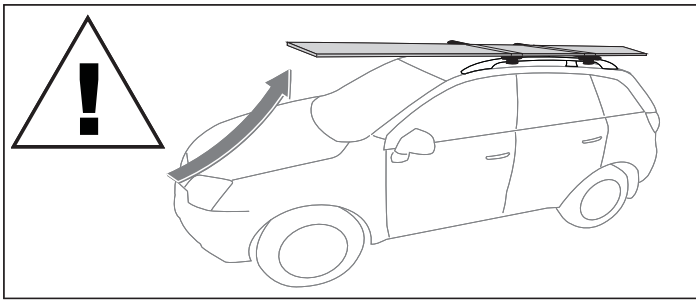

**Ensure Ladder is well supported on the ground to help support tent. Take extreme caution when climbing heights above 1.2m/4ft.**

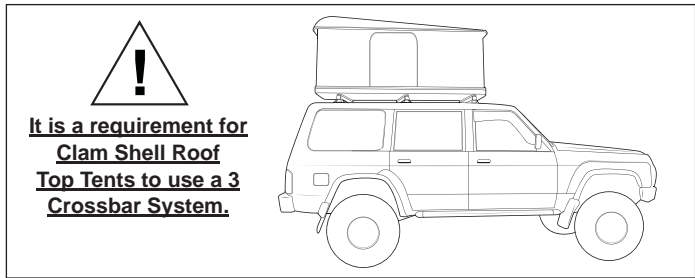

**It is a requirement for Clam Shell Roof Top Tents to use a 3 Crossbar System.**

When these roof racks are to be used on a vehicle that is driven off sealed roads, the maximum roof rack load rating should be **divided by 1.5**. Do not forget to subtract 5kg from your maximum carrying capacity due to the weight of the crossbars and legs.

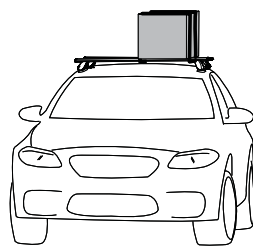

**75kg/165lbs**  
load rating  
(Urban road)

**50kg/110lbs**  
load rating  
(Off road  
- 75kg / 1.5)

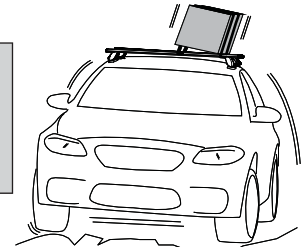

## WARNING! Important Load Carrying Instructions

With utility vehicles, the cabin and the canopy move independently. Roof racks and vehicle can be damaged if the item transported is rigidly fixed at points on both the cabin and canopy. Instead, rigidly fix to either the cabin roof racks or the canopy roof racks.

**X**  
NO

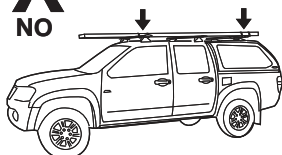

**✓**  
YES

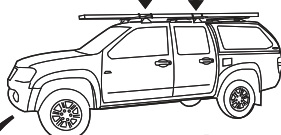

**✓**  
YES

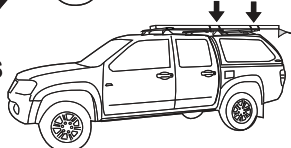

Paddle/ Surfboards should be fixed to the front of the vehicle.

**✓**  
YES

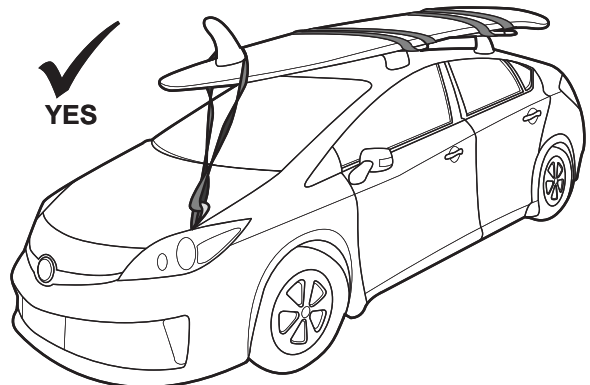



# Great Wall X200/X240 (RCP26-BK)

## Parts List

Item	Component Name	Qty	Part No.
1	M8 x 45mm Socket Cap Screw	8	B187
2	M8 Spring Washer	8	W019
3	Bracket	4	CA1055
4	M6 x 25mm Hex Setscrew	4	B001
5	M6 Spring Washer	4	W004
6	M6 x 16mm Flat Washer	4	W031
7	Cover Plate	4	M126
8	6mm Allen Key	1	H009
9	5mm Allen Key	1	H021
10	M6 Washer (used on cover plate)	4	W003
11	Fitting Instructions	1	R1333

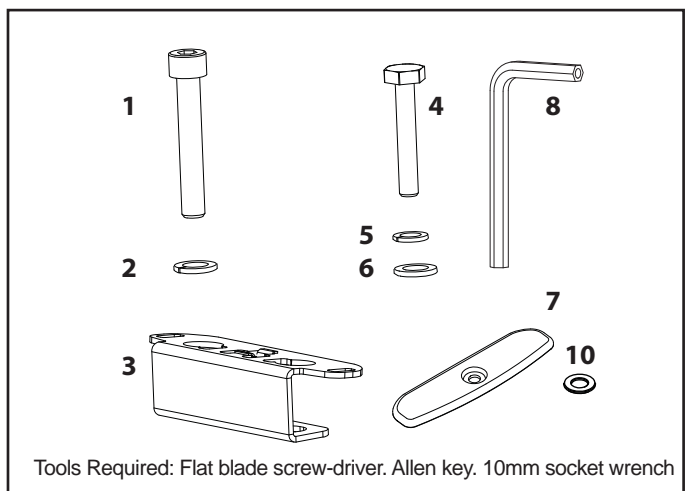

## Instructions

