

START HERE!

READ ME FIRST

Don't be a hero and muscle through this installation without reading these fitting instructions first! Improper installation of this gear may void certain aspects of your warranty.

Before you begin, take a moment and open all your Front Runner rack kit boxes and gather the assembly instructions for the various components.

A complete kit will contain:

1. A Front Runner Mounting System specific to your vehicle
2. A Front Runner Rack Tray or Load Bar Slats

This document will guide you through the assembly of the mounting system and assist you in fitting the roof rack tray or load bars to your specific vehicle.

Please refer to the next page for a list of all the components, quantities and tools required.

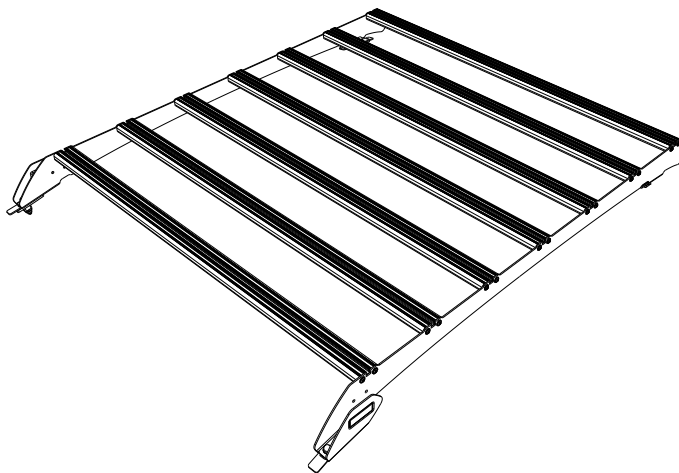

IMPORTANT WARNING!

IT IS CRITICAL THAT ALL FRONT RUNNER PRODUCTS BE PROPERLY AND SECURELY ASSEMBLED AND ATTACHED TO YOUR VEHICLE. IMPROPER ATTACHMENT COULD RESULT IN AN AUTOMOBILE ACCIDENT, AND COULD CAUSE SERIOUS BODILY INJURY OR DEATH. YOU ARE RESPONSIBLE FOR ASSEMBLING AND SECURING ALL FRONT RUNNER PRODUCTS TO YOUR VEHICLE, CHECKING THE ATTACHMENTS PRIOR TO USE, AND PERIODICALLY INSPECTING THE PRODUCTS FOR ADJUSTMENT, WEAR AND DAMAGE. THEREFORE, YOU MUST READ AND UNDERSTAND ALL OF THE INSTRUCTIONS AND PRECAUTIONS SUPPLIED WITH YOUR FRONT RUNNER PRODUCT PRIOR TO INSTALLATION OR USE. IF YOU DO NOT UNDERSTAND ALL OF THE INSTRUCTIONS AND CAUTIONS, OR IF YOU HAVE NO MECHANICAL EXPERIENCE AND ARE NOT THOROUGHLY FAMILIAR WITH THE INSTALLATION PROCEDURES, YOU SHOULD HAVE THE PRODUCT INSTALLED BY A PROFESSIONAL INSTALLER OR OTHER QUALIFIED PERSONNEL.

NOTE: Front Runner will not be responsible for any damage caused by the failure to install the product according to these instructions.

Please call us if you have any questions about the installation of this product.



1 GET ORGANIZED

IN THE BOX

1	2 X	Foot Rail 1LH + 1RH
2	2 X	Wing Plate 1 LH + 1 RH
3	7 X	SlimSport Slat (1160mm Long)
4	28 X	M6 x 25 Thread Forming Screw
5	4 X	M8 x 40 Hex Head Flange Bolt
6	4 X	M8 Nut Cap
7	2 X	Front Spacer - 10mm
8	2 X	Rear Spacer - 10mm
9	4 X	M8 x 19 x 2 Flat Washer
10	4 X	M8 Nyloc Nut
11	4 X	Bottom Spacer (Non Wildtrak versions)

TOOLS NEEDED

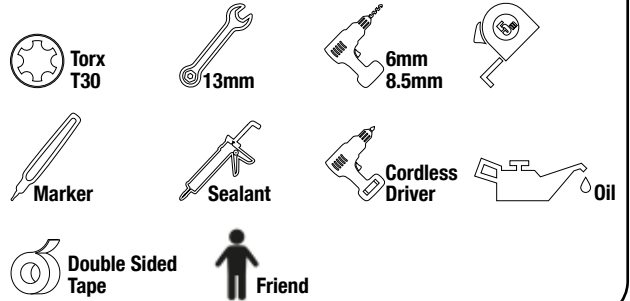
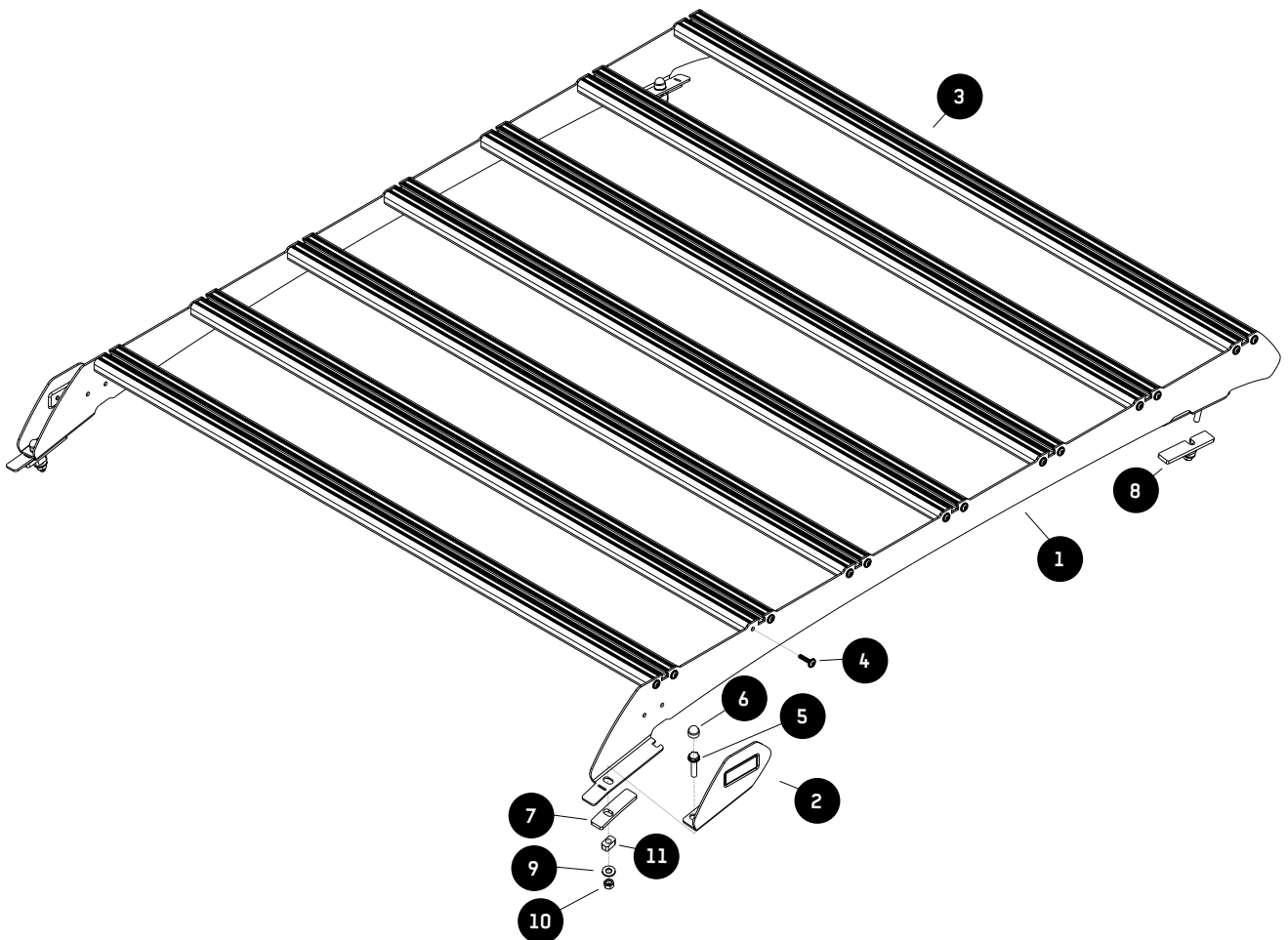

FIGURE 1.1

Tightening Torque:
M8 : 15-20Nm / 11.06 ft lb - 14.75 ft lb



2.1



Drop the vehicle's roof lining.



Look online for videos to assist.

2.2

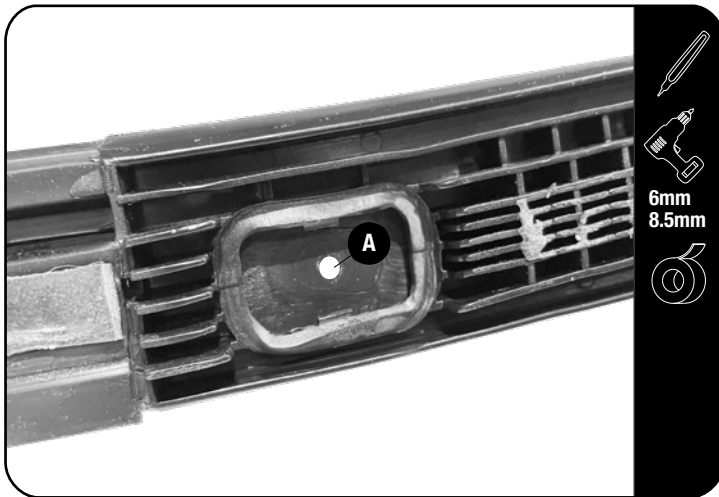

6mm
8.5mm

Models without factory Roof Rails.



Remove the Ditch Mold from the vehicles roof. Remove the Nut insert from the plastic trim and place the Bottom Spacer (Item 11) into the opening and mark the center of the hole (A). Drill a 6mm Pilot hole and open it to a 8.5mm Hole. Refit the Ditch Trim with the Bottom Spacer in place

Models with factory Roof Rails.

Remove the top factory fitted roof rails.

2.3

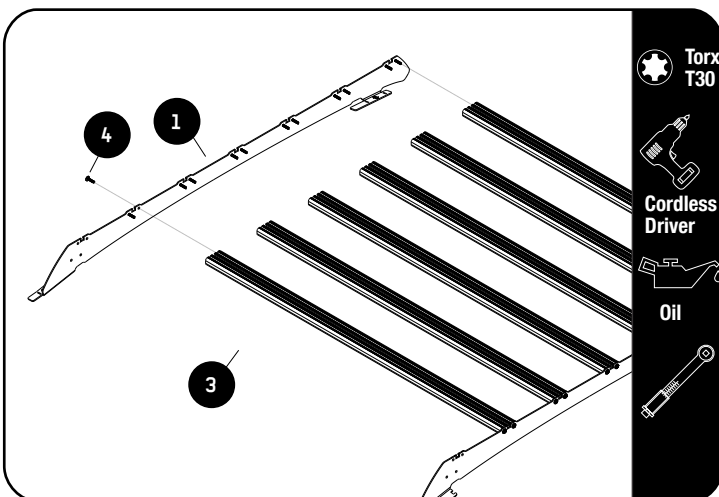

Torx
T30

Cordless
Driver

Oil



Assemble the Footrails (Item1) to the six rear slats (Item 3) (leave the first slat unassembled for now) using M6 x 25 Thread Forming Screws (Item 4).



NOTE: Do not fit the front slat yet.



Apply a little oil on screw threads before inserting. Note these are thread forming screws.



Tightening Torque 8-10Nm / 5.9 ft lb - 7.38 ft lb. Take care when using a cordless driver.

2 FIT AND SECURE

2.4

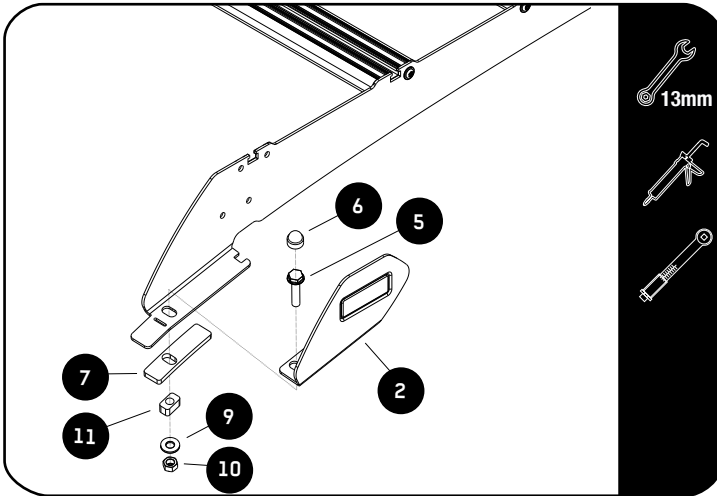

 Clean the area around the holes in the vehicle's roof. Place some sealant around each hole in the vehicle's roof.

Place some silicone in the cut outs of the spacers (Item 7, 8 & 11).

Refer to RRAC250 or RRAC251 before fully tightening Item 2 and fitment of the first slat.

Place a bead of silicone along the threads of the M8 x 40 Hex Head Flange Bolts and secure the rack using M8 x 40 Hex Head Flange Bolts, M8 x 19 x 2 Flat Washers, Dimple Plates & Nyloc Nuts (Items 2, 5, 9 & 10).

Have a friend help hold the Nyloc Nuts and M8 x 19x 2 Flat Washers in position against the roof. Fully tighten.

Place M8 nut caps (Item 6) over all hex bolts.

3 COMPLETION

3.1

Congratulations! You did it. Take a step back and admire your work!







4 INSTALL OTHER VEHICLE AND RACK ACCESSORIES

Now's the time to visit your favorite Front Runner dealer in person or online.

IMPORTANT!

FRONT RUNNER RACK KITS OFTEN HAVE A HIGHER LOAD RATING THAN THE VEHICLES THEY ARE MOUNTED TO. PLEASE REFER TO YOUR SPECIFIC VEHICLE MANUFACTURER FOR A RECOMMENDED ROOF RATING. FRONT RUNNER CANNOT BE RESPONSIBLE FOR IMPROPER LOADING BEYOND THE VEHICLE MANUFACTURER'S STATED LOAD CAPACITY.

Be sure to tag us. We love to see our gear in action! #FrontRunnerOutfitters #BornToRoam

Share your adventures on:    

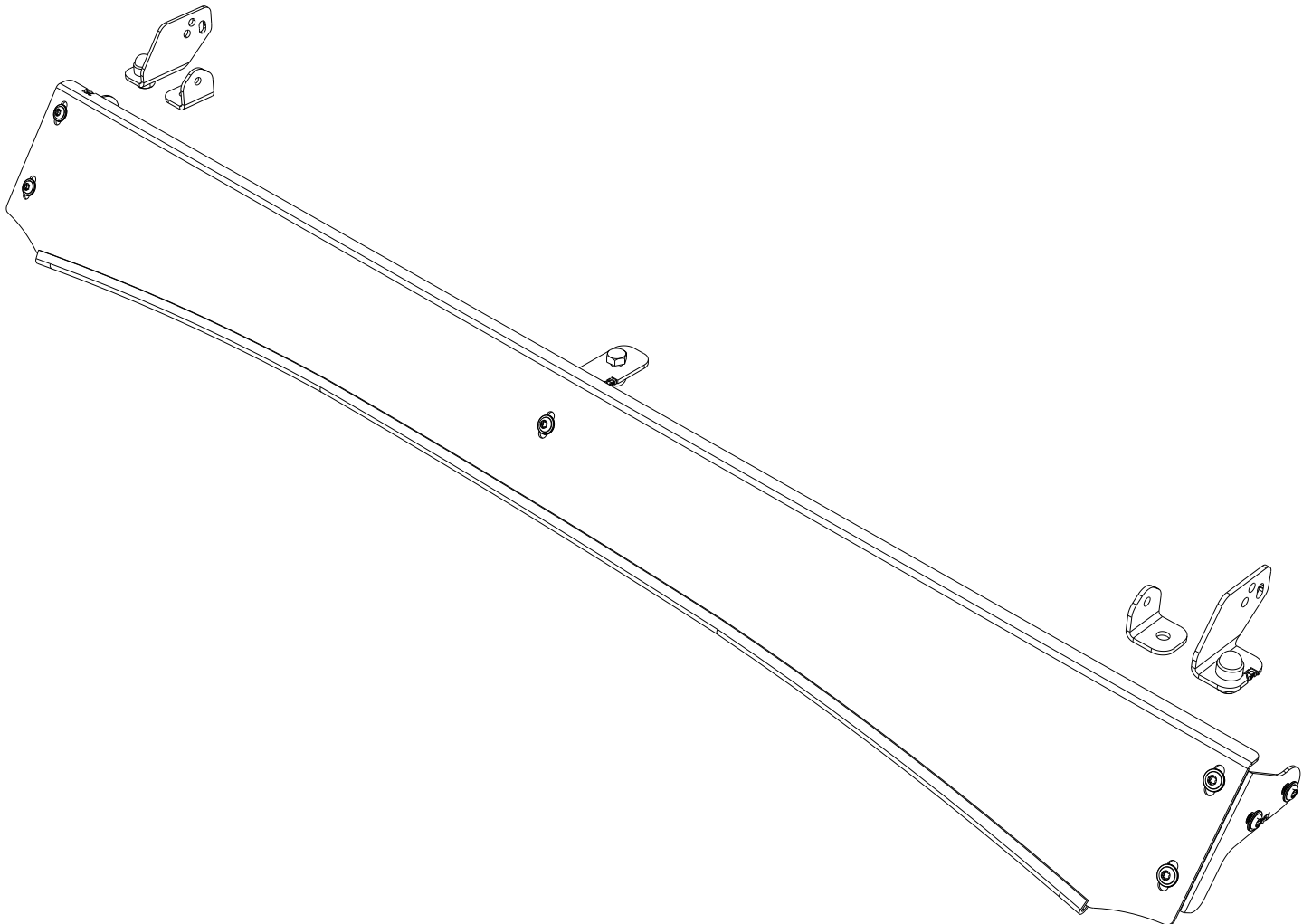

READ ME !

Thank you for purchasing a Front Runner Ford Ranger T6.2 Double Cab (2022 - Current) Slimsport Windfairing.
Before you start, take a moment to familiarize yourself with the Fitting Instructions and the included components.
Refer to Page 2 for a list of all the components, quantities and tools required.

IMPORTANT WARNING!

IT IS CRITICAL THAT ALL FRONT RUNNER PRODUCTS BE PROPERLY AND SECURELY ASSEMBLED AND ATTACHED TO YOUR VEHICLE. IMPROPER ATTACHMENT COULD RESULT IN AN AUTOMOBILE ACCIDENT, AND COULD CAUSE SERIOUS BODILY INJURY OR DEATH. YOU ARE RESPONSIBLE FOR ASSEMBLING AND SECURING ALL FRONT RUNNER PRODUCTS TO YOUR VEHICLE, CHECKING THE ATTACHMENTS PRIOR TO USE, AND PERIODICALLY INSPECTING THE PRODUCTS FOR ADJUSTMENT, WEAR AND DAMAGE. THEREFORE, YOU MUST READ AND UNDERSTAND ALL OF THE INSTRUCTIONS AND PRECAUTIONS SUPPLIED WITH YOUR FRONT RUNNER PRODUCT PRIOR TO INSTALLATION OR USE. IF YOU DO NOT UNDERSTAND ALL OF THE INSTRUCTIONS AND CAUTIONS, OR IF YOU HAVE NO MECHANICAL EXPERIENCE AND ARE NOT THOROUGHLY FAMILIAR WITH THE INSTALLATION PROCEDURES, YOU SHOULD HAVE THE PRODUCT INSTALLED BY A PROFESSIONAL INSTALLER OR OTHER QUALIFIED PERSONNEL.

NOTE: Front Runner will not be responsible for any damage caused by the failure to install the product according to these instructions.
Please call us if you have any questions about the installation of this product.



1 GET ORGANIZED

IN THE BOX

1	1 X	Light Bar Wind Fairing
2	2 X	Wind Fairing Side Support (1LH + 1RH)
3	1 X	Wind Fairing Mid Support
4	2 X	Light Bar Bracket 01 (1LH + 1RH)
5	2 X	Light Bar Bracket 02
6	9 X	M6 x 16 Flange Buton Head
7	3 X	M8 x 16 Hex Head Bolt
8	3 X	M8 Nyloc Nut
9	3 X	M8 Nut Cap
10	X	Wind Faring Rubber (1050mm Long)

TOOLS NEEDED

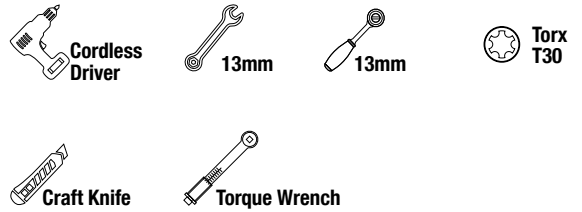
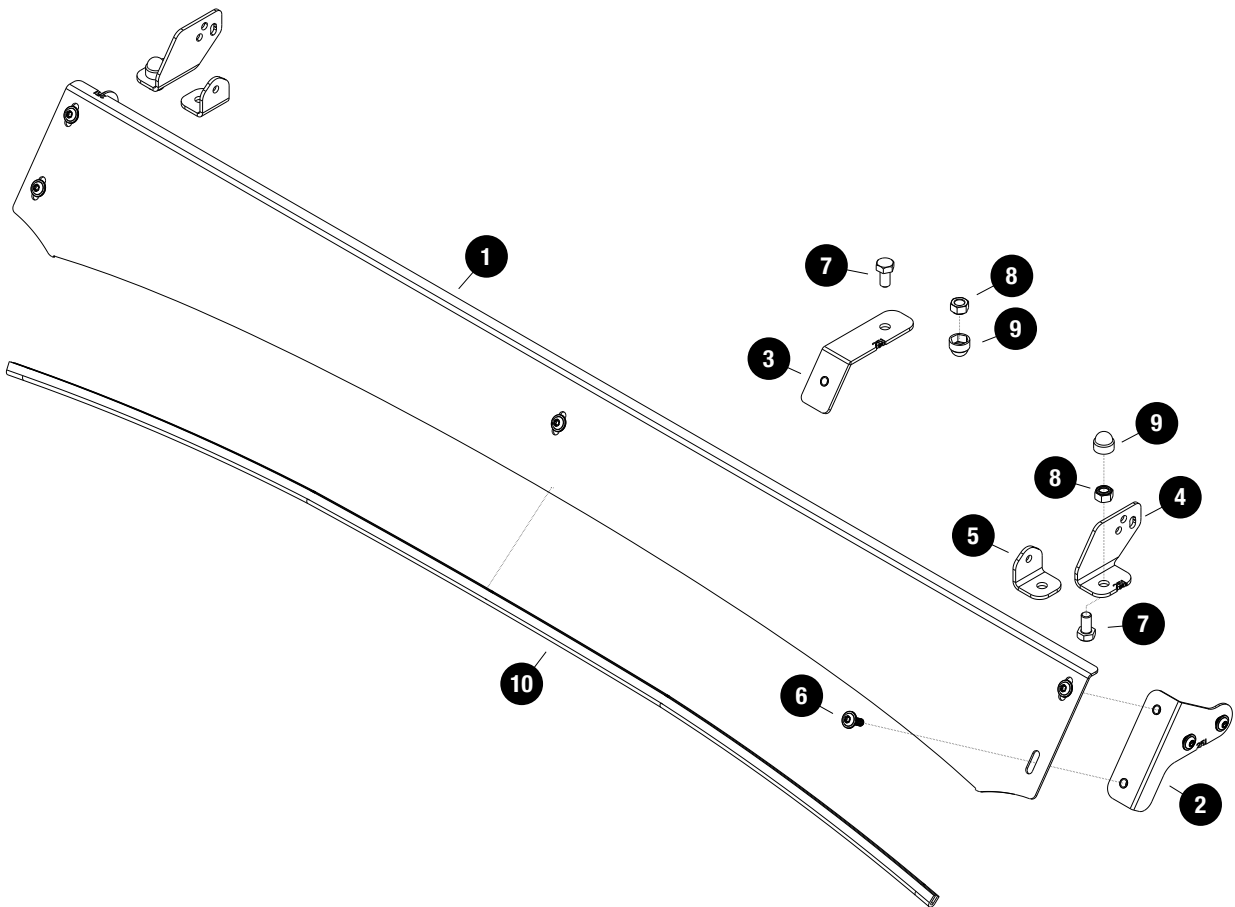

FIGURE 1.1



2

FIT AND SECURE

2.1

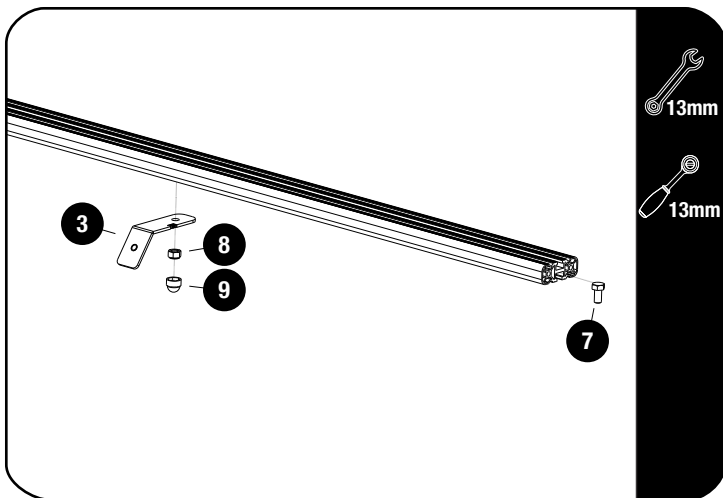

Slide one M8 x 16 Hex Head Bolt (Item 7) into the T-slot of the front slat. Center the mid support bracket (Item 3) in the middle of the slat and secure using M8 Nyloc Nut (Item 8). Loosly assembly.

Place a M8 Nut Cap (Item 9) over the Nyloc Nut.

2.2

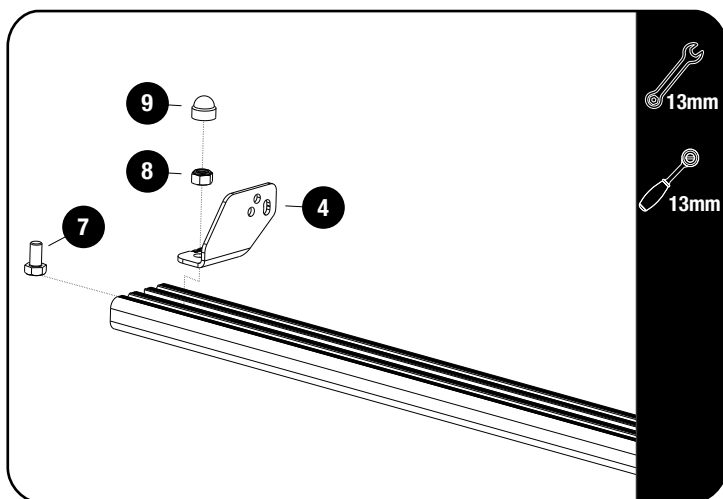

Fit the Light Bar Bracket 01 LH / RH (Item 4) for for the 40" Light Bar, using M8 x 16 Hex Bolt & M8 Nyloc Nut (Items 7 & 9). Fit the light bar and center it on the slat before fully tightening the brackets.

Place M8 Nut Caps (Item 9) over all Hex Bolts.

2.3

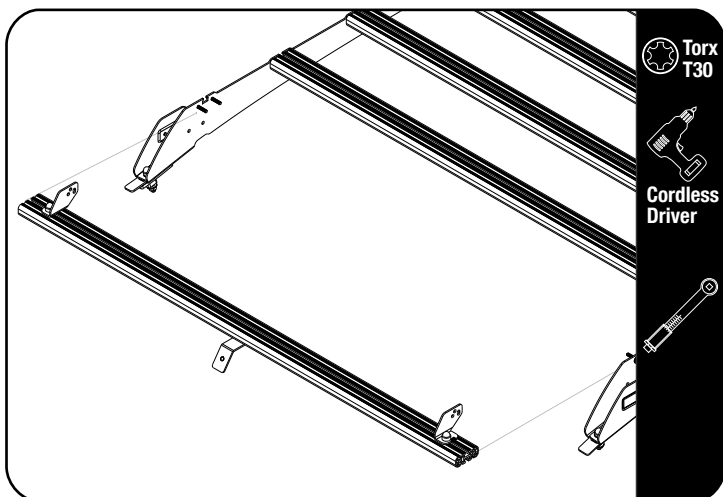

Secure assembly 2.2 to the front two top holes on the foot rails using the fasteners supplied with KSFR005.



**Tightening Torque 8-10Nm /
5.9 ft lb - 7.38 ft lb.**

2

FIT AND SECURE

2.4

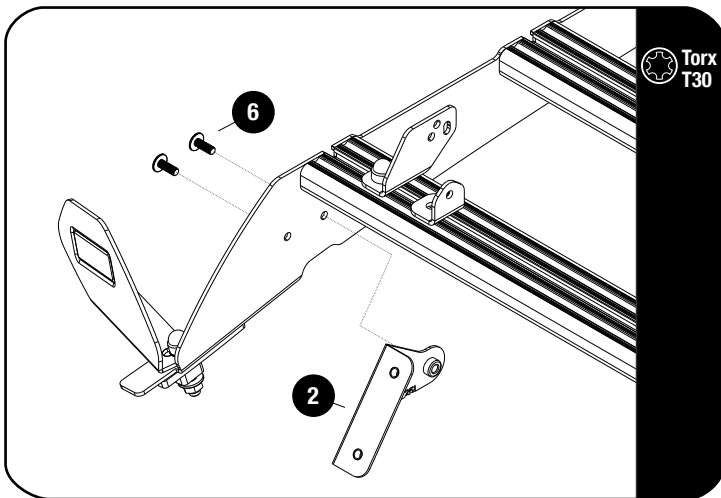

🔄 Swing over the Dimple plate to allow access to tighten the bolts.

Secure the Wind Fairing Side supports LH / RH (Item 2) to the foot rails bottom holes as shown using M6 x 16 Flange Button Heads (Item 6).

2.5

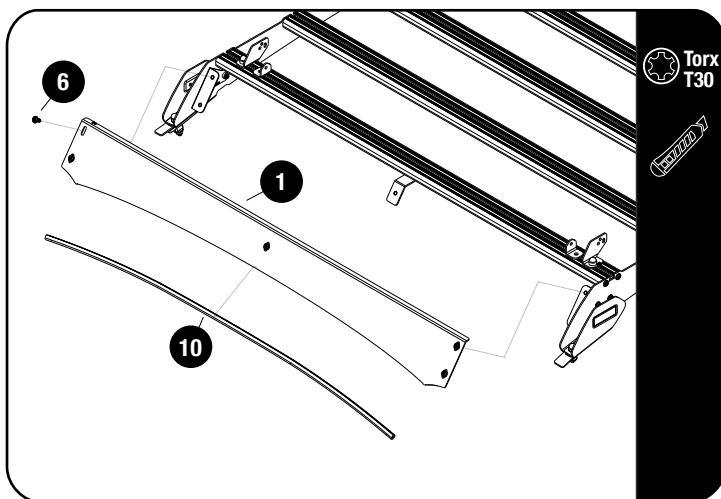

🔄 Fit the Wind Fairing Rubber (Item 10) to the Light Bar Wind Fairing (Item 1). Using the notched section as a guide, trim if needed.

Secure the Light Bar Wind Fairing assembly to the rack assembly, using M6 x 16 Flange Button Heads (Item 6) and fully tighten all fasteners.

Reposition the dimple plates and fully tighten.

3

FINISH





Congratulations! You did it. Take a step back and admire your work!

4

INSTALL OTHER VEHICLE AND RACK ACCESSORIES

Now's the time to visit your favorite Front Runner Dealer in person or online.

Be sure to tag us. We love to see our gear in action! #FrontRunnerOutfitters #BornToRoam

Share your adventures on:    

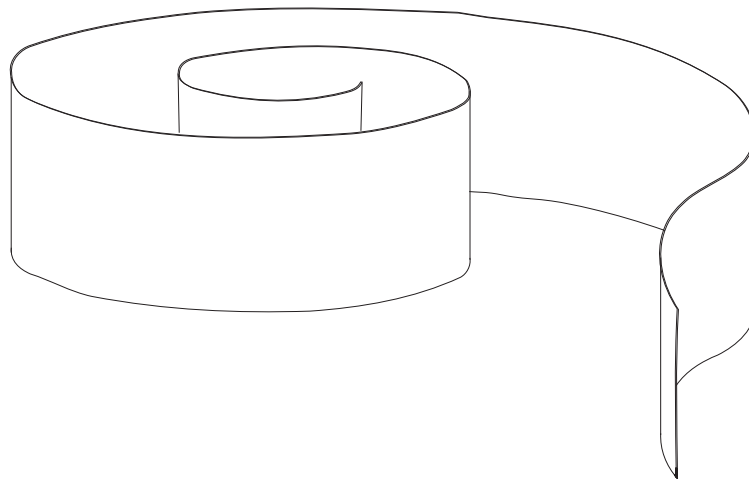
**READ ME !** ⚠

Thank you for purchasing Front Runner Protective strip.

Before you start, take a moment to familiarize yourself with the Fitting Instructions and the components received.

Refer to Page 2 for a list of all the components, quantities and tools required.

IMPORTANT WARNING! ⚠

IT IS CRITICAL THAT ALL FRONT RUNNER PRODUCTS BE PROPERLY AND SECURELY ASSEMBLED AND ATTACHED TO YOUR VEHICLE. IMPROPER ATTACHMENT COULD RESULT IN AN AUTOMOBILE ACCIDENT, AND COULD CAUSE SERIOUS BODILY INJURY OR DEATH. YOU ARE RESPONSIBLE FOR ASSEMBLING AND SECURING ALL FRONT RUNNER PRODUCTS TO YOUR VEHICLE, CHECKING THE ATTACHMENTS PRIOR TO USE, AND PERIODICALLY INSPECTING THE PRODUCTS FOR ADJUSTMENT, WEAR AND DAMAGE. THEREFORE, YOU MUST READ AND UNDERSTAND ALL OF THE INSTRUCTIONS AND PRECAUTIONS SUPPLIED WITH YOUR FRONT RUNNER PRODUCT PRIOR TO INSTALLATION OR USE. IF YOU DO NOT UNDERSTAND ALL OF THE INSTRUCTIONS AND CAUTIONS, OR IF YOU HAVE NO MECHANICAL EXPERIENCE AND ARE NOT THOROUGHLY FAMILIAR WITH THE INSTALLATION PROCEDURES, YOU SHOULD HAVE THE PRODUCT INSTALLED BY A PROFESSIONAL INSTALLER OR OTHER QUALIFIED PERSONNEL.

NOTE: Front Runner will not be responsible for any damage caused by the failure to install the product according to these instructions.

Please call us if you have any questions about the installation of this product.

1 FIT AND SECURE

1.1

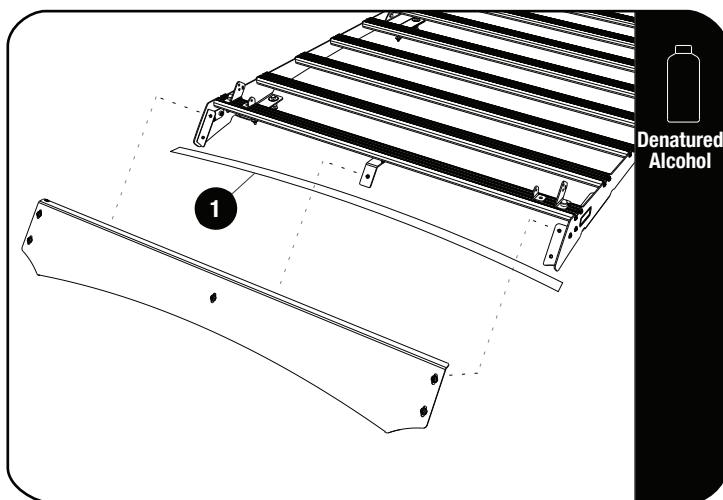

Use the Clear Protective Strip (Item 1) to protect the paint work of the vehicle, where the Rubber Trim may make contact with the roof.

Apply Denatured Alcohol to make sure the roof is clean before applying.

Align the protective strip where the wind fairing rubber strip will be touching the roof.

Remove the backing tape and apply the strip. Use a soft, clean cloth to apply pressure.

Refit the Wind Fairing and fully tighten.

3 WIND FAIRING CARE

Clean dust and debris build-up between the Rubber Trim and Clear Protection Strip at regular intervals.

4 FINISH

Congratulations! You did it. Take a step back and admire your work!

5 INSTALL OTHER VEHICLE AND RACK ACCESSORIES

Now's the time to visit your favorite Front Runner Dealer in person or online.

Be sure to tag us. We love to see our gear in action! #FrontRunnerOutfitters #BornToRoam

Share your adventures on: 