



FRONT CROSSBAR								
Vehicle	Date	Crossbar	Front Pad	M6 Stud length (mm)	M6 Screw length (mm)	Measurement strip length per side	Measurement strip length per side	Measurement Distance (x)
Alfa Romeo Mito 3dr hatch	09 -	1065mm	M473	30	40	168mm	N/A	790mm 31 7/64"
Mazda 2 5dr hatch	15 -	1180mm	M473	30	40	156mm	101mm	880mm 34 41/64"
Mazda CX-3	15 -	1180mm	M473	30	40	167mm	112mm	902mm 35 33/64"
Citroën DS 3 3dr hatch*	10 -	1180mm	M473	30	40	163mm	108mm	894mm 35 13/64"
Mazda CX-5 5dr SUV	17-	1180mm	M473	30	40	196mm	141mm	960mm
Mazda CX-9 5dr SUV	16 -	1260mm	M473	30	40	195mm	82mm	1038mm 40 7/8"

REAR CROSSBAR					
Rear Pad	M6 Stud length (mm)	M6 Screw length (mm)	Measurement strip length per side	Measurement strip length per side	Measurement Distance (x)
M473	30	40	108mm	N/A	670mm 26 3/8"
M473	30	40	133mm	85mm	834mm 32 27/32"
M473	30	40	141mm	86mm	850mm 33 15/32"
M473	30	40	141mm	86mm	850mm 33 15/32"
M473	30	40	160mm	105mm	888mm
M473	30	40	176mm	63mm	1000mm 39 3/8"

*Citroën DS 3 NOTE: Please refer to www.rhinorack.com/fit-my-car/select-vehicle for supplement fitting instruction.



Instruction below for Mazda 2, Mazda CX-3, Mazda CX-5, Mazda CX-9

Tools Required; Tape measure, Marking pen, Drill, Ø11mm Drill bit.

1 Move to the rear of the vehicle and locate the end of the roof ditch mould. Carefully lift & unclip the roof ditch mould from the rear then move towards the front unclipping along the way.

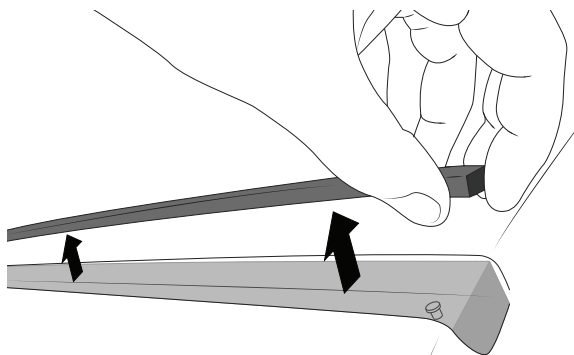

3 With the roof ditch mould now marked, use an 11mm drill bit and carefully drill two holes in each roof ditch mould.

Use a deburring tool to tidy edges

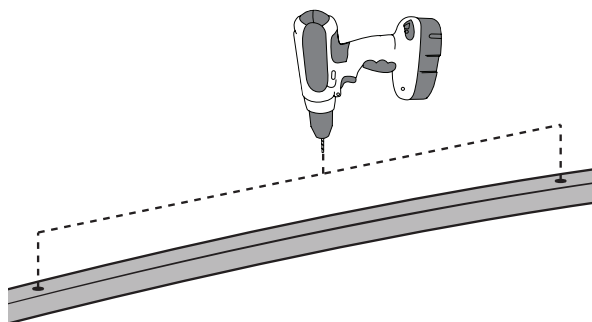

2 Lay the roof ditch mould on the roof adjacent with the roof ditch itself as shown in Figure 1. Mark the centre of the roof ditch mould in line with the threaded mounting points found in the roof ditch. Use the measurements in Figure 2 as a guide. Always physically check against the vehicle.

Figure 1.

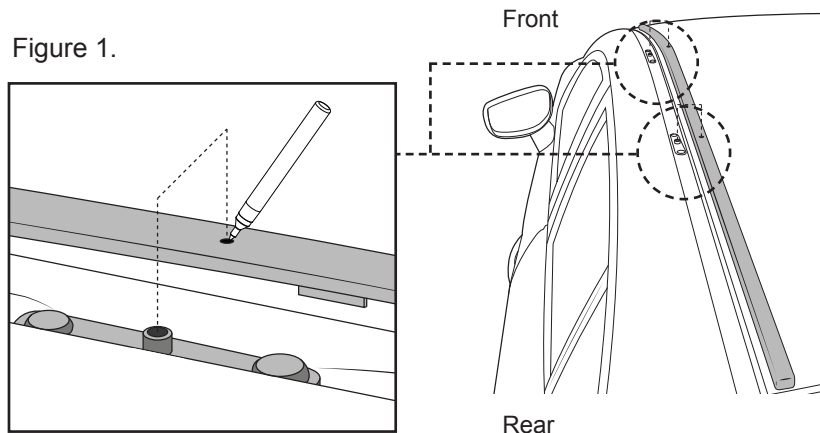
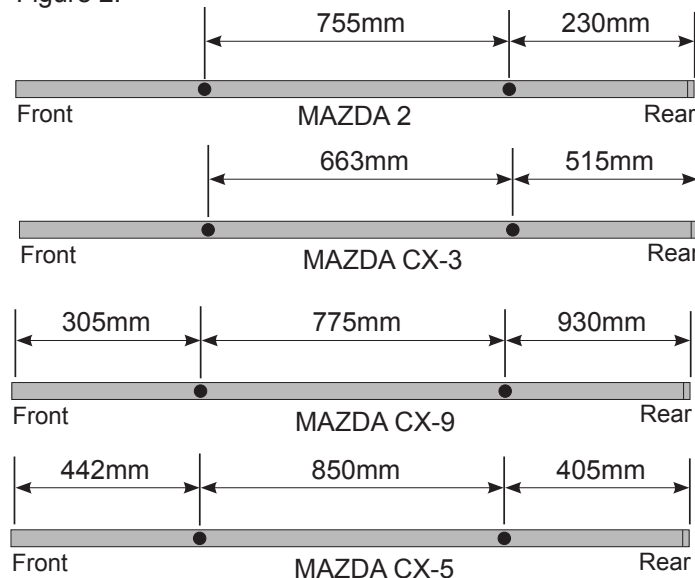
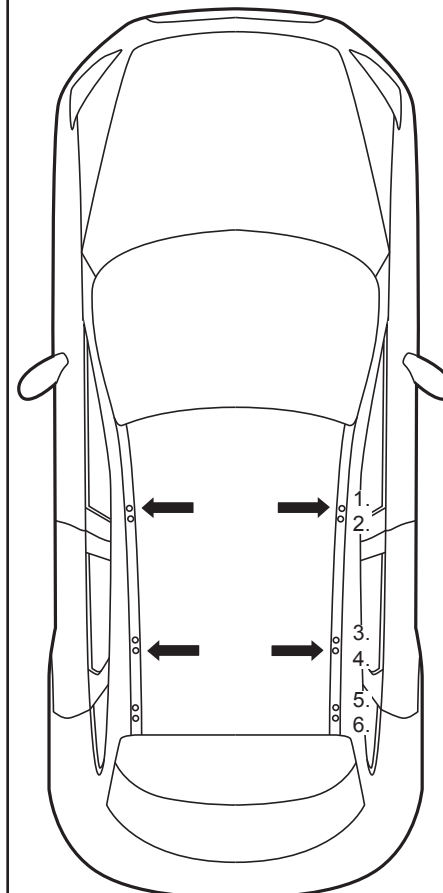

Figure 2.



MAZDA CX-9

From the front of the vehicle, use factory mounts 1 and 4.





- 4** Clip the roof ditch mould back into the roof.
Repeat previous steps for opposite side of the vehicle.

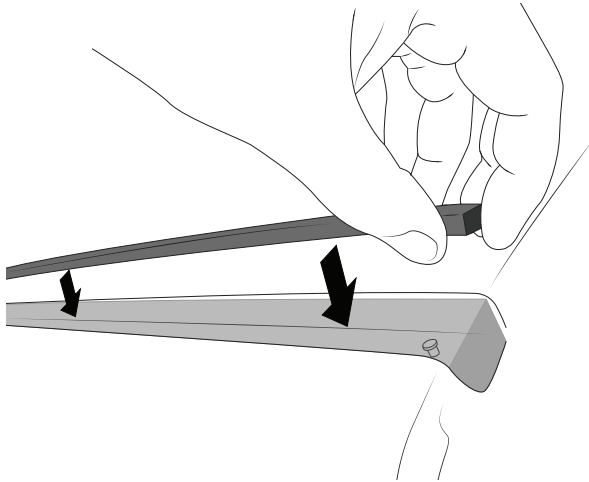

- 5** Insert the M6 threaded studs through the holes then fasten to the vehicles mounting points, finger tighten.

