

MAXIMUM PRODUCT LOAD RATING: 100 kg 

IMPORTANT:

- **LOAD = WEIGHT OF PLATFORM or BARS + MOUNTING SYSTEM + ACCESSORIES + CARGO**
- **PLEASE REFER TO VEHICLE MANUFACTURER SPECIFICATIONS FOR MAX ROOF LOAD CAPACITY OF VEHICLE. THE LOWEST LOAD RATING APPLIES.**
- **OFFROAD RATING: SCAN QR CODE FOR LOCKNLOAD LOAD RATING GUIDE. REDUCTIONS MAY APPLY.**



FIRST TIME INSTALLATION

- Please read instructions carefully before installation.
- Check the contents of kit. Each spine has the last four digits of the kit's part number lasered in. Contact your YAKIMA dealer if any parts appear missing, incorrect or damaged.
- Clean your roof thoroughly prior to fitting the LockNLoad RuggedLine.
- Place these instructions in the vehicle's glove box after installation is complete.



TOOLS REQUIRED:

- Plastic Scraper Tool
- Measuring Tape
- Marking Pen
- Power or Cordless Drill
- 3 & 9 mm Drill Bit
- 5 mm Drill Stop
- Vacuum Cleaner
- Zinc Rich Cold Galvanising Coating
- Rivnut Tool
- 13 mm Spanner
- Cutters/Scissors
- Torque Wrench

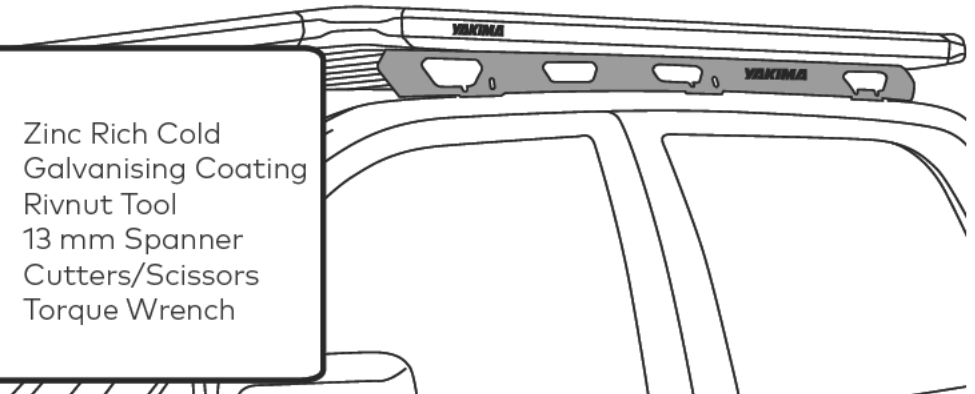

KIT CONTENTS

ITEM	COMPONENT	QTY	ITEM	COMPONENT	QTY
1.	RAM 1500 Left Spine 1015	x1	9.	M6 Washer	x12
2.	RAM 1500 Right Spine 1015	x1	10.	M6 Rivnut	x12
3.	Pivot Bracket Assembly	x4	11.	Foam Adhesive	x12
4.	M8 Socket Head Capscrew 20 mm	x4	12.	Loctite 598 Tube	x1
5.	M8 Washer	x8	13.	4 mm T Handle Ball End Allen Key	x1
6.	M8 Nyloc Nut	x4	14.	5 mm T Handle Ball End Allen Key	x1
7.	M6 Socket Head Capscrew 20 mm	x12	15.	6 mm T Handle Ball End Allen Key	x1
8.	M6 Spring Washer	x12			



**PLATFORM & COMPONENTS SOLD SEPARATELY
RECOMMENDED PLATFORM SIZE IS 'S' (9820378)**

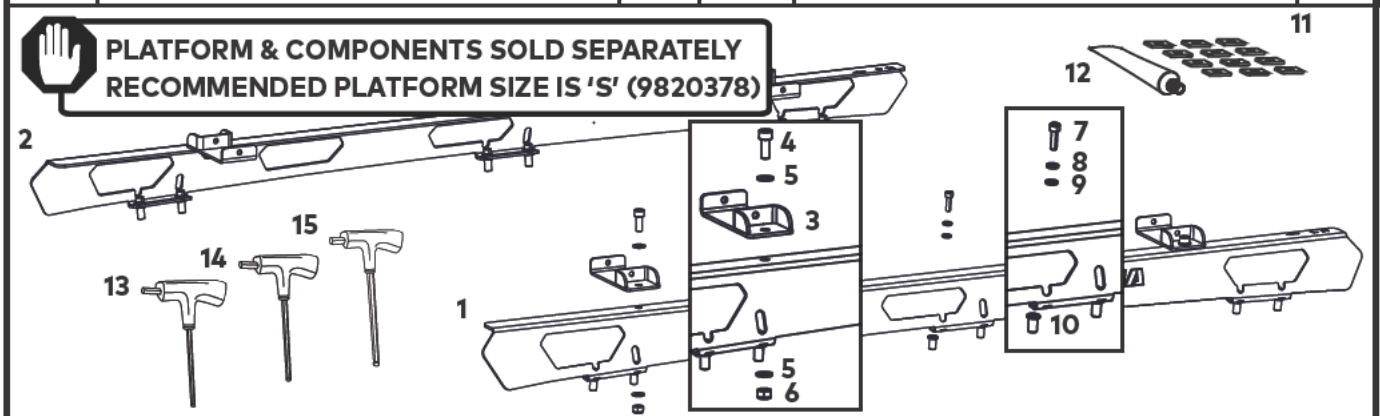

REMOVING ROOF TRIM AND DRILLING ROOF CHANNEL

1 REMOVE RUBBER ROOF TRIM AND CLEAN DOUBLED SIDED TAPE

Remove rubber roof channel trim using fingers.

Using a Plastic Scraper Tool, clean off any remaining doubled sided tape in the roof channel.

Store channel trim in a safe location for use in Step 7, page 6.

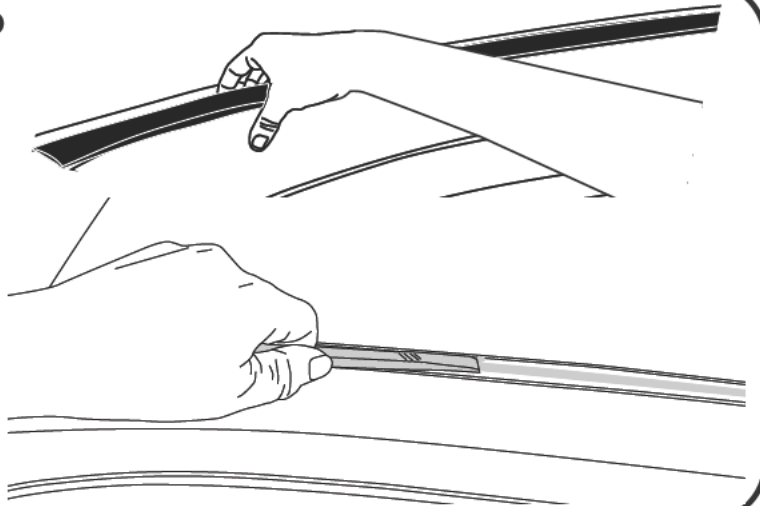

2 MEASURE AND MARK ROOF CHANNEL

Using a Measuring Tape, measure 340 mm back from the start of the windscreen and mark measurement on roof channel with a Marking Pen as shown.

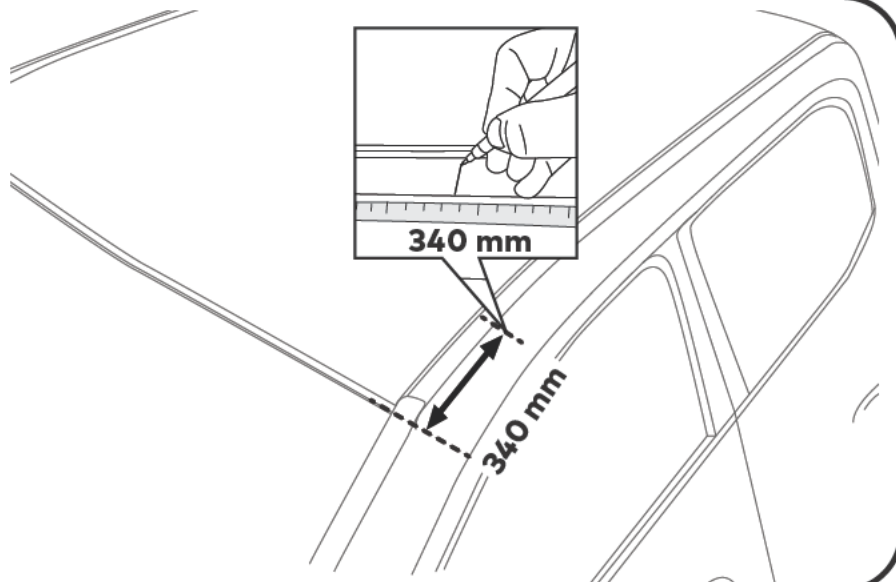

3 POSITION RUGGEDLINE ON ROOF CHANNEL

Referring to the left-right orientation on top of each Spine, carefully place the side of the RuggedLine that matches the side of the vehicle with the marked measurement onto vehicle roof channel, lining up the front facing edge of the first tab to the 340 mm measurement as shown.

Front of vehicle

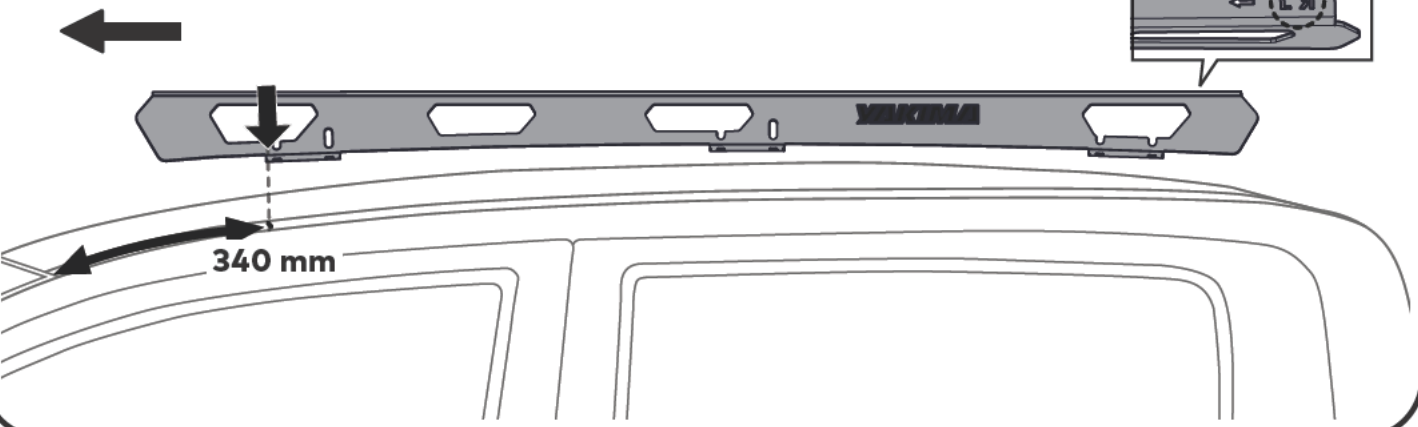

4**MARK DRILL HOLES ON ROOF CHANNEL**

With the help of a friend, securely hold RuggedLine Spine in place and mark all drill holes through the tabs on spine into the roof channel with a Marking Pen.

Remove RuggedLine from roof.

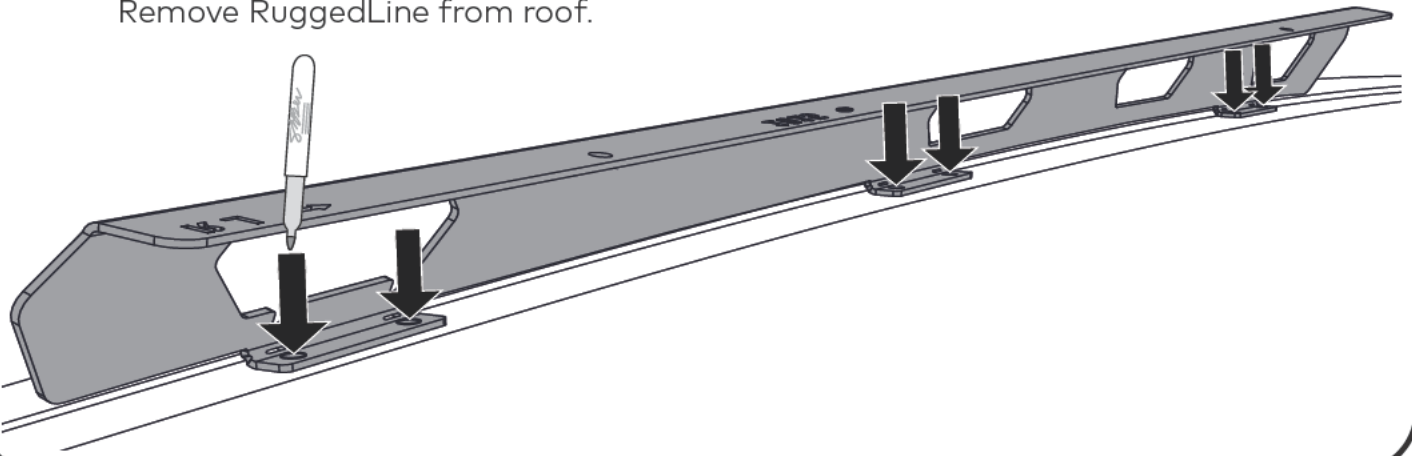
**5****DRILL MARKED HOLES**

Using a 5 mm Drill Stop and 3 mm Drill Bit (not supplied), drill pilot holes at the marked locations, then open out holes using a 5 mm Drill Stop and 9 mm Drill Bit (not supplied) to drill through the vehicle roof.

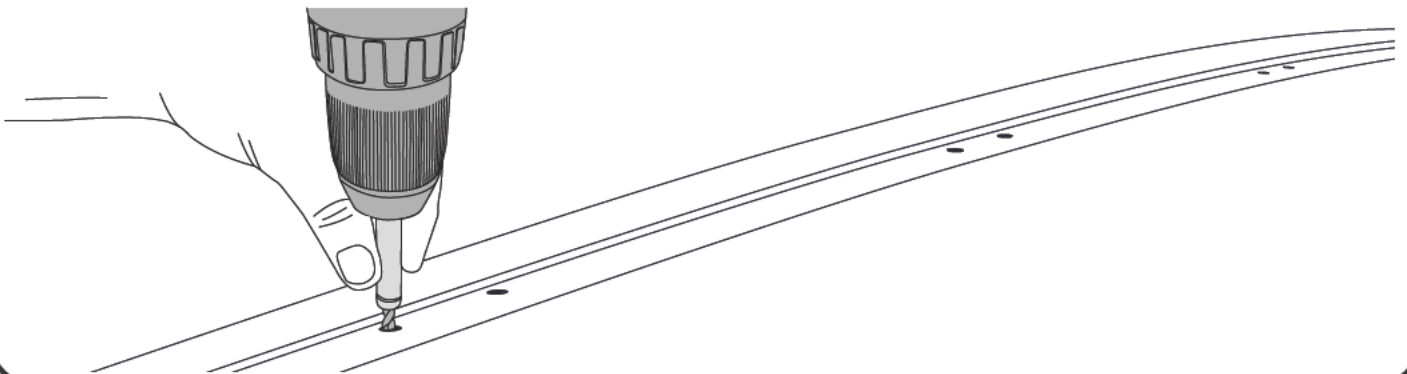
**6****REMOVE SWARF**

Avoid pushing swarf into the newly drilled holes by removing swarf from roof channel with a Vacuum Cleaner.

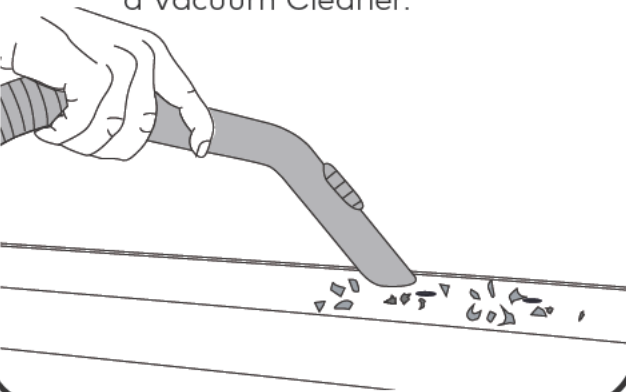
**7****APPLY GALVANISING SOLUTION**

Liberaly apply a Zinc Rich Cold Galvanising Solution to the inside surface and surrounds of each hole. Allow solution to become touch dry (approx. 10 min depending on product used).

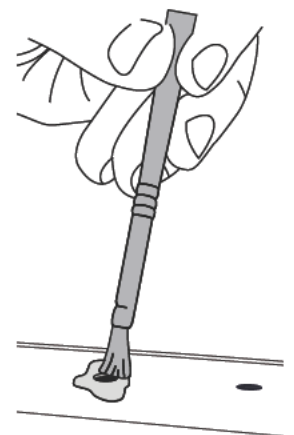

Apply liberally in and around holes

8**INSTALL RIVNUTS**

Install the Rivnuts into each of the drilled holes using a Rivnut Tool.

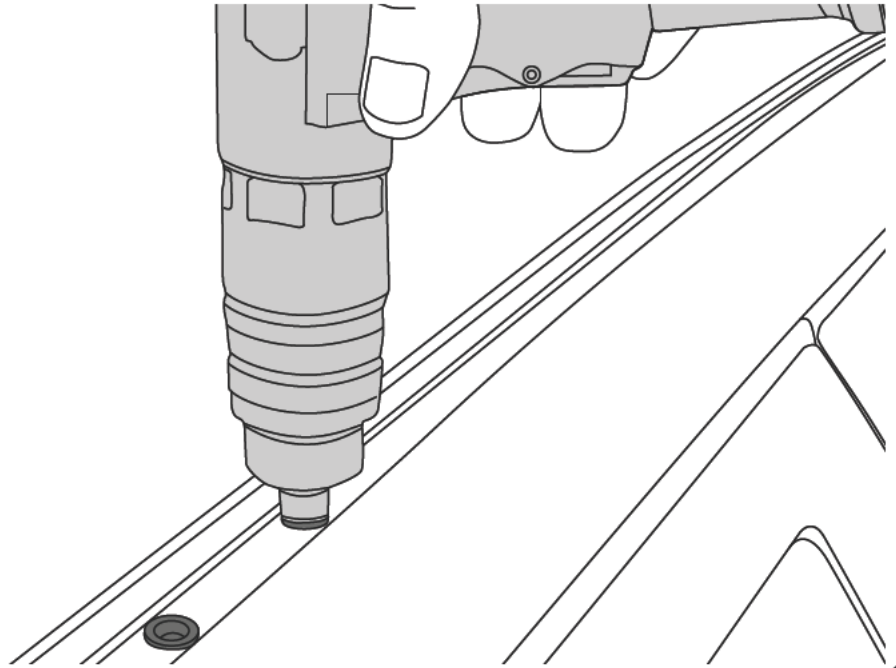
**9****AFFIX FOAM ADHESIVE**

Carefully apply Foam Adhesive over all the Rivnuts in roof channel, lining up holes in foam with the holes in roof channel.

Apply with adhesive side to vehicle.

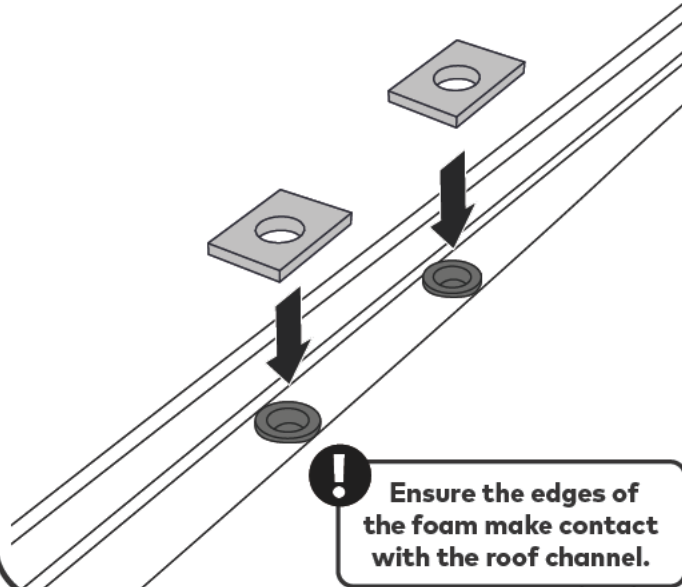
**10****APPLY LOCTITE**

Liberal apply the supplied Loctite to the inside surface and on top of all holes **on one side of vehicle.**

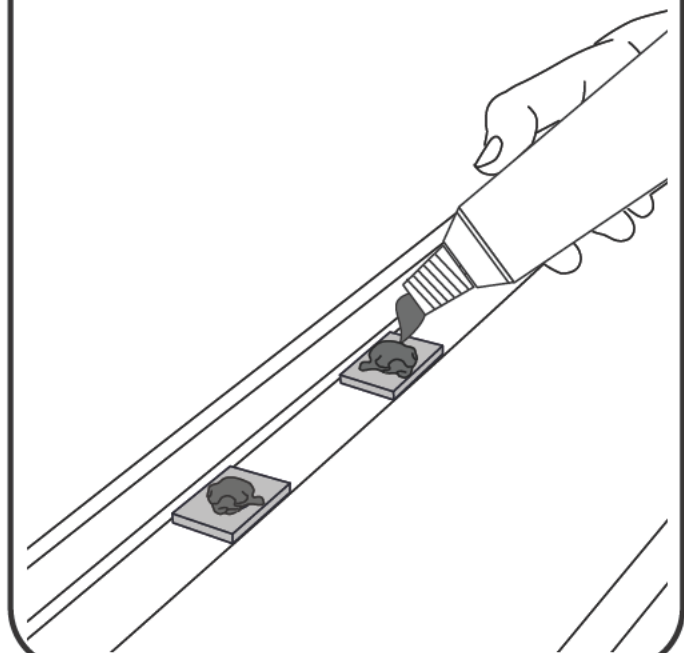

MOUNTING RUGGEDLINE AND LOCKLOAD PLATFORM

1

ASSEMBLE PIVOT BRACKET TO RUGGEDLINE

Assemble Pivot Bracket and M8 hardware as pictured. Complete this for the 2 mounting holes on top of the RuggedLine Spine.

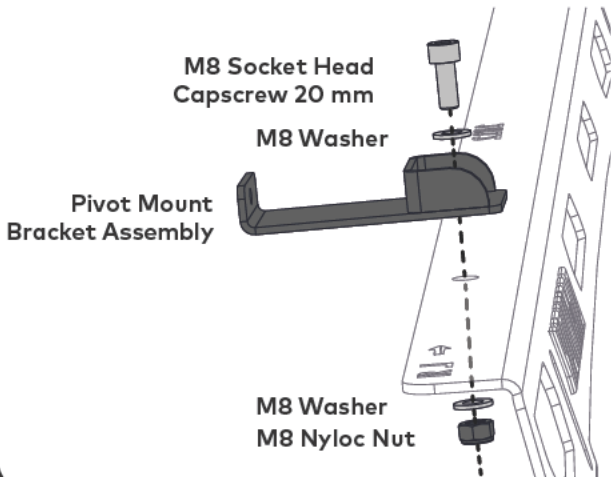

2

SECURE PIVOT BRACKET ASSEMBLIES

Tighten all Capscrews with the provided 6 mm T Handle Ball End Allen Key, and all Nuts with a 13 mm Spanner or a suitable Torque Wrench

Ensure all Capscrews and Nuts are tightened to 7 Nm.

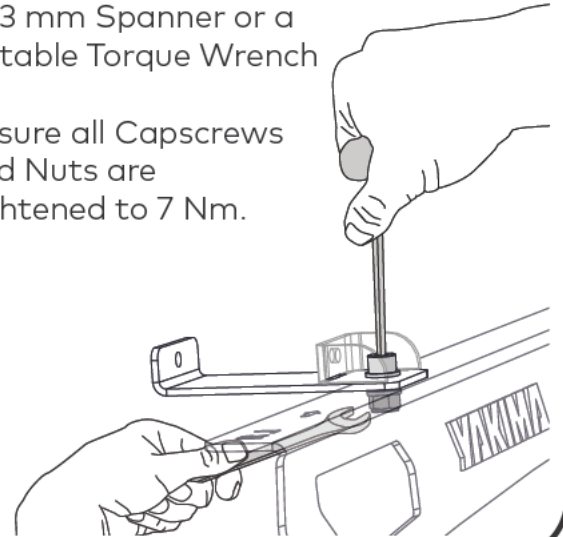

3

POSITION RUGGEDLINE ON VEHICLE ROOF

Referring to the left-right orientation on top of each Spine, carefully place the correct side of the RuggedLine onto vehicle roof as shown. Line up the mounting holes on the bottom tabs to those exposed on the roof. The tabs are to face in towards the vehicle.

Front of vehicle

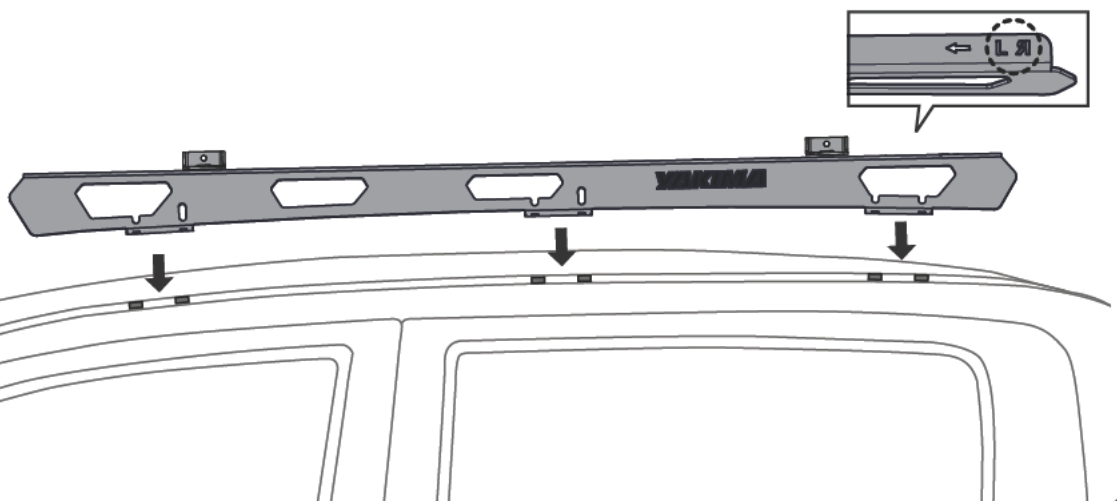

4**ASSEMBLE RUGGEDLINE HARDWARE**

Assemble the M6 Socket Head Capscrew, M6 Spring Washer and Washer as shown and place into mounting holes on bottom tabs of RuggedLine. Ensure hardware and holes align with the Rivnuts in roof.

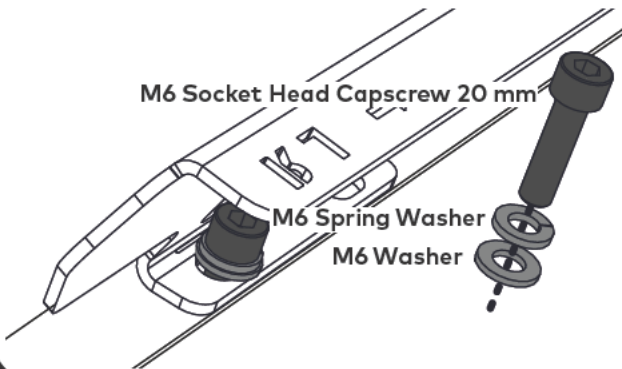
**5****TIGHTEN RUGGEDLINE HARDWARE**

Using the 5 mm T Handle Ball End Allen Key, and avoiding damage to the powder coat, start to carefully secure the RuggedLine by tightening the M6 Socket Head Capscrews to 4 Nm into the Rivnuts in roof.

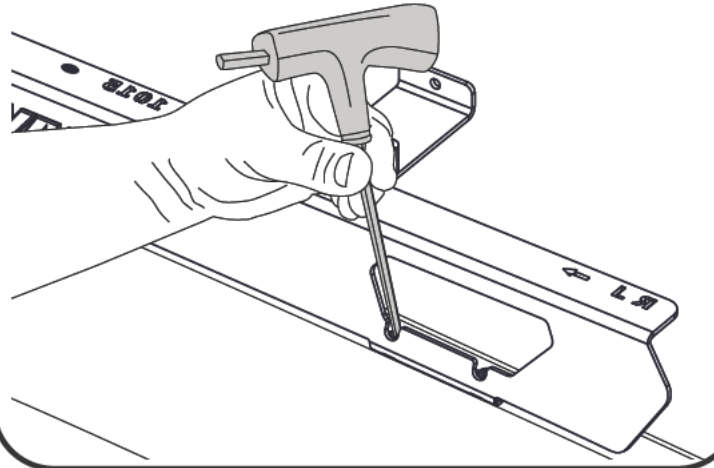
**6****REPEAT STEPS TO OPPOSITE SIDE**

Repeat steps 1-10 on pages 2-4 and steps 1-5 on pages 5-6 for securing opposite side of RuggedLine Spine.

Ensure both Spines are securely positioned on vehicle roof. Check each screw is secure before proceeding to install LockNLoad Platform to RuggedLine Spines.

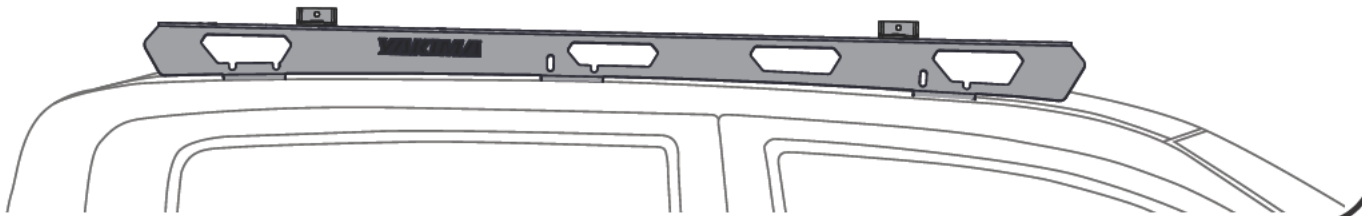
**7****CUT AND REFIT ROOF TRIM**

Line up roof trim removed in Step 1 against the Spines to measure and mark to allow fitment around the tabs. Use a pair of Cutters/Scissors to cut to length and clean off and re-apply any doubled sided tape as necessary.

Re-fit trim pieces around RuggedLine Spines in roof channel.

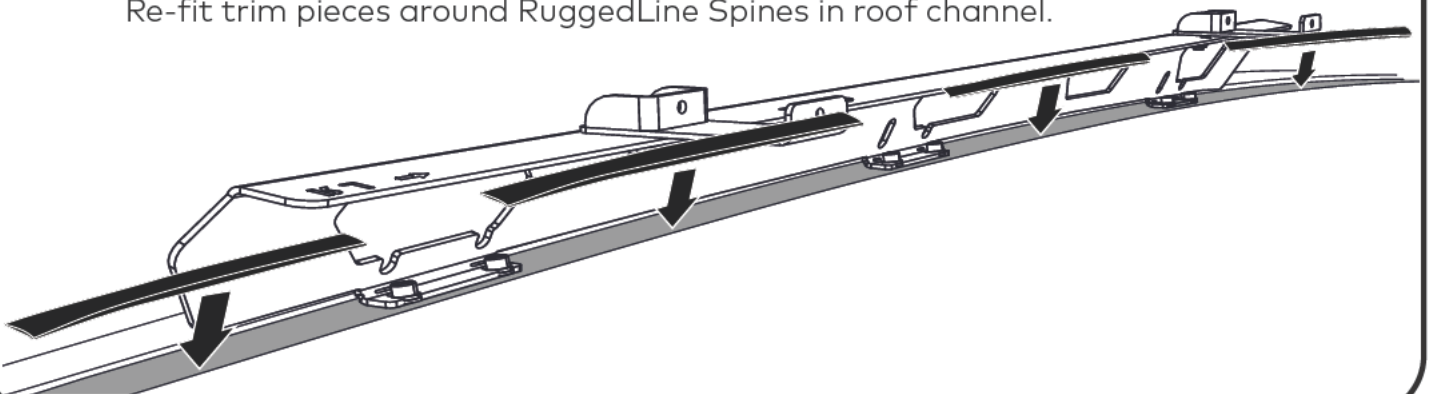

8**INSTALL PLATFORM PIVOT MOUNTS**

From the LockNLoad Platform kit (sold separately), position Pivot Mounts into each Pivot Bracket Assembly, lining up the rivnut holes on the Mounts with the holes on the brackets.

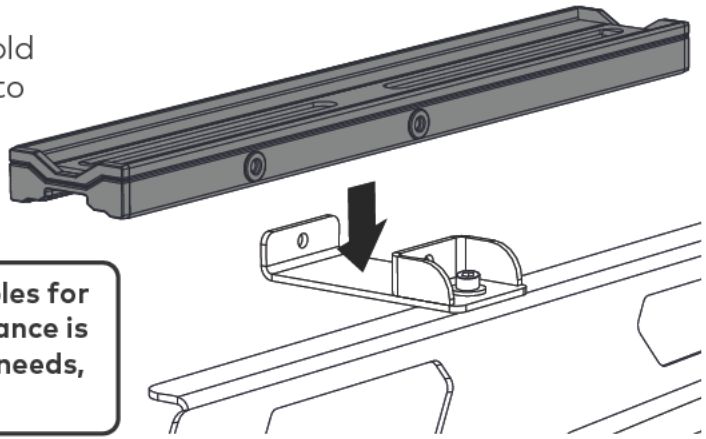
**!**

Where possible, always use the centre holes for attaching to Pivot Bracket. If extra clearance is needed due to Platform-to-roof fitment needs, the offset holes can be used.

9**SECURE PLATFORM PIVOT MOUNTS**

Secure all Platform Pivot Mounts with 2x 16 mm M6 Capscrews with Washer from LockNLoad Platform kit as shown.

Tighten all Capscrews to 4 Nm with the provided 4 mm Ball End Allen Key or a suitable Torque Wrench.

NOTE - The Pivot Mount assembly will still have movement after securing which is intended.

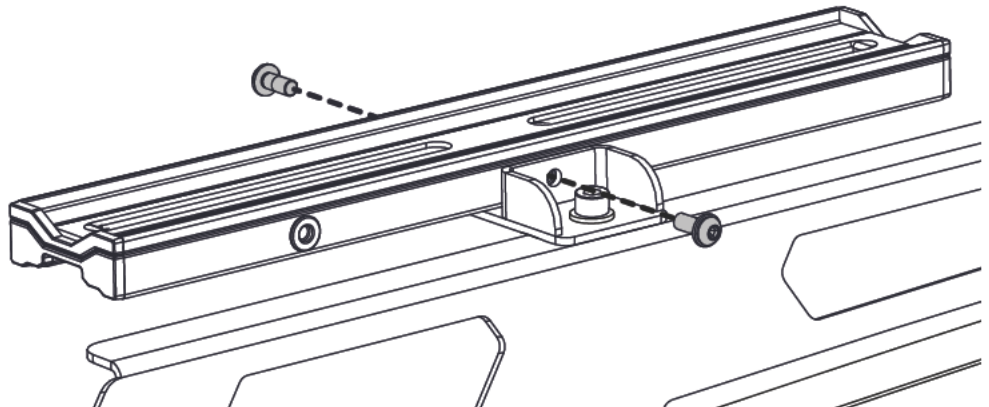
**!**

NOW SWITCH TO YOUR LOCKNLOAD PLATFORM INSTRUCTIONS AND CONTINUE FROM THE 'VEHICLE MOUNTING INSTRUCTIONS' PAGE.

YAKIMA

www.yakima.com.au

www.yakima.co.nz

www.yakima.com

www.yakima.eu

YAKIMA AUSTRALIA PTY LTD

17 Hinkler Court
Brendale, QLD 4500
Australia
1800 143 548

YAKIMA PRODUCTS, INC.

4101 Kruse Way
Lake Oswego, OR
97035-2541
USA
888 925 4621

ALL CONTENT SUBJECT TO YAKIMA AUSTRALIA PTY LTD COPYRIGHT © 2021