

MAXIMUM PRODUCT LOAD RATING: 100 kg 

IMPORTANT:

- **LOAD = WEIGHT OF PLATFORM or BARS + MOUNTING SYSTEM + ACCESSORIES + CARGO**
- **PLEASE REFER TO VEHICLE MANUFACTURER SPECIFICATIONS FOR MAX ROOF LOAD CAPACITY OF VEHICLE. THE LOWEST LOAD RATING APPLIES.**
- **OFFROAD RATING: SCAN QR CODE FOR LOCKNLOAD LOAD RATING GUIDE. REDUCTIONS MAY APPLY.**



FIRST TIME INSTALLATION

- Please read instructions carefully before installation.
- Check the contents of kit. Each spine has the last four digits of the kit's part number lasered in. Contact your YAKIMA dealer if any parts appear missing, incorrect or damaged.
- Clean your roof thoroughly prior to fitting the LockNLoad RuggedLine.
- Place these instructions in the vehicle's glove box after installation is complete.



TOOLS REQUIRED:

- 13 mm Spanner
- 10 mm Socket Wrench
- Trim Removal Tool

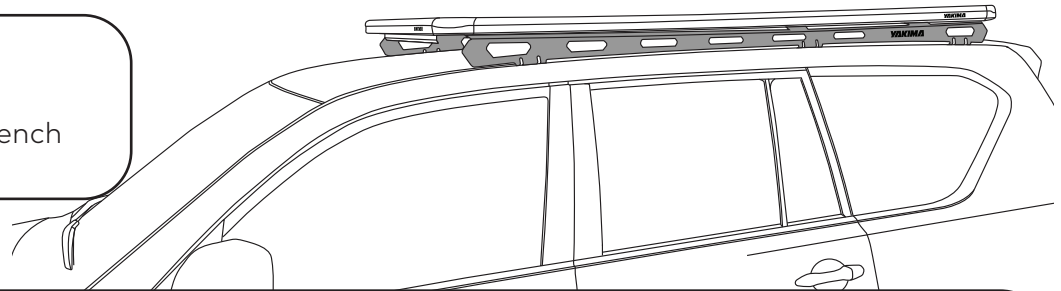

KIT CONTENTS

ITEM	COMPONENT	QTY	ITEM	COMPONENT	QTY
1.	Pajero Sport RH Spine 2114	x1	7.	M6 x 16 mm Capscrew Socket Head	x10
2.	Pajero Sport LH Spine 2114	x1	8.	M6 x 16 mm Washer	x10
3.	Pivot Bracket Welded Assembly	x6	9.	M6 Spring Washer	x10
4.	M8 x 20 Capscrew Socket Head	x6	10.	28 x 20 x 3 Foam Adhesive	x10
5.	M8 Washer	x12	11.	4 mm Ball End Hex Key	x1
6.	M8 x 1.25 Nut Nyloc	x6	12.	5 mm Ball End Hex Key	x1
			13.	6 mm Ball End Hex Key	x1



**PLATFORM & COMPONENTS SOLD SEPARATELY
RECOMMENDED PLATFORM SIZE IS 'E' (9820341)**

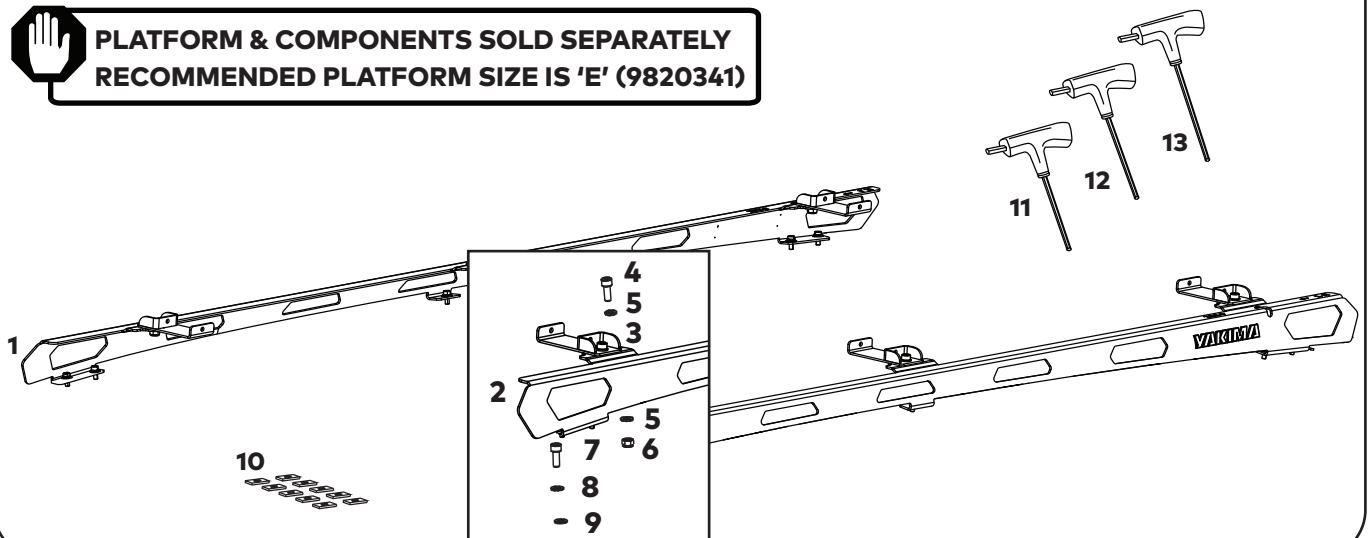

REMOVING FACTORY FLUSH ROOF RAILS

1 UNCLIP PLASTIC RAIL END COVERS

Using an appropriate Trim Remover Tool (or tape wrapped Flat Head Screwdriver), wedge the rail covers upwards to release the internal clips.

! Avoid touching vehicle body when levering covers.

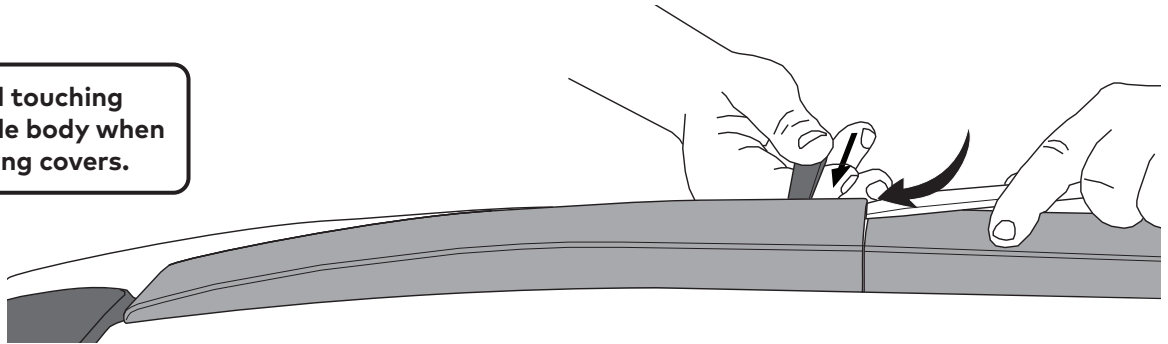

2 LIFT PLASTIC RAIL COVERS

Lift the front of the rail covers up with caution. Lift outwards to avoid damage to rail.

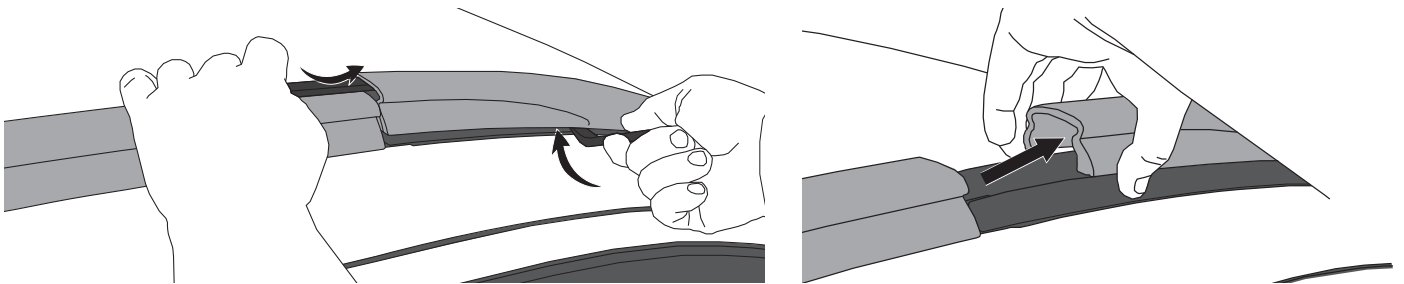

3 LOOSEN BOLT

Remove exposed hardware (x3 bolts at each rail ends) using a 10 mm Socket Wrench.

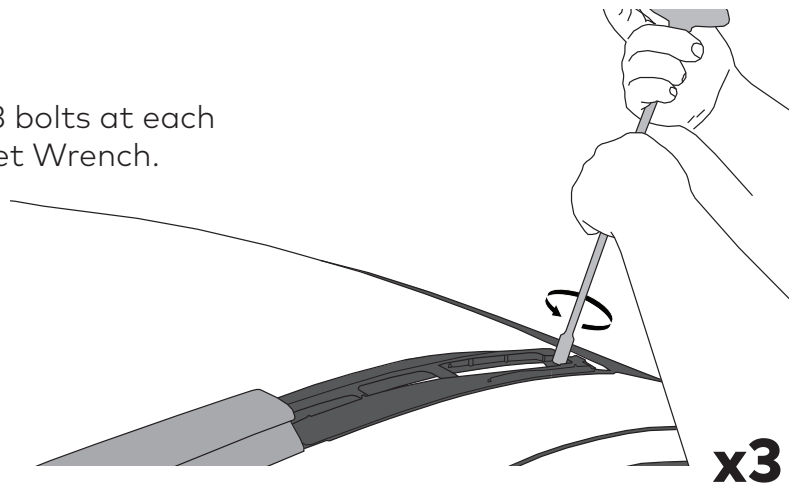

Complete steps 1-3 for the rear cover.

Store removed hardware away in a safe place.

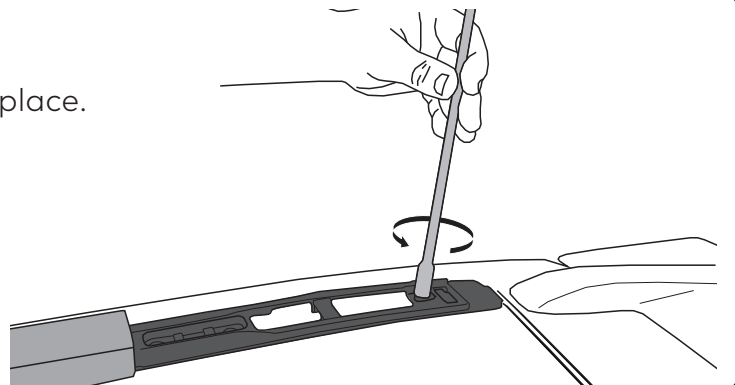

4 REMOVE RAIL CAPS

Using a small screwdriver, remove the rail caps x2 from the rail.

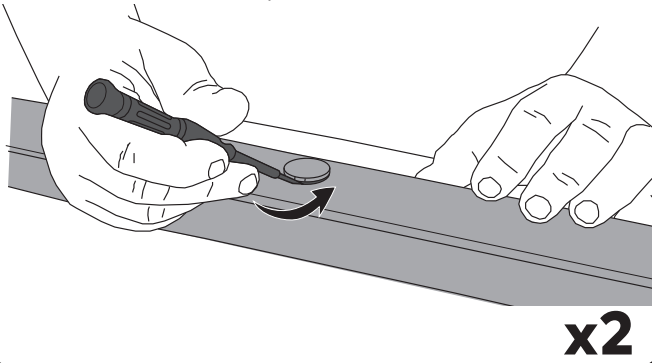

5 LOOSEN BOLTS

Loosen the now exposed bolts (x2) using a 10 mm socket wrench.

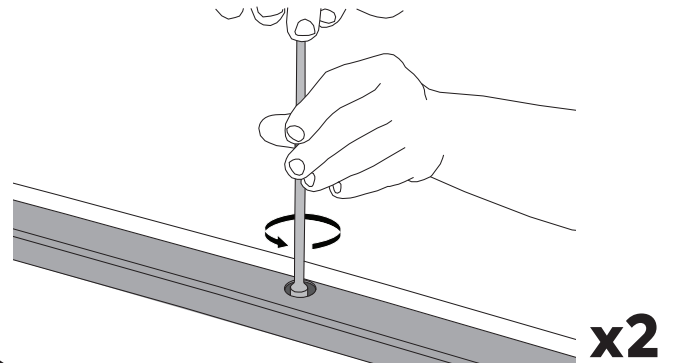

6 REMOVE RAILS

Lift roof rails upwards and carefully remove from the roof.

Store removed rails away in a safe place.



7 CLEAN EXPOSED THREAD

Take care that the thread in the roof has been cleared of all debris and is clean.

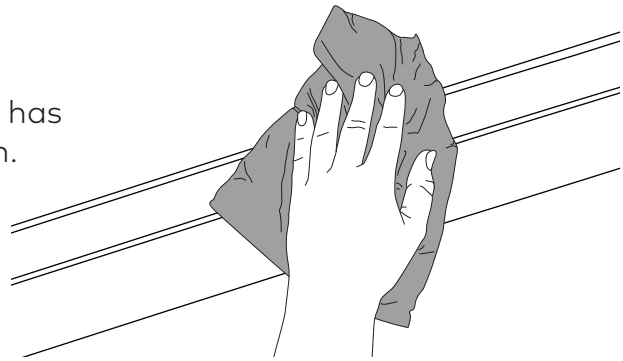

REPEAT STEP 1-7 ON THE OPPOSITE SIDE OF THE VEHICLE.

8 AFFIX FOAM ADHESIVE

Carefully apply Foam Adhesive over all the exposed holes in roof channel, lining up holes in foam with the holes in roof channel. Apply with adhesive side to vehicle.

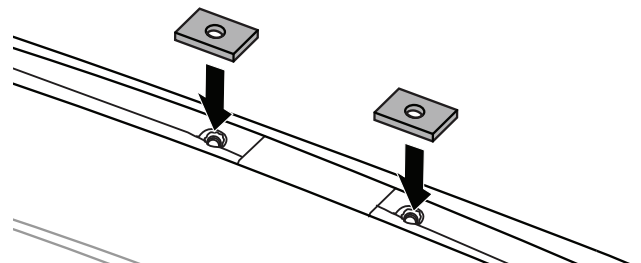

9 ASSEMBLE PIVOT BRACKET TO RUGGEDLINE

Assemble Pivot Bracket and M8 hardware as pictured. Complete this for the 3 tabs on top of the RuggedLine Spine.

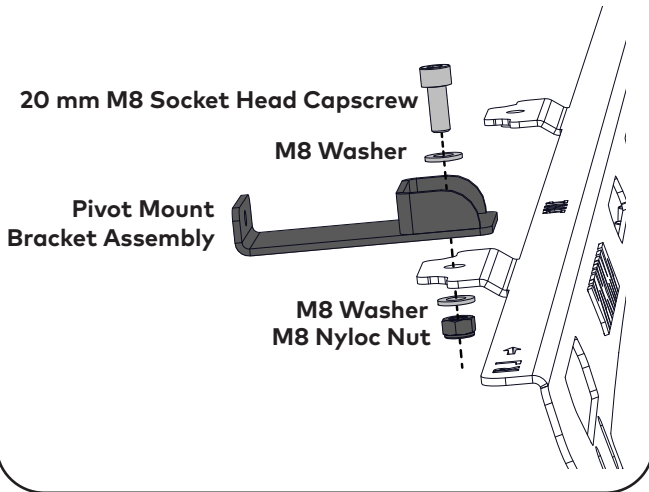

10 SECURE PIVOT BRACKET ASSEMBLIES

Tighten all Capscrews with the provided 5 mm T Handle Ball End Allen Key, and all Nuts with a 13 mm Spanner or a suitable Torque Wrench.

Ensure all Capscrews and Nuts are tightened to 7 Nm.

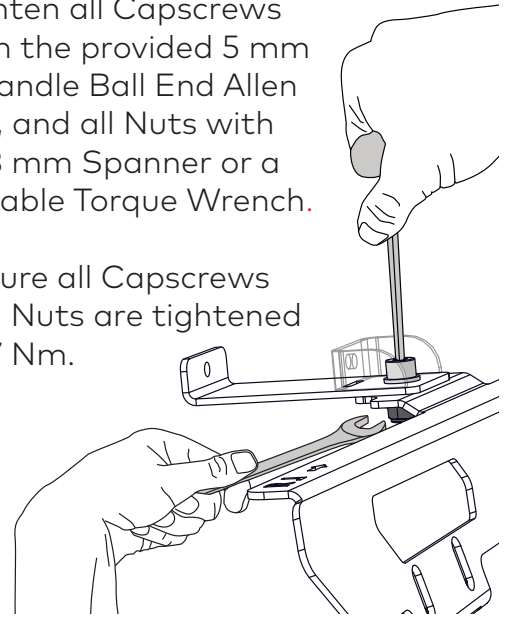

11 INSTALL PLATFORM PIVOT MOUNTS

From the LockNLoad Platform kit, position Pivot Mounts into each Pivot Bracket Assembly, lining up the rivnut holes on the Mounts with the holes on the brackets.

! Where possible, always use the centre holes for attaching to Pivot Bracket. If extra clearance is needed due to Platform-to-roof fitment needs, the offset holes can be used.

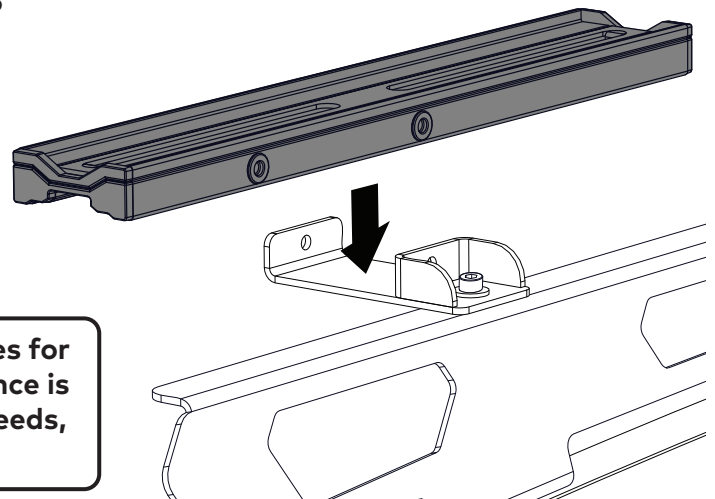

12 SECURE PLATFORM PIVOT MOUNTS

Secure all Platform Pivot Mounts with 2x 16 mm M6 Capscrews with Washer from LockNLoad Platform kit as shown.

Tighten all Capscrews to 4 Nm with the provided 4 mm Ball End Allen Key or a suitable Torque Wrench.

NOTE - The Pivot Mount assembly will still have movement after securing which is intended.

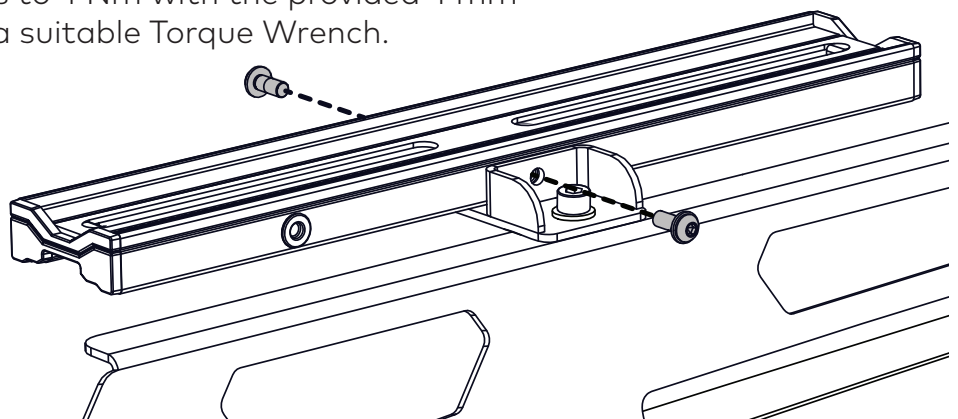

13**POSITION RUGGEDLINE ON VEHICLE ROOF**

Referring to the left-right orientation on top of each Spine, carefully place one side of the RuggedLine onto vehicle roof as shown. Line up the mounting holes on the bottom tabs to those exposed on the roof. The tabs are to face in towards the vehicle.

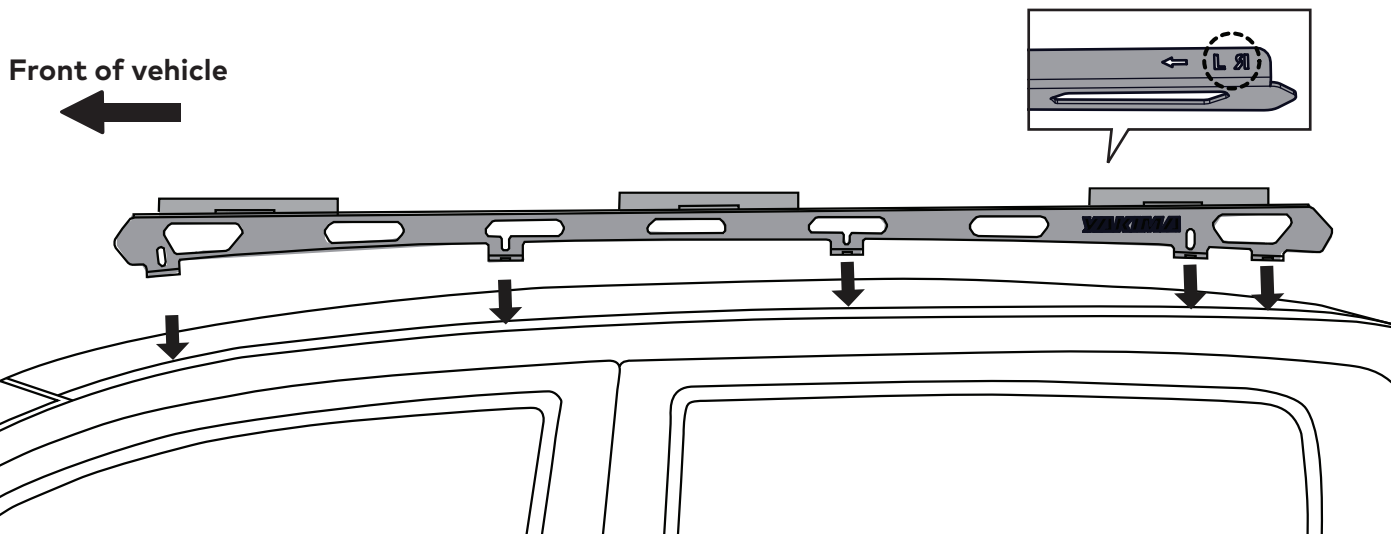
**14****ASSEMBLE RUGGEDLINE HARDWARE**

Assemble the M6 Socket Head Capscrew 16 mm, M6 Spring Washer and Washer as shown and place into mounting holes on bottom tabs of RuggedLine.

Ensure hardware and holes align with the holes on roof.

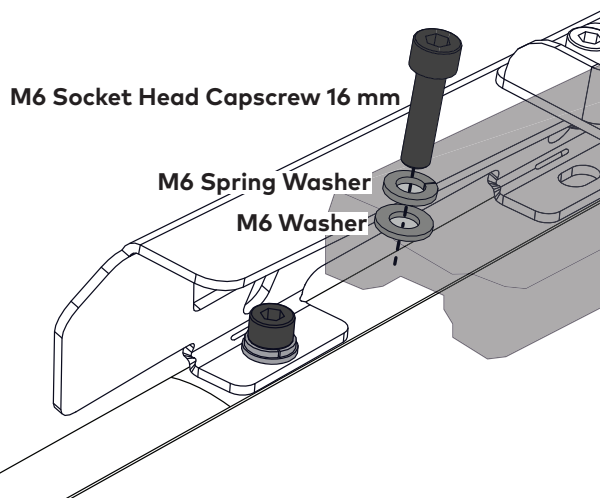
**15****TIGHTEN RUGGEDLINE HARDWARE**

Using the 5 mm T Handle Ball End Allen Key, and avoiding damage to the powder coat, start to carefully secure the RuggedLine by tightening the M6 Socket Head Capscrews to 7 Nm into the mounting holes in roof.

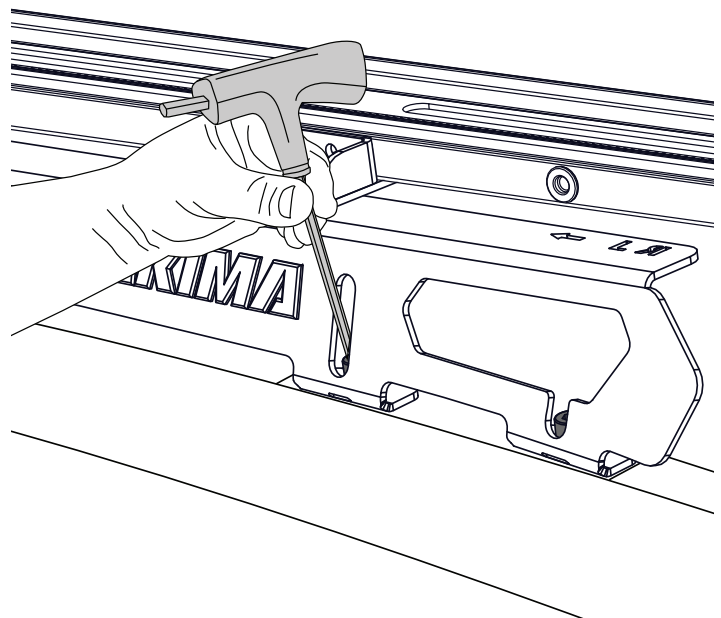

16**REPEAT STEPS TO OPPOSITE SIDE**

Repeat steps 8-15 on pages 4-6 for securing opposite side of RuggedLine Spine.

Ensure both Spines are securely positioned on vehicle roof. Check each screw is secure before proceeding to install LockNLoad Platform to RuggedLine Spines.

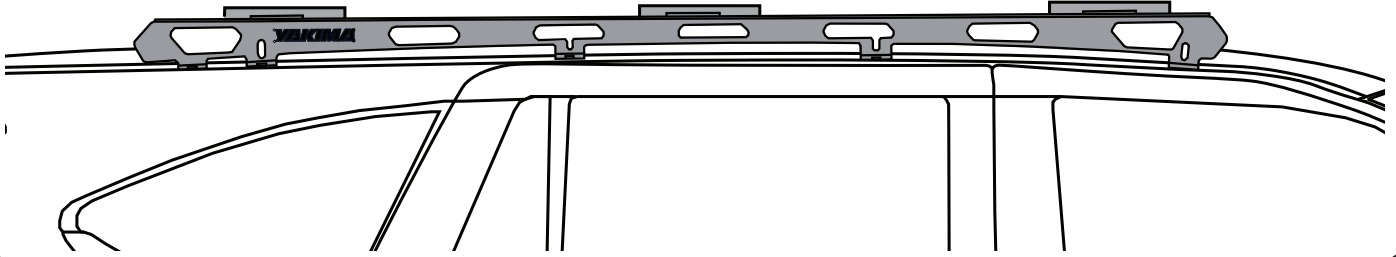

**NOW SWITCH TO YOUR LOCKNLOAD PLATFORM
INSTRUCTIONS AND CONTINUE FROM THE
'VEHICLE MOUNTING INSTRUCTIONS' PAGE.**

This page intentionally left blank



www.yakima.com.au
www.yakima.co.nz
www.yakima.com
www.yakima.eu

YAKIMA AUSTRALIA PTY LTD

17 Hinkler Court
Brendale, QLD 4500
Australia
1800 143 548
yakimaglobal.com

YAKIMA PRODUCTS, INC.

4101 Kruse Way
Lake Oswego, OR
97035-2541
USA
888 925 4621
yakima.com/support