

MAX VEHICLE ROOF LOAD RATING: 100KG

TOTAL LOAD EQUALS WEIGHT OF ROOF RACKS + ACCESSORIES + CARGO

FIRST TIME INSTALLATION

- Please read instructions carefully before installation.
- Check the contents of kit. Contact your YAKIMA dealer if any parts appear missing or damaged.
- Clean your roof thoroughly prior to fitting the LOCKN'LOAD Heavy Duty Roof Rack System.
- Place these instructions in the vehicle's glove box after installation is complete.



TOOLS REQUIRED:

- 13mm & 10mm Socket Wrench
- #2 Phillips Head Screwdriver
- 10mm Combination Spanner
- Torque Wrench (Optional)
- Rubber Mallet (Optional)
- Tape Measure
- Scissors

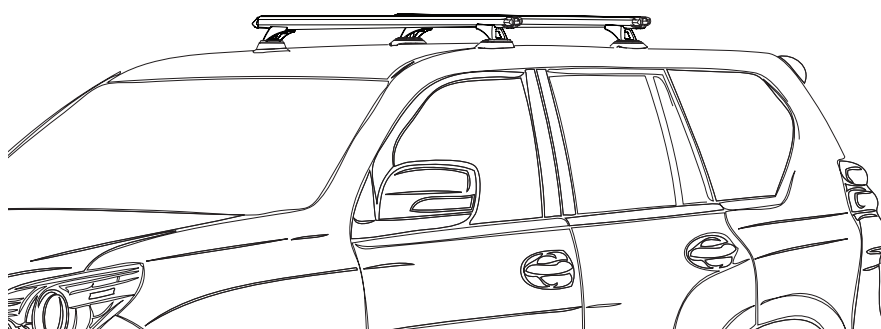

KIT CONTENTS

ITEM	COMPONENT	QTY	ITEM	COMPONENT	QTY
1.	M6 Washer	x4	6.	Front Left Pad (2804021)	x1
2.	M6 Set Screw 30mm	x4	7.	Rear Left Pad (2804022)	x1
3.	M8 Washer	x8	8.	Front Right Pad (2804024)	x1
4.	M8 Hex Bolt 40mm	x8	9.	Rear Right Pad (2804025)	x1
5.	Foam Adhesive	x8			



LEG AND BAR COMPONENTS SOLD SEPARATELY

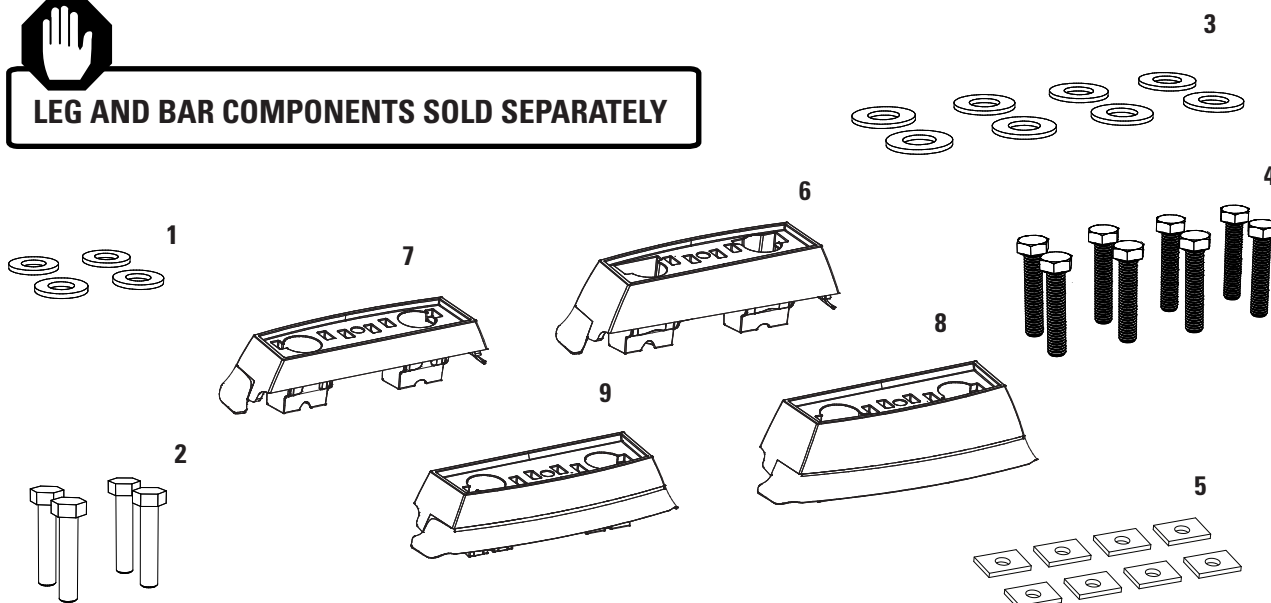

INSTALLATION

1 REMOVE FIXED POINT HARDWARE

Remove fixed-point covers.

Remove bolts, washers and brackets from the vehicle's fixed points.

Store items away in a safe place.

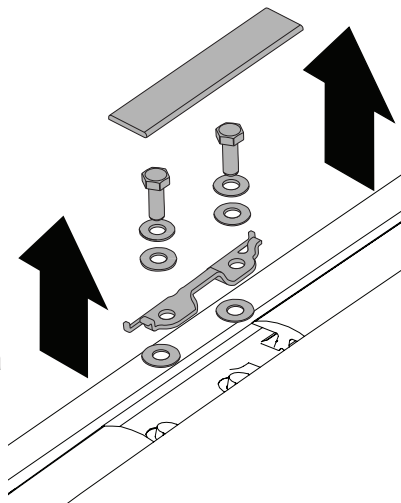

2

Place Foam Adhesive over holes on underside of Pads.

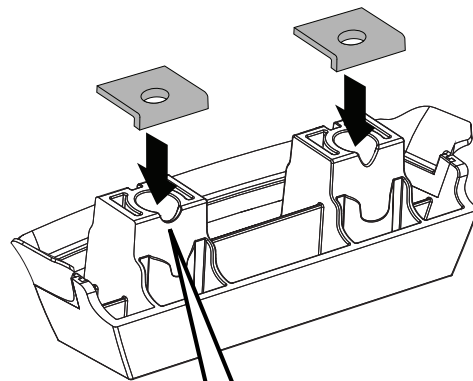

Ensure that the cut out on side of Pad is covered as shown

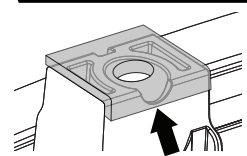

3 PAD POSITIONING

Place Pads over vehicle's fixed points as shown. It is important to put the Pads in the correct position on the vehicle.

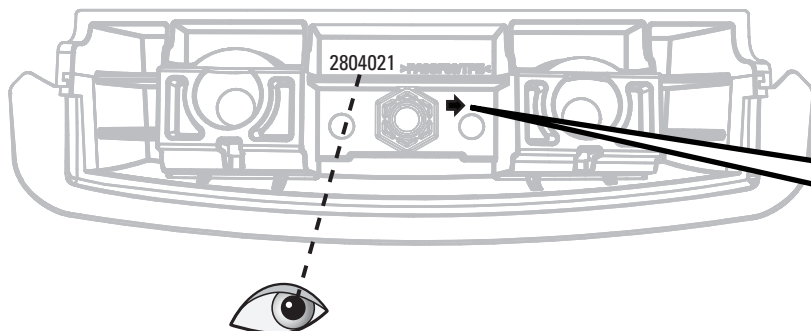

Ensure that the arrows on underside of Pads are facing the front of vehicle

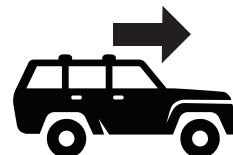

1 = 2804021	2 = 2804022
3 = 2804024	4 = 2804025

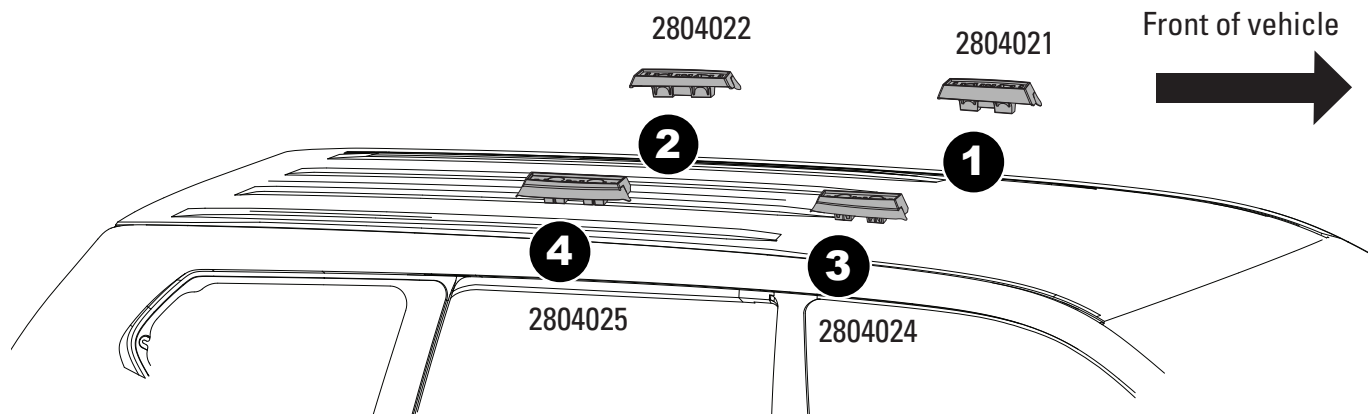

4**SECURE PADS TO FIXED POINTS**

Assemble 1 x M8 Washer onto each M8 Hex Bolt 40mm as shown. Insert into Pads.

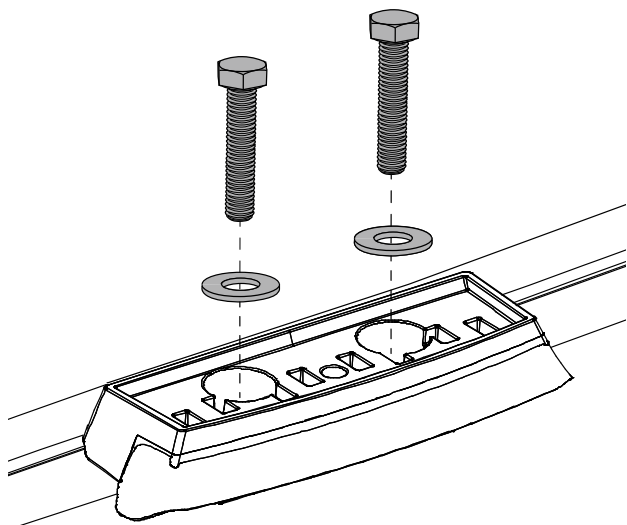
**5**

Tighten all M8 Hex Bolts to 7Nm using 13mm Socket Wrench. Check all Bolts are completely tightened down and secure as required.

Do not over tighten.

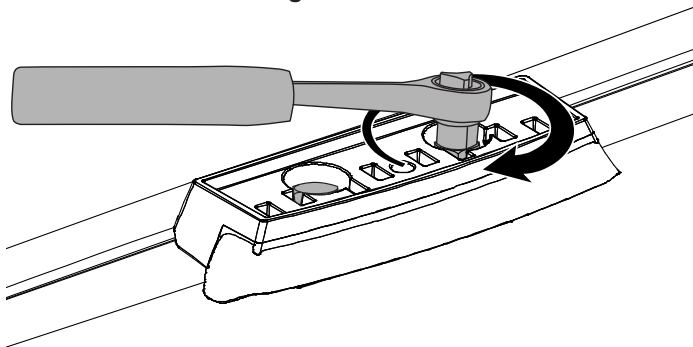
**6****REMOVE LEG COVERS**

Using the keys supplied in the LOCKN'LOAD Leg Kit (sold separately), remove all Leg Covers.

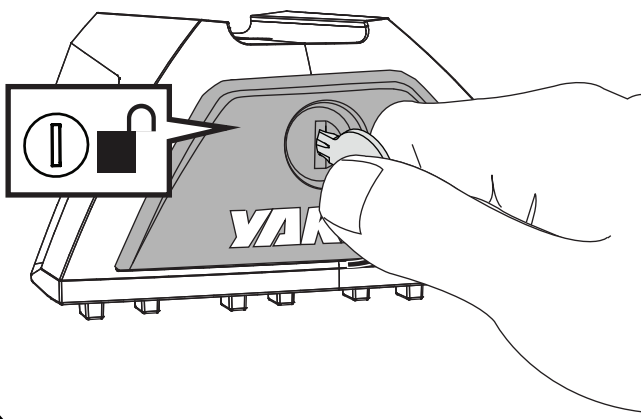
**7****LEG ASSEMBLY**

From the LOCKN'LOAD Leg Kit, position Nut Plates over holes on top of Legs.

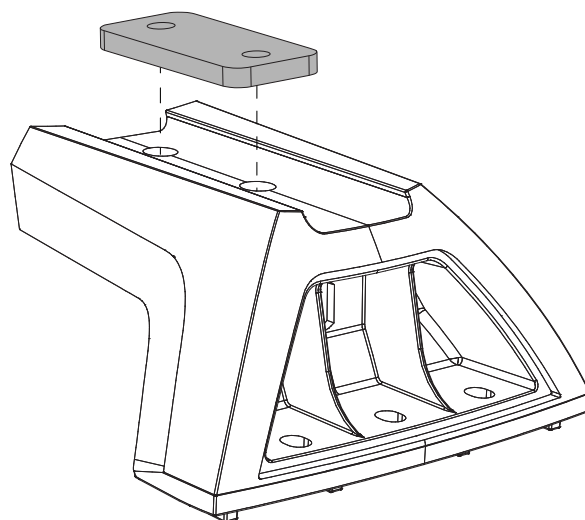
**9**

Loosely finger tighten Nut Plates to Legs as shown using the screw assemblies from the previous step.

Ensure there is a sufficient gap between the Nut Plates and Legs for Step 11.

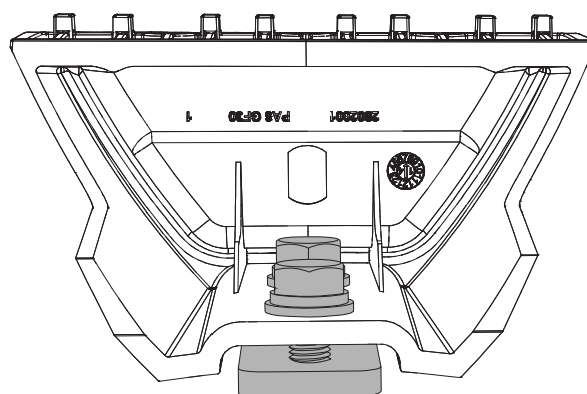
**8**

From the LOCKN'LOAD Leg Kit, assemble 1 x M8 Spring Washer and 1 x M8 Washer onto each M8 Set Screw 16mm in the order shown.

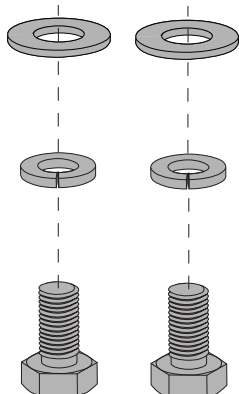

10

BAR SLOT COVERS

From the LOCKN'LOAD Bars (sold separately) cut Bar Slot Covers as per the table and insert into underside channel of each Bar end as shown.

BAR SLOT COVER CUT MEASUREMENTS	
Front Bar	Rear Bar
210mm x2	199mm x2

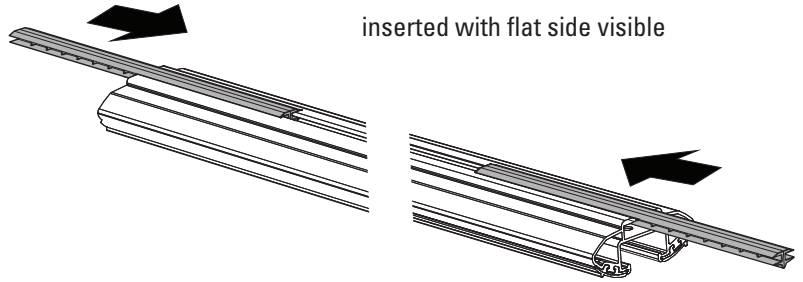
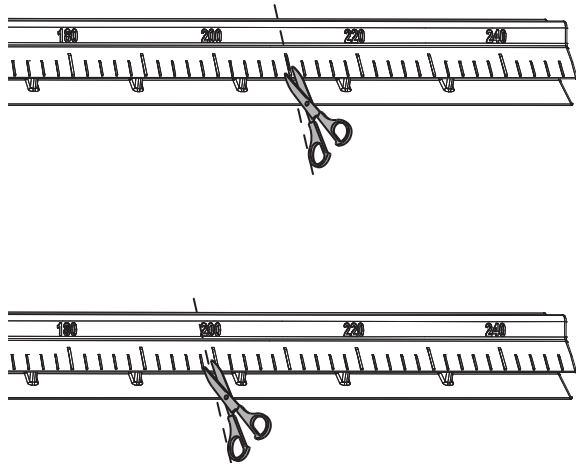

NOTE - Bar Slot Covers to be inserted with flat side visible

11

INSERT LEGS

Slide Leg assemblies into the underside channel of LOCKN'LOAD Bars. Slide in until Leg reaches Slot Cover.

Do not compress slot cover.

If Leg assemblies will not slide in, loosen Screws to increase gap.

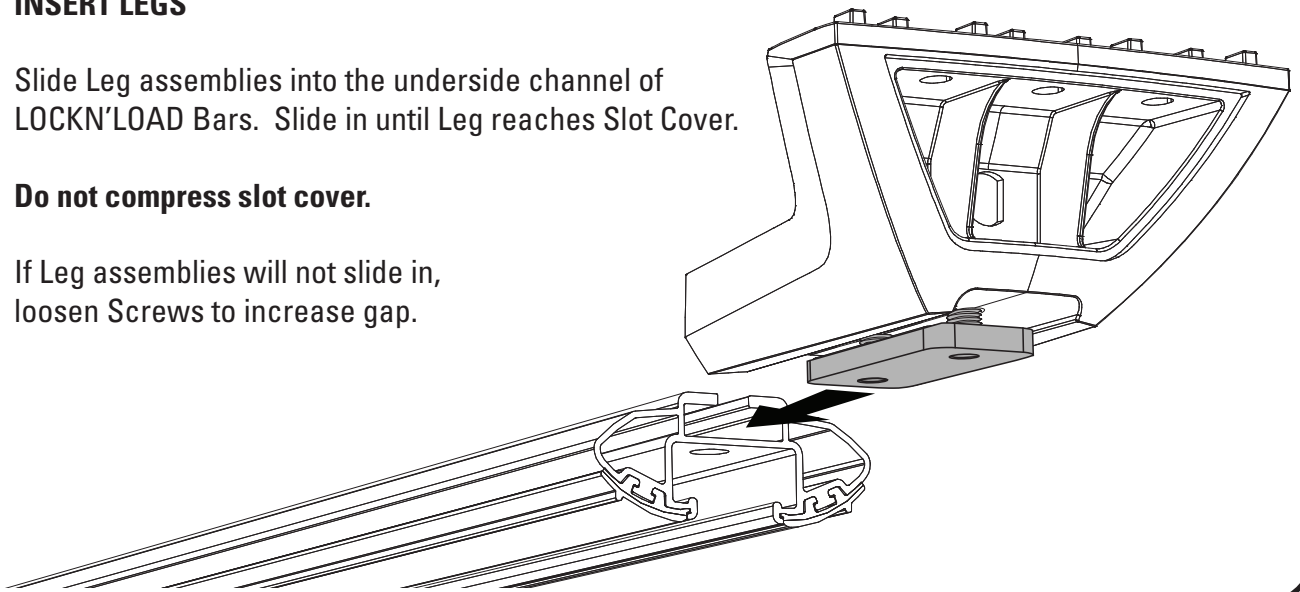

12

CHECK LEG TO LEG MEASUREMENTS

With a Tape measure check leg to leg measurements are correct as per the table. Ensure measurements are taken from the centre of the Legs as shown.

LEG TO LEG MEASUREMENTS	
Front Bar	Rear Bar
1018mm	993mm



13 SECURE LEGS TO BARS

Tighten all M8 Set Screws to 7Nm using 13mm Socket Wrench

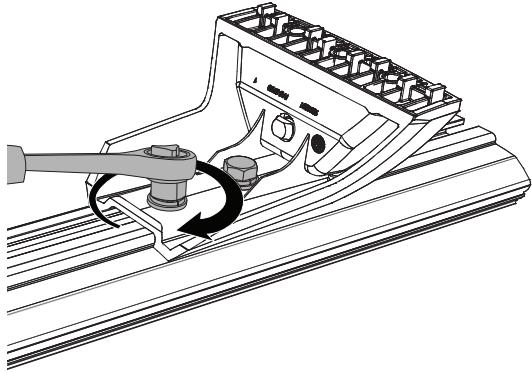

14 BAR SLOT COVERS (OUTSIDE LEG)

Measure the Bar channel outside of the Legs and subtract 20mm from this measurement. Using the remaining pieces of Slot Cover from Step 10, cut to this length and insert into the underside channel of each Bar end as shown.

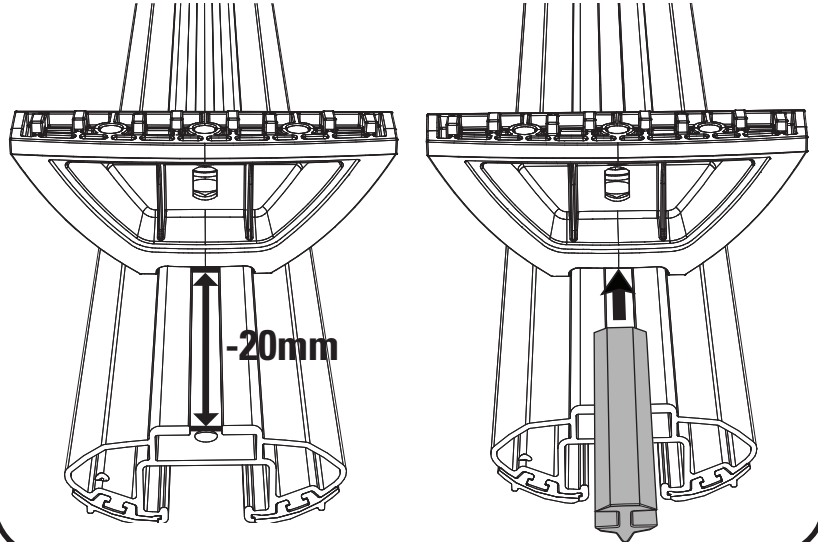

15 END CAP ASSEMBLY

From the LOCKN'LOAD Leg Kit, insert Bottle Openers and Pins into the End Cap Halves.

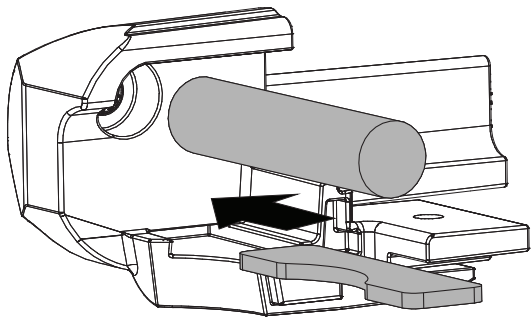

16 Connect all End Cap Halves together.

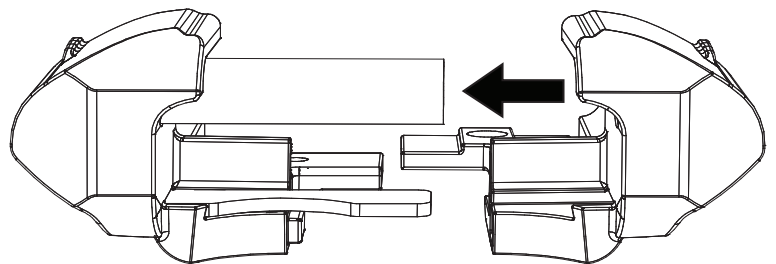

17 SECURE END CAPS TO BARS

Insert the End Caps as shown. A Rubber Mallet can be used to assist installation.

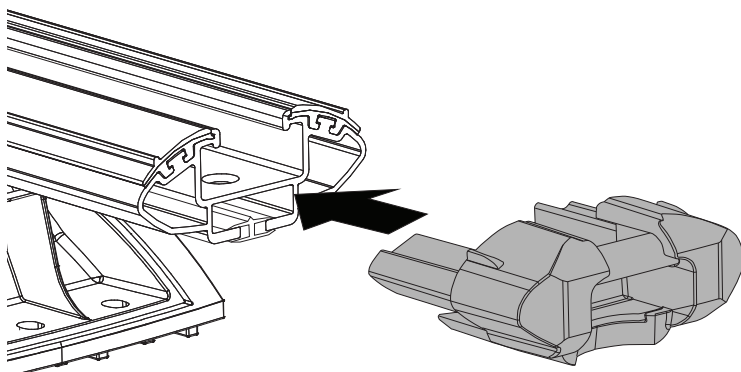

18 Secure using Plastite Screw (from LOCKN'LOAD Leg kit). Tighten using a #2 Phillips Head Screwdriver.

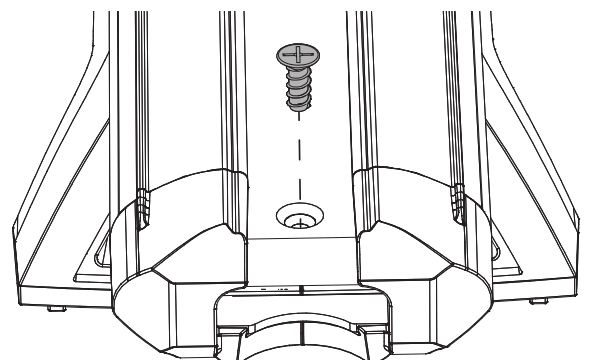

19 BAR FITMENT

Carefully place Bar assembly over Pads. **Take care not to damage vehicle.** Once positioned, locate the raised notches on base of Legs into the recesses on Pads. Repeat for all Bars.

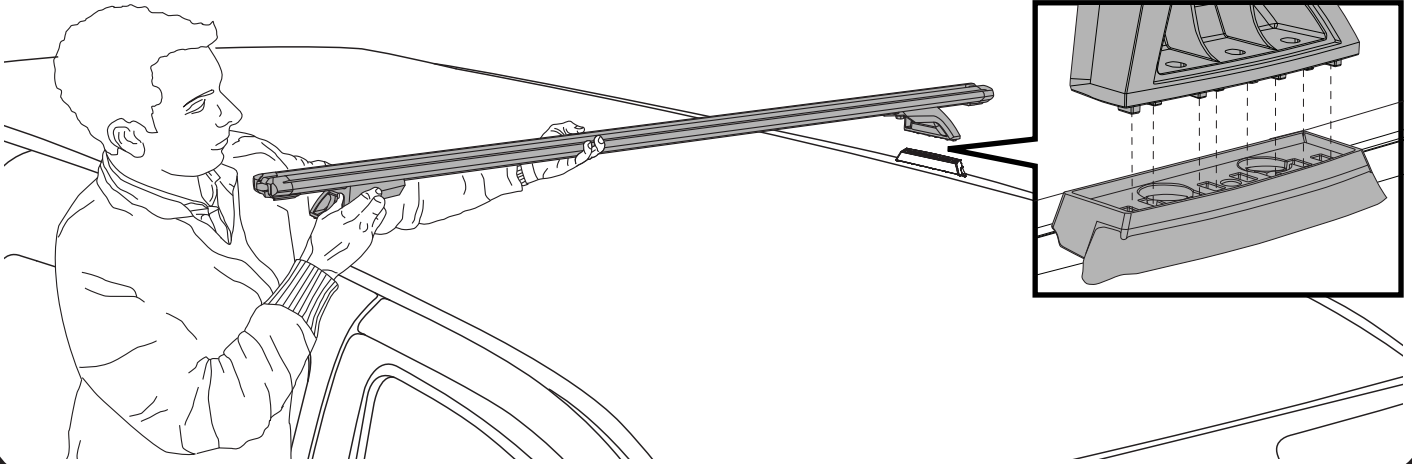

20 SECURE BARS TO PADS

From the LOCKN'LOAD Mounting kit, assemble 1 x M6 Washer onto each M6 set screw 30mm as shown. Insert through the centre hole on leg into Pad.

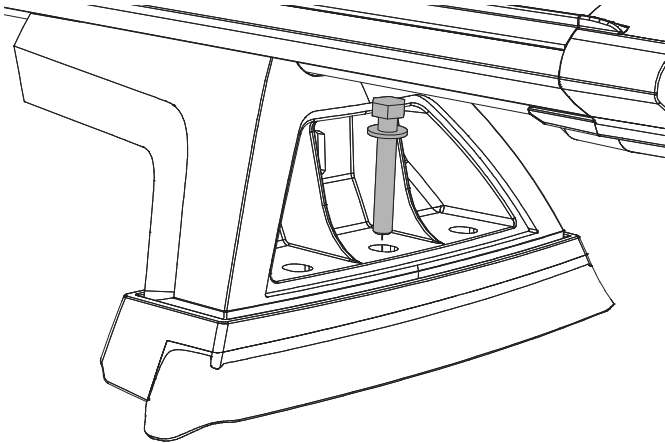

21 Tighten all M6 set screws to 7Nm using 10mm Socket Wrench.

Do not over tighten.

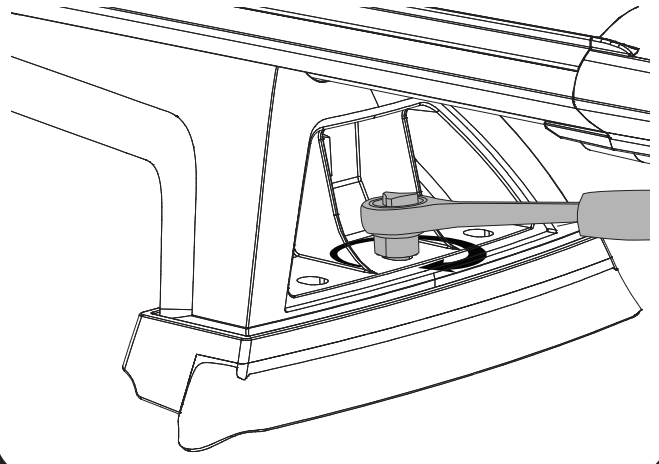

22 CHECK BAR LEGS ARE SECURE

Check all Bar Legs are secure.

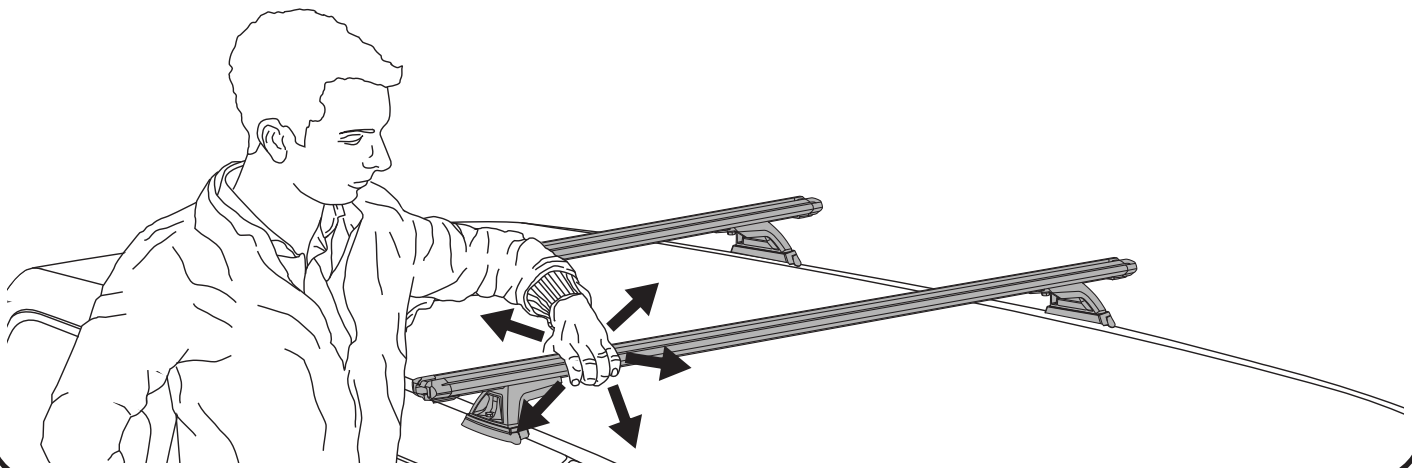

23**FIT LEG COVERS**

Using the keys and Covers supplied in the LOCKN'LOAD Leg Kit, fit and lock all Leg Covers.

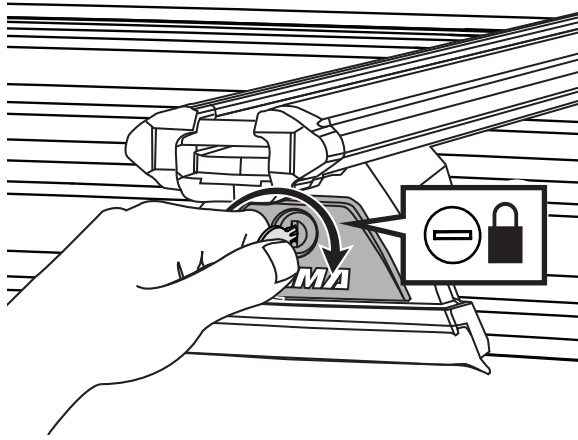
**24****BAR KEYS**

Place one key on the vehicle key ring and put the other away safely, or store with the spare vehicle key.

Write the key number (which is stamped on the key) in the box provided. Replacement keys are available from Yakima stockists, visit www.yakima.com.au or www.yakima.co.nz to find your nearest store or contact us directly on 1800 143 548 (AU) or 0800 4776 722 (NZ).

Key Number:
