

Kit 1021

MAZDA 626, 4-dr Sedan, 88-91

MAZDA 626, 5-dr Hatchback, 88-91

480R
754

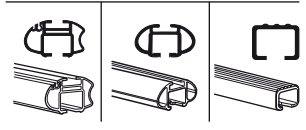
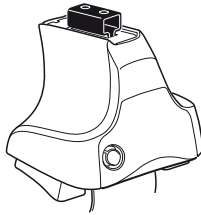

480

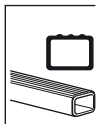
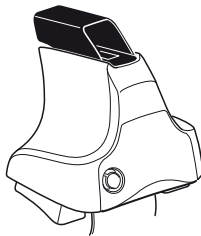

750

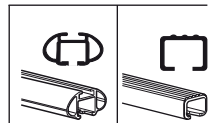
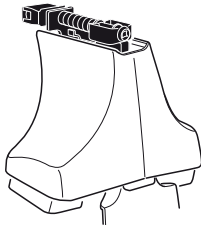

x2	x2	x2	x2	x2
x2		x2	x2	
x2		x4	x4	
x4				

Kit



3

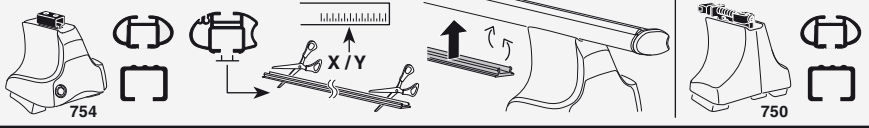

1

2

	X
MAZDA 626, 4-dr Sedan, 88-91	33,5
MAZDA 626, 5-dr Hatchback, 88-91	31

1

2

	Y
MAZDA 626, 4-dr Sedan, 88-91	30,5
MAZDA 626, 5-dr Hatchback, 88-91	29,5

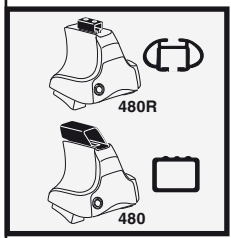

1

2

	X inch	X mm
MAZDA 626, 4-dr Sedan, 88-91	38 ⁷ / ₈ "	986 mm
MAZDA 626, 5-dr Hatchback, 88-91	37 ⁷ / ₈ "	961 mm

1

2

	Y inch	Y mm
MAZDA 626, 4-dr Sedan, 88-91	37 ⁵ / ₈ "	956 mm
MAZDA 626, 5-dr Hatchback, 88-91	37 ¹ / ₄ "	946 mm

4

MAZDA 626, 4-dr Sedan, 88-91

MAZDA 626, 5-dr Hatchback, 88-91

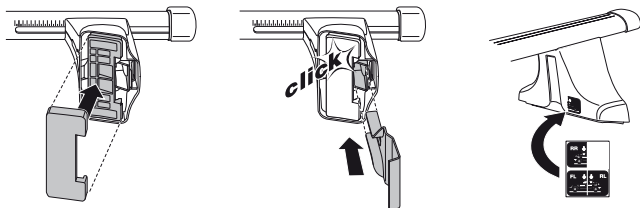
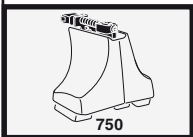
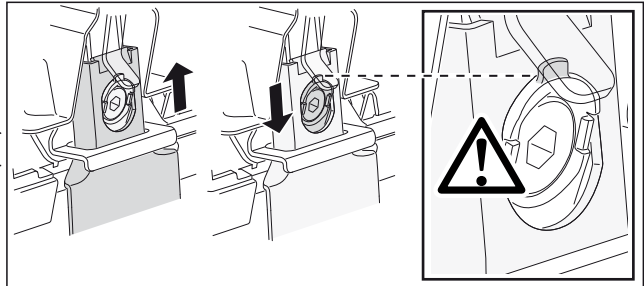
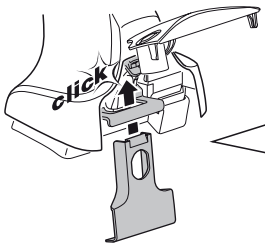
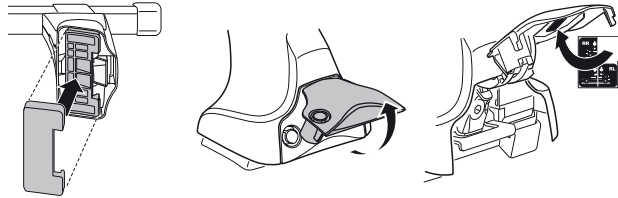
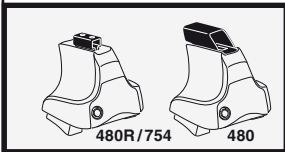
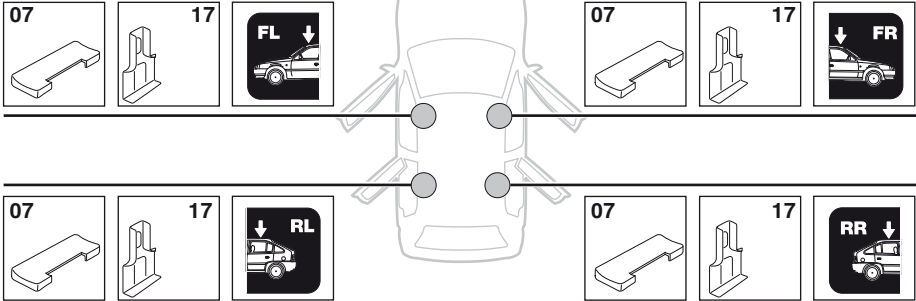

5



	X mm	Y mm	X inch	Y inch
MAZDA 626, 4-dr Sedan, 88-91	180 mm	700 mm	7 1/8"	27 1/2"
MAZDA 626, 5-dr Hatchback, 88-91	190 mm	700 mm	7 1/2"	27 1/2"

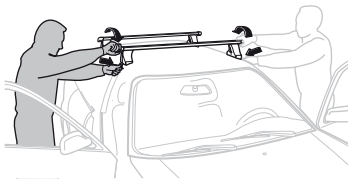
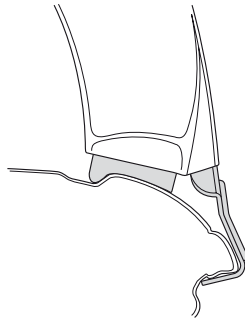
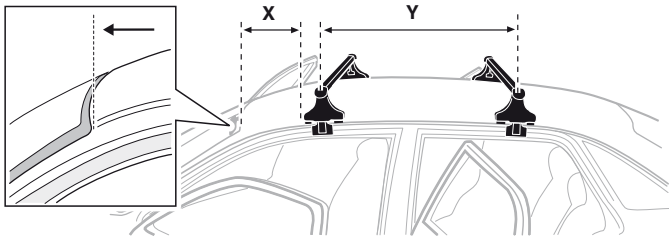

- GB/US** Tighten alternately
D Die Schrauben abwechselnd anziehen
F Serrer alternativement chaque côté
NL Afwisselend aan de linker- en de rechterkant aandraaien
I Alternare il serraggio delle viti
E Apretar alternativamente
PT Aperte alternadamente
S Dra åt växelvis

- FIN** Kierrä vuorotellen
EST Pinguldage vaheldumisi
LAT Pievelciet pamišus
LIT Užsukinėkite pakaitomis
PL Śruby dokręcaj naprzemiennie
RU Затягивайте попеременно
CZ Pokręťta багаžnika dokręcaj dokręcaj naprzemiennie.
SK Doťahujte striedavo
SLO Privijajte izmenično.
HR Naizmjenično zategnite
HU Egymástól fűggetlenül szorítandó
GR Σφιγγετε εναλλάξ
TR Dönüşümlü sıkın
中文 交替拧紧
한국어 번갈아 가며 조이십시오.
日本語 交互に締め付けてください。
ไทย ชันในแบบสลับ

6



480R/754



480

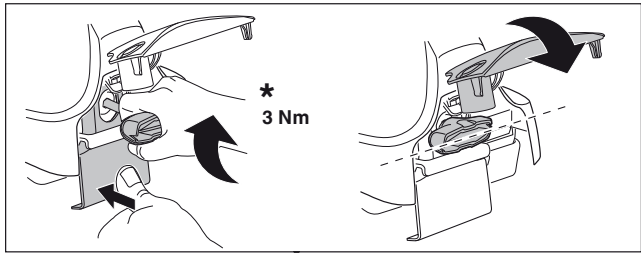
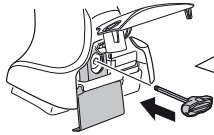

*
3 Nm



*



*
≈ 3 Nm

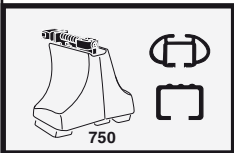
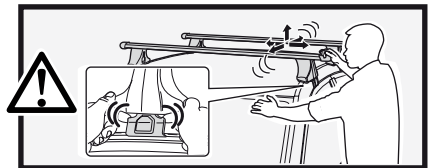

750

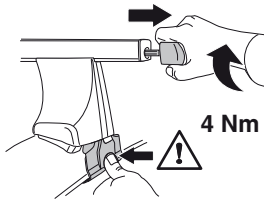

4 Nm

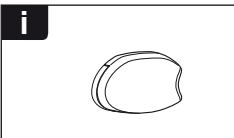
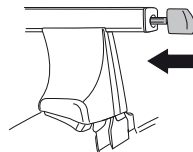

i

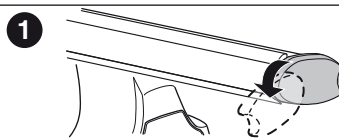

1

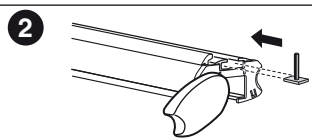

2

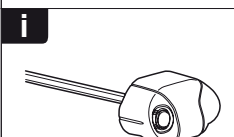

i

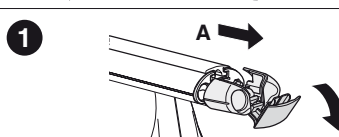

1

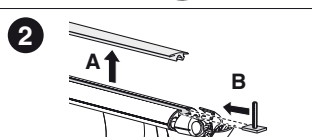

2

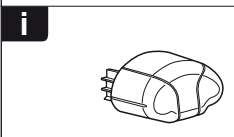

i

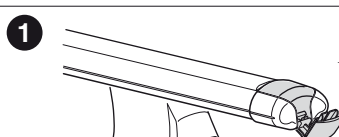

1

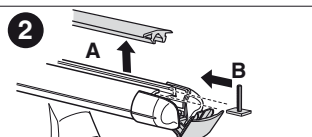

2



THULE
SWEDEN
**ONE
KEY
SYSTEM**



- 544 (x4)
- 596 (x6)
- 588 (x8)
- NA 510 (x10)
- EUR 452 (x12)
- ASIA 452 (x12)



WW ▶ Thule Sweden AB, Box 69, 330 33 Hillerstorp, SWEDEN
NA ▶ Thule Inc., 42 Silvermine Road, Seymour, Connecticut 06483, USA

info@thule.com
customer.service@thule.com

www.thule.com