



TOWBAR INSTALLATION INSTRUCTIONS

PART NUMBER 03384RW

KIA CARNIVAL KA4 CL4



PRODUCT DETAILS:

Part Number:	03384RW	Maximum Towing Braked:	2000	kg
ECU Number:	04826	Maximum Towing Unbraked:	750	kg
Tail Harness Length Required:	1200mm	Maximum Static Ball Load:	200	kg
TBM/Lug Part Number:	21126			
Wiring Part Number:	102056-WL			

FITTING DETAILS:

Towbar Installation Time:	60 Mins.	Hayman Reese SmartCODE Solution Required:	NO
Wiring Installation Time:	30 Mins.	RPA Disable/Other:	NO
Total Installation Time:	90 Mins.		
Bumper Cut Required:	Yes		

Note:

- RPA Disable: Switch near transmission lever
- Electric Brake Input Location: Near Pre-Wire Connector



TOWBAR INSTALLATION INSTRUCTIONS

PART NUMBER 03384RW

KIA CARNIVAL KA4 CL4

ENSURE THAT INSTRUCTIONS ARE UNDERSTOOD PRIOR TO FITMENT.

i BEFORE YOU START:

Hayman Reese recommends that instructions are read completely prior to fitment. Check all hardware items have been included refer to assembly diagram. Please ensure this towbar is only fitted to vehicle models as per Hayman Reese application guide (www.haymanreese.com.au).

Bumper Cuts



Vehicle and bumper variations can and do occur during vehicle manufacture after initial towbar design. Fitment of towbar to vehicle and accuracy of bumper cut must be assessed prior to any bumper modifications made. Incorrect bumper cuts are not covered under Hayman Reese warranty.

NOTE: Bumper cuts need to be approached with care, refer to notes below.

- Bumper centreline – where the centreline of the bumper needs to be determined, the installer must assess centre point by measurement of bumper width or determining two symmetrical reference points to give centreline.
- Bumper edge – To assist with accurate bumper cut measurement, reference to the start of the bumper edge is now being commonly used.
 - Measure from bottom edge along bumper and around corner to the 70 mm point (Figure 1).
 - Do not measure from visible bumper front of corner, upwards (Figure 2).

CORRECT

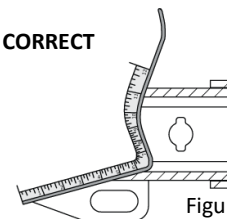

Figure 1

INCORRECT

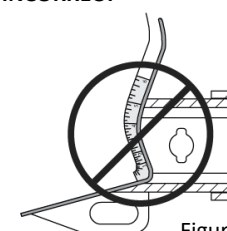

Figure 2

Drilling

- For any required drilling during installation, ensure that the area is clear of fuel, electrical & other components that may be damaged.
- All holes drilled into the body panels shall have all burrs & swarf removed then coated with a suitable rust preventative paint.

Bolts/Fasteners

- Ensure that all hardware is fastened to correct torque as specified in this fitting instruction.
- All fasteners supplied with this product are used to achieve a specified clamp loading. If replacement is required ensure that fasteners of the same grade and class are used.



NOTE: Achieving correct torque is critical to proper installation and responsibility of the installer. Towbar failures attributed to tension issues from over tightening or under tightening are not covered by Hayman Reese warranty.

Product Labels

- a. Towbar load rating sticker provided with this product shall be conspicuously located on inside rear end of the driver's door.
- b. Powertrain Control Module (PCM)/Body Control Module (BCM) upgrade warning label will be provided in towbar kit for vehicles as required. Affix warning label in door and owner's handbook.

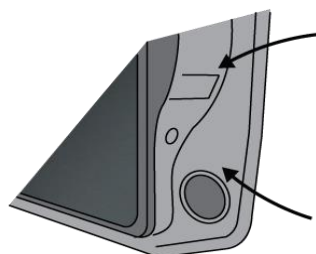

Place **Load Rating sticker** inside driver's door here

Place **Vehicle PCM/ BCM upgrade warning label** in door AND on front cover of owner's service handbook

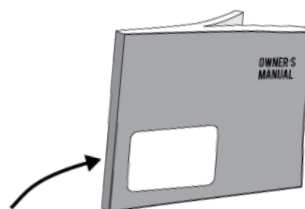

WARNING:

Do not, drill, cut, weld or otherwise modify the towbar.

FOR TOWING PURPOSES ONLY - This towbar is designed and tested by Hayman Reese to adhere to ADR 62/02 which provides only for the expected load demands of towing.



TOWBAR INSTALLATION INSTRUCTIONS

PART NUMBER 03384RW

KIA CARNIVAL KA4 CL4

i TOWBAR ASSEMBLY DIAGRAM

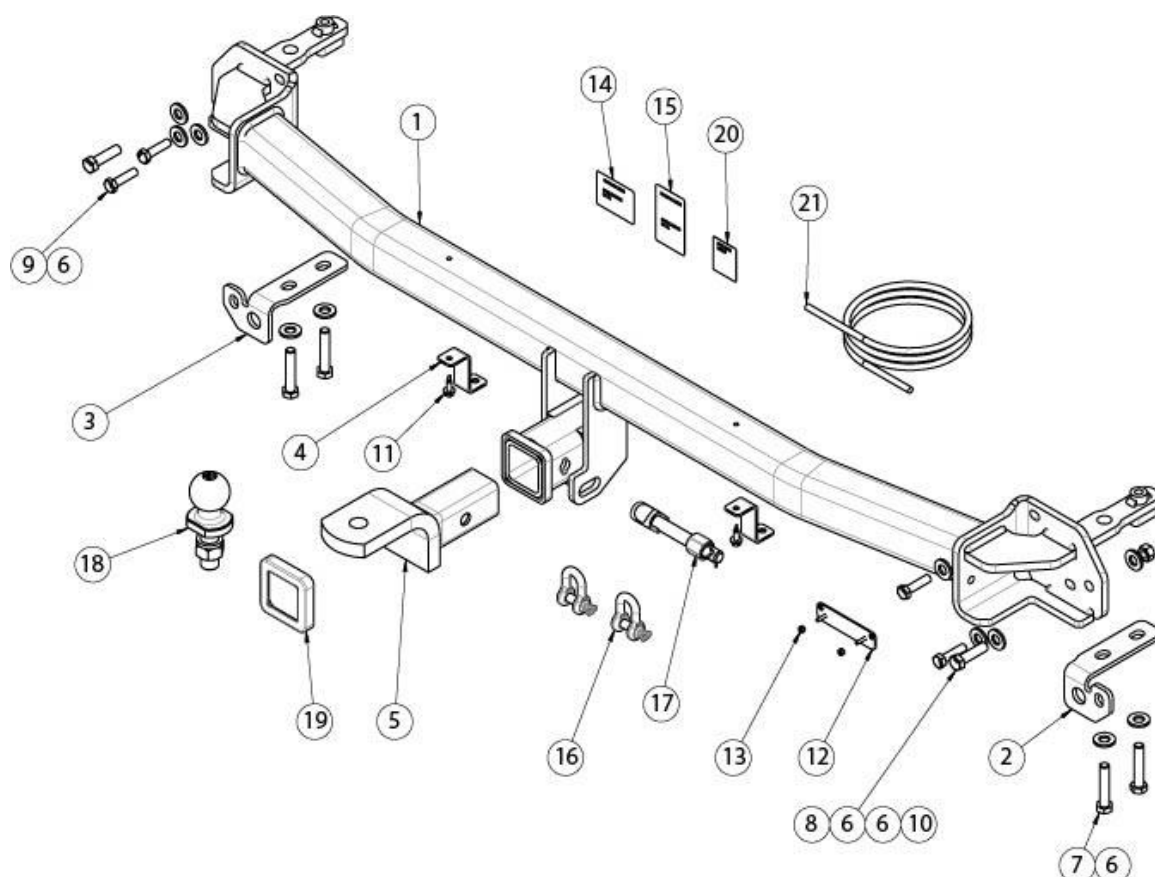

ITEM	DESCRIPTION	QTY
1	KIA CARNIVAL WELDED ASSEMBLY	1
2	SUPPORT PLATE RHS	1
3	SUPPORT PLATE LHS	1
4	BUMPER TAB	2
5	TRAILER BALL MOUNT	1
6	WASHER PLAIN 1/2"	12
7	BOLT HEX M12x60x1.25P	4
8	SET SCREW HEX HD M12x45x1.25P	2
9	BOLT HEX HD M10x40x1.25P	4
10	NUT HEX HD M12x1.25P	2
11	TEK SCREW 14-20 HEX HD 22mm	2

ITEM	DESCRIPTION	QTY
12	PLUG BRACKET	1
13	NUT NYLOC HEX HD M4x0.7P	2
14	COMPLIANCE LABEL	1
15	DOOR RATING LABEL	1
16	"D" SHACKLE 10mm	2
17	SMART PIN GOLD	1
18	TOWBALL 50mm	1
19	HITCH BOX COLLAR COVER	1
20	HAYMAN REESE LOGO STICKER	1
21	WIRING LOOM	1



TOWBAR INSTALLATION INSTRUCTIONS

PART NUMBER 03384RW

KIA CARNIVAL KA4 CL4

1. Open tailgate and remove the taillight cover.
Remove the exposed 2 x screws.

Repeat for other side.

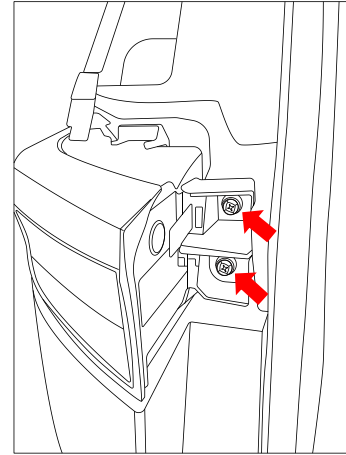

2. Remove the taillight, by pulling rearwards, and disconnect the plug.
3. Remove the exposed 1 x scrivet.

Repeat for other side.

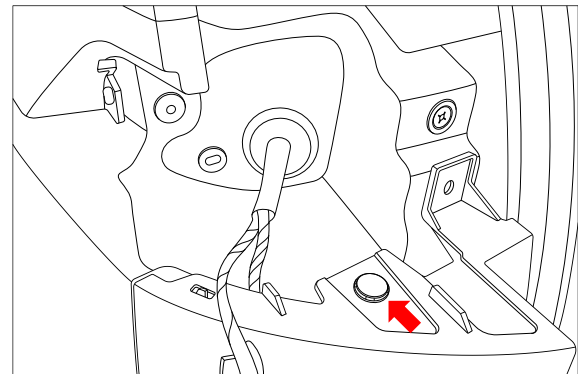

4. In wheel arch remove 4 x screws and 1 x plastic screw from the underside of bumper.

Repeat for other side.

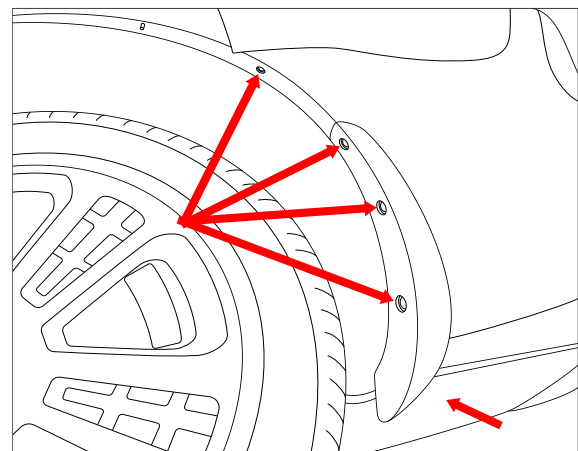

5. Under vehicle on passenger side, remove the plastic cover secured with 7 x clips.
6. Remove 4 x plastic clips along the bumper.
7. Peel away from the edge and carefully remove bumper, ensuring to disconnect the electrical plug.

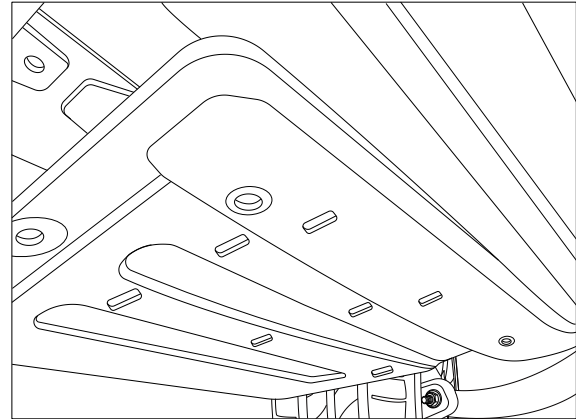

8. Remove and discard impact beam secured with 2 x bolts per side.

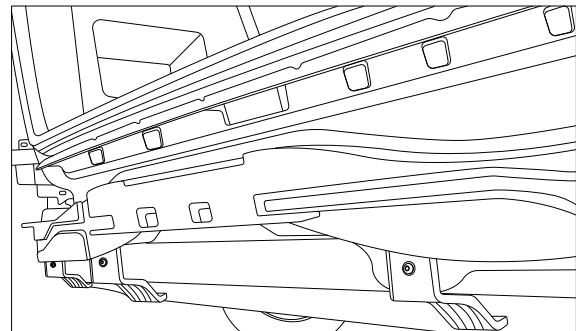

9. In the luggage compartment, fold both rear seats up (1).
10. Remove the rear scuff trim (2) by removing the 2 screws on each side (3), and then by lifting.
11. Fold the LHS seat flat.

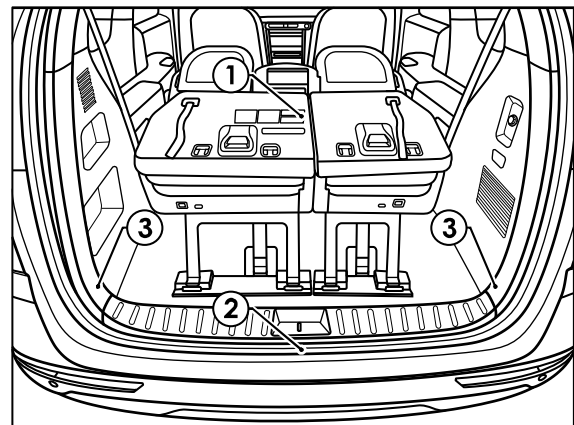

12. On the LHS, remove the upper D pillar trim (1).
13. Remove the rear LHS seatbelt bolt (2).
14. Remove the last 2 bolts (3) securing the LHS luggage compartment trim (4).

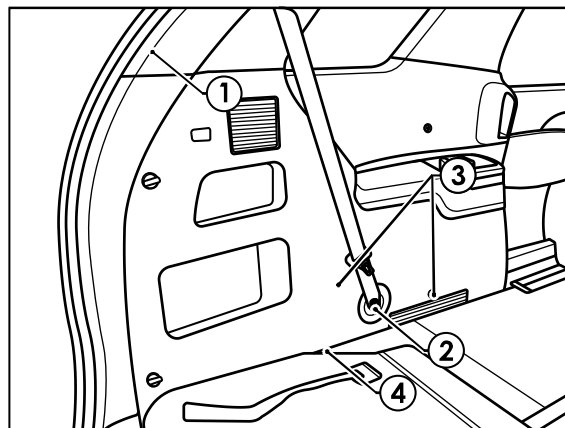

15. Position the towbar onto vehicle with the sidearms going into the chassis rail. Loosely secure each side to the back panel captive nuts with 2 x M10 bolts complete with 1 x washer per bolt.

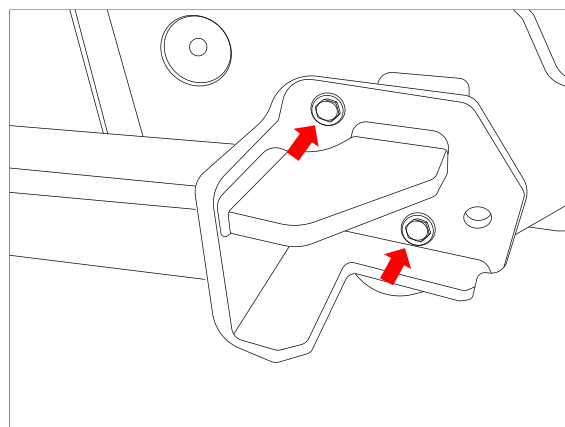

16. Position the support plate under the chassis rail and loosely secure with 2 x M12 bolts complete with 1 x washer per bolt and to the back panel with 1 x M12 bolt complete with 2 x washers and 1 x nut per bolt.

Repeat for other side.

Tighten all fasteners to the following torque:

- M10 x 1.25 Gr 10.9 : 68Nm**
- M12 x 1.25 Gr 10.9 : 125Nm**

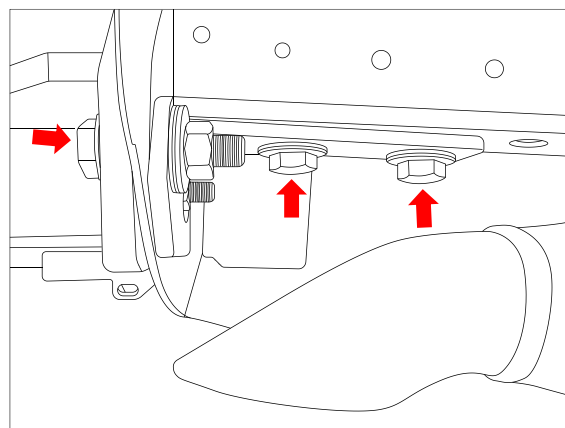

17. Fit the bumper tabs to the crosstube with 1 x tek screw. Ensure to not overtighten.

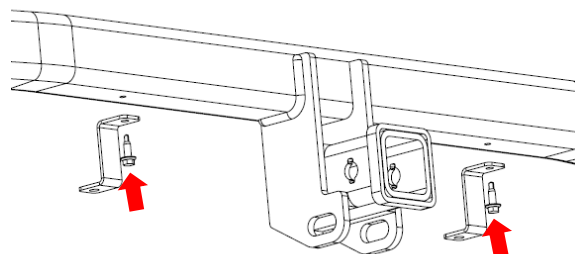

18. For Bumper cut.

Determine the centre of the bumper, measure, mark off and cut out 90mm wide and 140mm long, measured from the bottom edge of the bumper.

Ensure to not cut through or damage any cables located on the inside of the bumper.

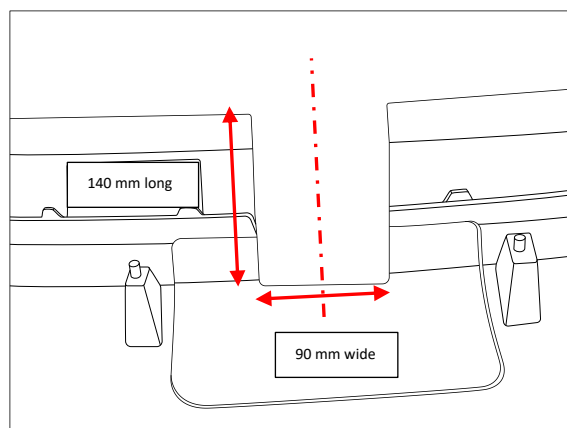

19. For plug bracket.

At an appropriate position on the bumper, mark out and drill 2x \varnothing 5mm holes 69mm apart on bumper skin to support plug bracket.

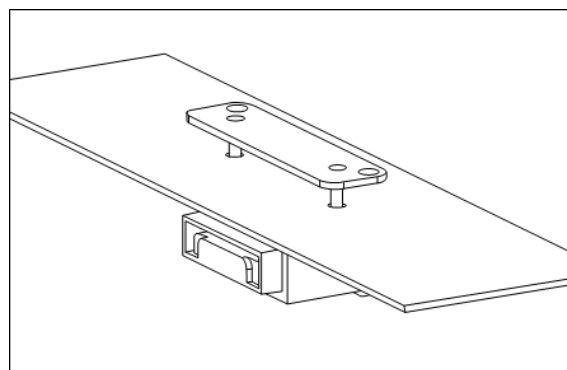

20. Fold the LHS luggage compartment trim inwards to gain access to the trailer lights prewire connector.
21. Locate the trailer lights prewire connector (1) and connect to the mating connector on the patch harness (2).
22. Connect the ground wire to the vehicle earthing point (3).
23. Use the supplied cable ties to bundle and secure the excess length to the existing vehicle harness.

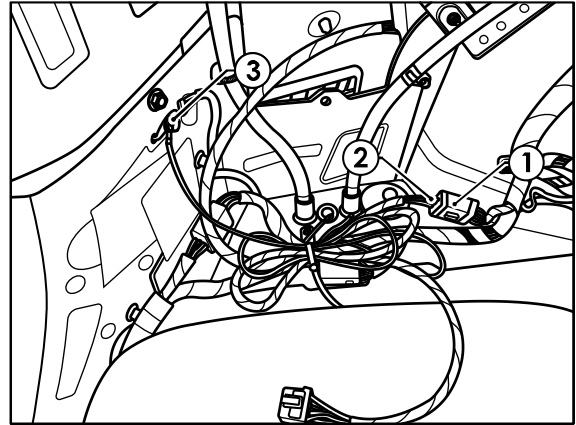

24. Using an alcohol wipe, clean the LHS inner sheet metal area (1) and the underside of the ECU (04826) (2).
 25. Connect the trailer patch 12-way connector (3) to the ECU.
 26. Apply double sided tape to the ECU (2) and secure it to the vehicle sheet metal.
- Note: Mount the ECU, ensuring the connector is orientated downwards.**

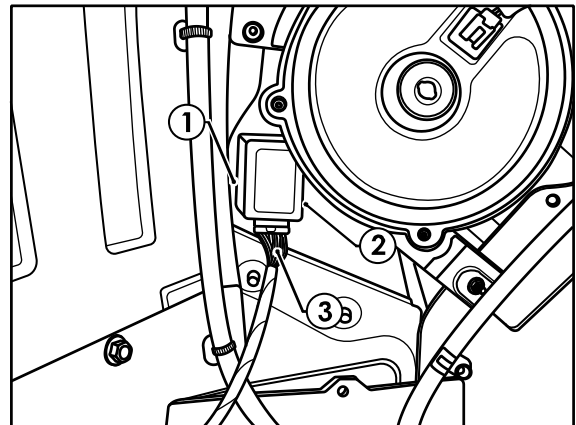

27. Drill a 30mm grommet hole (1) in a suitable location to enable the tail harness to be routed from the towbar to the ECU.

Note: File any sharp edges and spray with rust inhibitor.

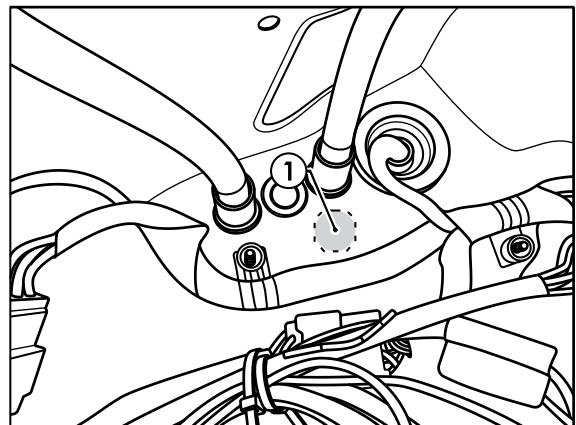



TOWBAR INSTALLATION INSTRUCTIONS

PART NUMBER 03384RW

KIA CARNIVAL KA4 CL4

28. With the rear bumper removed, secure tail harness to towbar
29. Route tail harness up through chassis and previously drilled 30mm hole.
30. Seat grommet in 30mm hole and route to trailer harness blue connector on patch loom.

Note: Keep harness routing clear of all sharp edges, moving parts and places of extreme heat.

Note: Ensure grommet is seated correctly and makes a good seal.

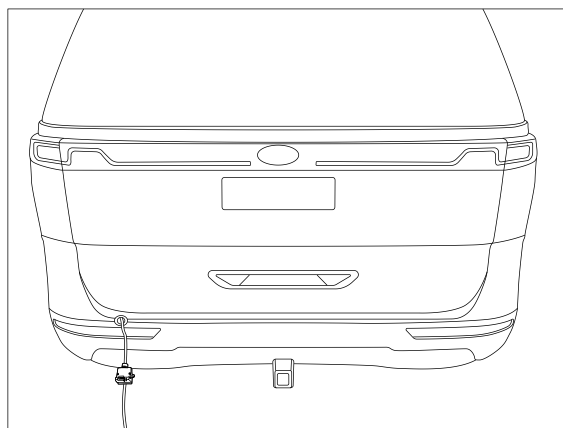

31. Connect the tail harness (tail length 1200mm) 8-way connector to the trailer patch mating 8-way connector.
32. Secure all harness using supplied cable ties.
33. Test the trailer patch function using a light board or multi-meter.
34. Re-fit all removed parts and secure all fasteners, ensuring there are no squeaks or rattles from step 1 to 14 in reverse.
35. The RPA function can be disabled via a switch (1) next to the gear shifter.
36. Place the fitting instructions in the glove box after fitment.

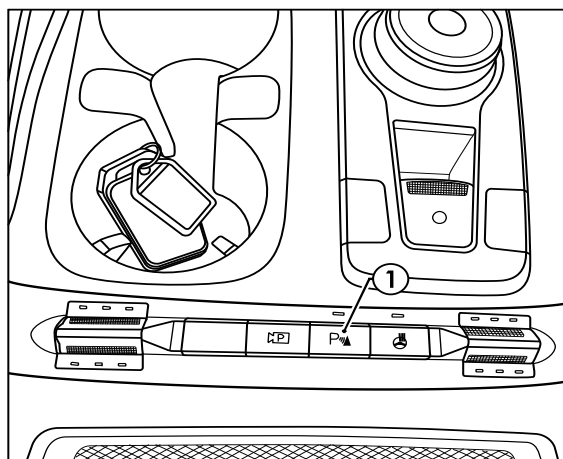



CUSTOMER INFORMATION

PLACE THESE INSTRUCTIONS IN THE
VEHICLE'S GLOVEBOX AFTER INSTALLATION

**THANK YOU FOR PURCHASING HAYMAN REESE.
WITH CORRECT MAINTENANCE AND CARE THIS PRODUCT WILL PROVIDE A
LIFETIME OF TROUBLE-FREE OPERATION.**

i TOWBAR MAINTENANCE AND CARE:

1. Hayman Reese recommend that the towbar LUG or TBM (tow ball Mount) Pull Pin and R-clip are removed and stored when not in use. Removal of LUG or TBM (tow ball mount) is advisable when not in use to assist with any of the following.
 - Ensure rear number plate is not obscured.
 - Allow maximum available departure angle and prevent any potential interference.
 - Prevent possible interference with vehicles reverse sensors or camera detecting a tow ball mount as an obstruction during reversing.
 - Removes towball mount as an obstruction for when moving around the rear of the vehicle.
2. Hayman Reese recommends routine inspection of your towbar to ensure trouble free towing.
 - Bolt security and tension should be regularly inspected and checked for correct tension. Replace any worn or defective parts with suitable grade & class fasteners. Inspection should be requested to coincide with vehicle major services.
3. It is the owner's responsibility to ensure towing and down ball weight capacities of the towing vehicle are not exceeded.
 - Towing and down ball weights allowable may differ according to model variations. Please refer to owner's manual or vehicle dealer to confirm exact rating for your vehicle model variant.
 - It is not uncommon for the vehicle tow rating to differ from the towbar rating. When this occurs, the lesser rating must be adhered to.
 - For vehicles fitted with enhanced vehicle functions that may be altered/changed when towing i.e Trailer sway mitigation, blind spot detection, adaptive cruise control etc. Please consult owner's manual to understand changes enabled when towing and after towing.

i WARRANTY INFORMATION:

Hayman Reese Towbars are covered by a Lifetime Warranty.

Our goods come with guarantees that cannot be excluded under the Australian Consumer Law. You are entitled to a replacement or refund for a major failure and for compensation for any other reasonably foreseeable loss or damage. You are also entitled to have the goods repaired or replaced if the goods fail to be of acceptable quality and the failure does not amount to a major failure.

For further details please visit www.haymanreese.com.au/warranty or contact customer service on 1800 812 017 or info@haymanreese.com.au.



CUSTOMER INFORMATION

PLACE THESE INSTRUCTIONS IN THE VEHICLE'S GLOVEBOX AFTER INSTALLATION

HAYMAN REESE SMART PIN

Your Hayman Reese towbar is equipped with Smart Pin technology to help reduce towbar tongue rattle in most driving conditions. Please ensure below instructions are understood and routine maintenance is carried out to ensure best towing experience.

i Regularly inspect for wear and check the tightness of the Smart Pin Nut. Follow instructions below to re-tighten the nut as necessary when movement and noise in the tow ball mount is noted.

- Before towing, ensure R-Clip is properly installed and Smart pin nut is installed and tensioned. Replacement parts are available from your Hayman Reese Distributor.

TOWBALL MOUNT REMOVAL/INSTALLATION

STEP 1

Insert Trailer Ball Mount (TBM) (a) into towbar hitchbox (b), aligning hole in TBM shank (c) with hole in hitchbox (d) (Fig. 1)

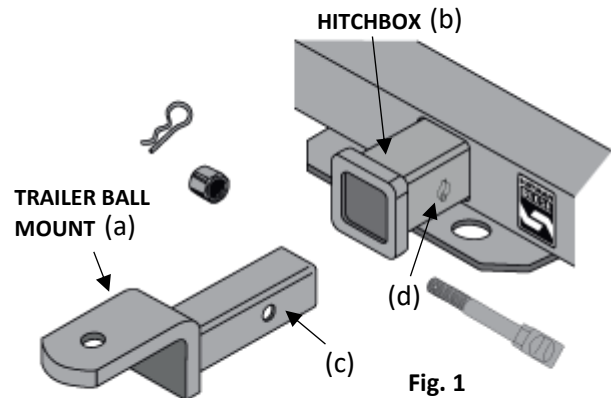

STEP 2

Insert Smart Pin (e) through hole in hitchbox and hole in TBM shank (g); ensure the locators are inserted into the notches in the hitchbox (Fig. 2)

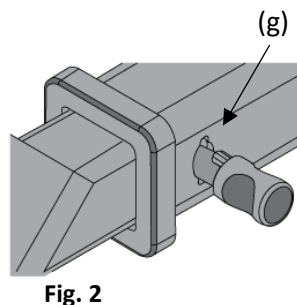

STEP 3

Screw Smart Pin Nut (f) onto Smart Pin (g); tighten Smart Pin Nut until finger tight, ensuring TBM is restrained from up and down movement.

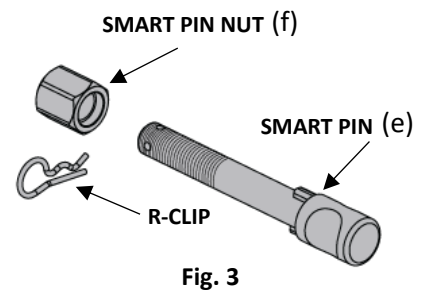

STEP 4

Tighten Smart Pin Nut by turning nut a further 1/8th of a turn in the clockwise direction using a 24mm spanner (Fig. 4).

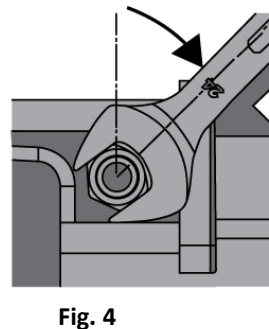

STEP 5

Install Smart Pin R-Clip through the hole that provides best clearance or easiest access. (Fig. 5)

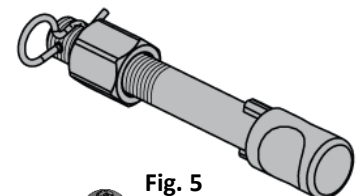

STEP 6

Install towball onto TBM and tighten to **350 Nm** using a calibrated torque wrench (Fig. 6).

