



TOWBAR INSTALLATION INSTRUCTIONS

PART NUMBER 03372RW

HYUNDAI SANTA FE TM3 CL4



PRODUCT DETAILS:

Part Number:	03372RW	Maximum Towing Braked:	2000	kg
ECU Number:	04826	Maximum Towing Unbraked:	750	kg
Tail Harness Length Required:	1200 mm	Maximum Static Ball Load:	200	kg
TBM/Lug Part Number:	21325			
Wiring Part Number:	102056-WL			

FITTING DETAILS:

Towbar Installation Time:	90 Mins.	Hayman Reese SmartCODE Solution Required:	NO
Wiring Installation Time:	60 Mins.	RPA Disable/Other:	NO
Total Installation Time:	150 Mins.		
Bumper Cut Required:	Yes		

Note:

- RPA Disable: Near transmission lever
- Electric brake input location: Near pre-wire connector



TOWBAR INSTALLATION INSTRUCTIONS

PART NUMBER 03372RW

HYUNDAI SANTA FE TM3 CL4

ENSURE THAT INSTRUCTIONS ARE UNDERSTOOD PRIOR TO FITMENT.

i BEFORE YOU START:

Hayman Reese recommends that instructions are read completely prior to fitment. Check all hardware items have been included refer to assembly diagram. Please ensure this towbar is only fitted to vehicle models as per Hayman Reese application guide (www.haymanreese.com.au).

Bumper Cuts



Vehicle and bumper variations can and do occur during vehicle manufacture after initial towbar design. Fitment of towbar to vehicle and accuracy of bumper cut must be assessed prior to any bumper modifications made. Incorrect bumper cuts are not covered under Hayman Reese warranty.

NOTE: Bumper cuts need to be approached with care, refer to notes below.

- Bumper centreline – where the centreline of the bumper needs to be determined, the installer must assess centre point by measurement of bumper width or determining two symmetrical reference points to give centreline.
- Bumper edge – To assist with accurate bumper cut measurement, reference to the start of the bumper edge is now being commonly used.
 - Measure from bottom edge along bumper and around corner to the 70 mm point (Figure 1).
 - Do not measure from visible bumper front of corner, upwards (Figure 2).

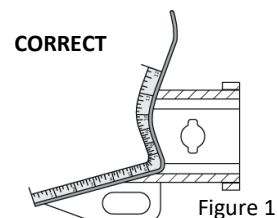

Figure 1

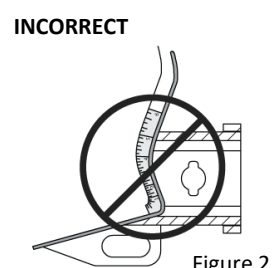

Figure 2

Drilling

- For any required drilling during installation, ensure that the area is clear of fuel, electrical & other components that may be damaged.
- All holes drilled into the body panels shall have all burrs & swarf removed then coated with a suitable rust preventative paint.

Bolts/Fasteners

- Ensure that all hardware is fastened to correct torque as specified in this fitting instruction.
- All fasteners supplied with this product are used to achieve a specified clamp loading. If replacement is required ensure that fasteners of the same grade and class are used.



NOTE: Achieving correct torque is critical to proper installation and responsibility of the installer. Towbar failures attributed to tension issues from over tightening or under tightening are not covered by Hayman Reese warranty.

Product Labels

- a. Towbar load rating sticker provided with this product shall be conspicuously located on inside rear end of the driver's door.
- b. Powertrain Control Module (PCM)/Body Control Module (BCM) upgrade warning label will be provided in towbar kit for vehicles as required. Affix warning label in door and owner's handbook.

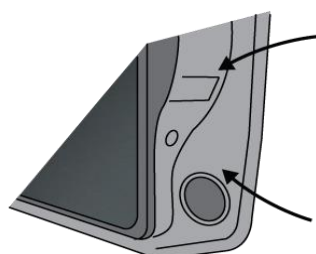

Place **Load Rating sticker** inside driver's door here

Place **Vehicle PCM/ BCM upgrade warning label** in door AND on front cover of owner's service handbook

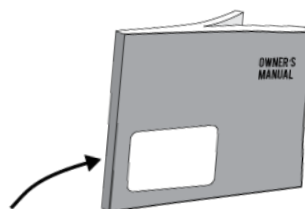

WARNING:

Do not, drill, cut, weld or otherwise modify the towbar.

FOR TOWING PURPOSES ONLY - This towbar is designed and tested by Hayman Reese to adhere to ADR 62/02 which provides only for the expected load demands of towing.



TOWBAR INSTALLATION INSTRUCTIONS

PART NUMBER 03372RW

HYUNDAI SANTA FE TM3 CL4

i TOWBAR ASSEMBLY DIAGRAM

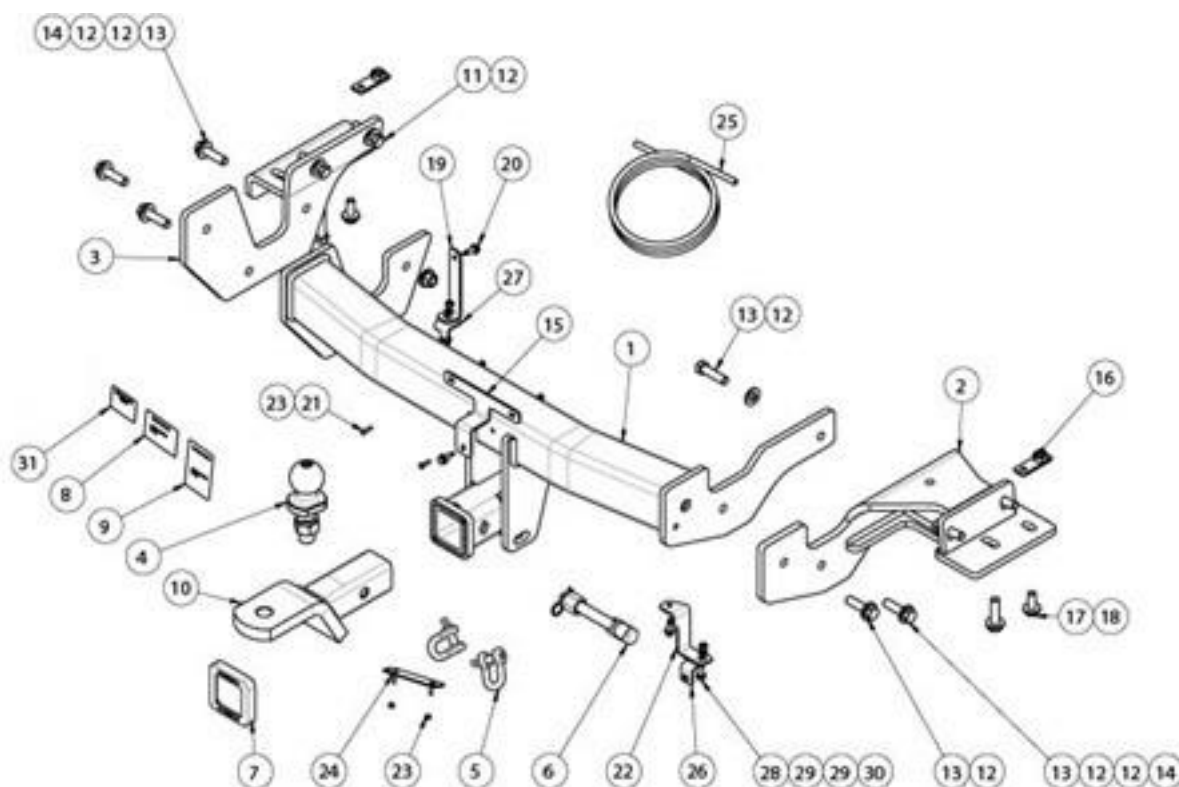

ITEM	DESCRIPTION	QTY
1	KIA SORENTO WELDED ASSY	1
2	SIDE ARM – RHS	1
3	SIDE ARM – LHS	1
4	TOWBALL 50mm	1
5	"D" SHACKLE 10mm	2
6	SMART PIN GOLD	1
7	HITCH BOX COLLAR COVER	1
8	COMPLIANCE LABEL	1
9	DOOR RATING LABEL	1
10	TRAILER BALL MOUNT	1
11	BOLT HEX HD M12x45x1.25P	6
12	WASHER PLAIN 1/2"	15
13	BOLT HEX HD M12x45x1.75P	6
14	NUT HEX HD M12x1.75P	3
15	SENSOR BRACKET	1
16	NUT PLATE	2

ITEM	DESCRIPTION	QTY
17	BOLT HEX HD M10x30x1.5P	2
18	WASHER PLAIN M10x25x3	2
19	BUMPER TAB – LHS	1
20	TEK SCREW 14-20 HEX HD 22mm	3
21	SCREW PAN HD M4x16x0.7P	2
22	BUMPER TAB RHS	1
23	NUT NYLOC HEX HD M4x0.7P	4
24	PLUG BRACKET	1
25	WIRE LOOM	1
26	LOWER BUMPER TAB 1	1
27	LOWER BUMPER TAB 2	1
28	SET SCREW HEX HD M6x16x1.0P	2
29	WASHER FLAT M6x12.5x1.2P	4
30	HEX NUT M6x1.0P	2
31	H.R STICKER	1



TOWBAR INSTALLATION INSTRUCTIONS

PART NUMBER 03372RW

HYUNDAI SANTA FE TM3 CL4

1. Open the tailgate.
Using the wheel tool kit and lower the spare wheel.

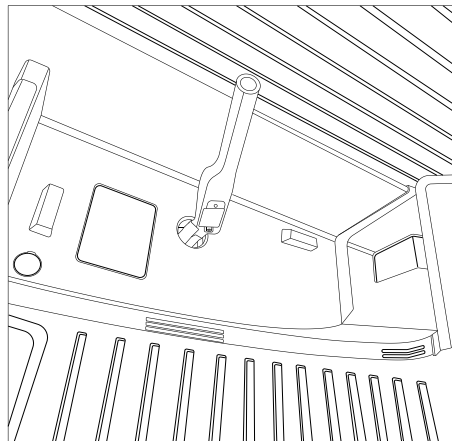

2. Remove 2x screws and pull the taillight rearward.

Repeat for the other side.

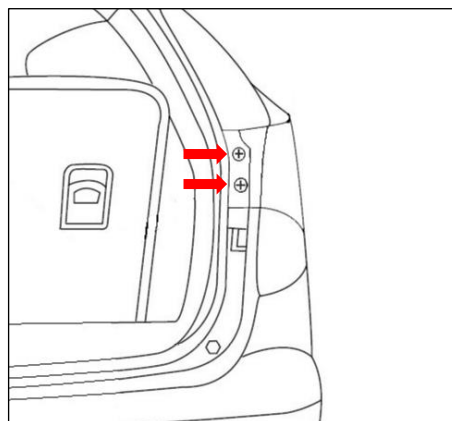

3. Remove 1x scrivet clips.

Repeat for the other side.

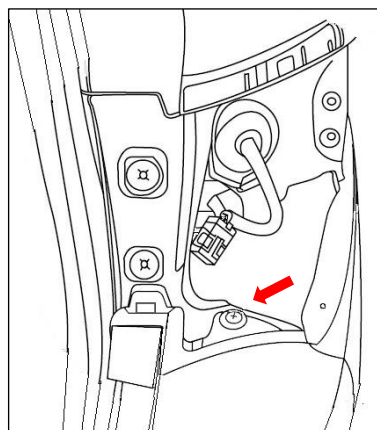



TOWBAR INSTALLATION INSTRUCTIONS

PART NUMBER 03372RW

HYUNDAI SANTA FE TM3 CL4

-
4. Remove 4x screws.

Repeat for the other side.

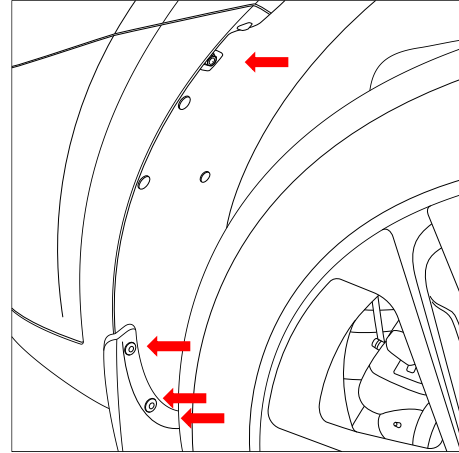

-
5. On the LHS below the wheel arch.
Remove 4x scrivet clips and 2x plastic nuts.

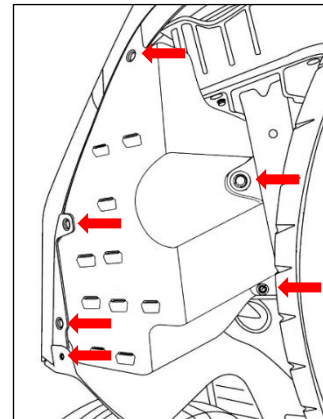

-
6. On the RHS below the wheel arch.
Remove 3x scrivet clips.

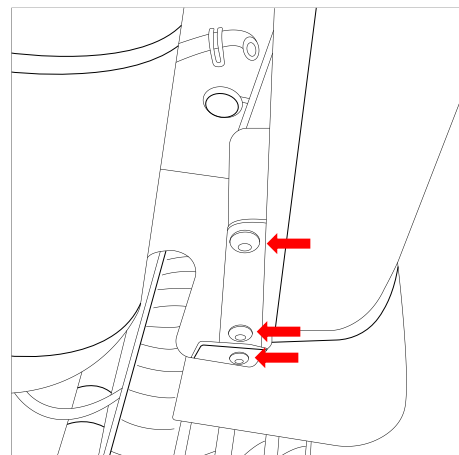



TOWBAR INSTALLATION INSTRUCTIONS

PART NUMBER 03372RW

HYUNDAI SANTA FE TM3 CL4

7. Remove 3x bolts from the impact beam which attached to the bumper.

Repeat for the other side.

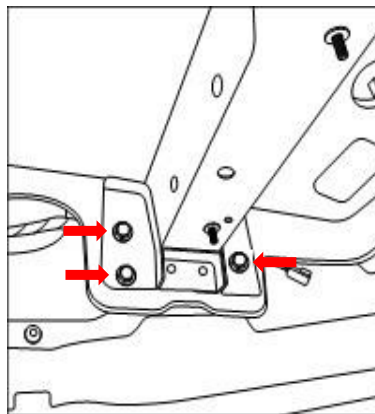

8. Unclip the bumper.

NOTE:

Disconnect the bumper sensor wire loom located on LHS of the bumper.

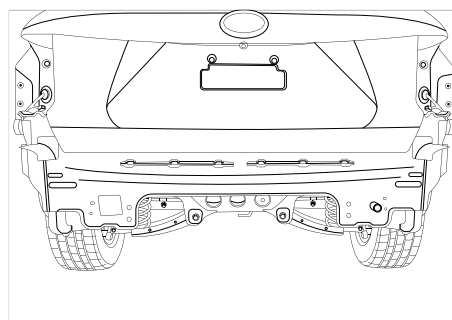

9. Remove the exhaust muffler by unscrew 2x bolts and slide off 3x rubber muffler hangers.

NOTE:

Leave the rubber hangers on the vehicle.

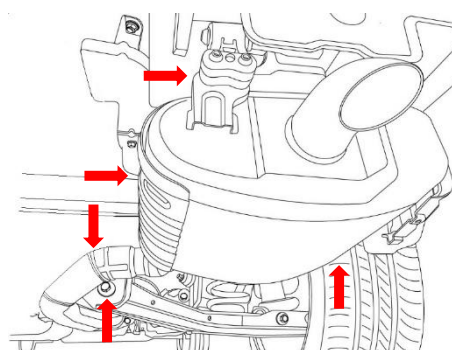



TOWBAR INSTALLATION INSTRUCTIONS

PART NUMBER 03372RW

HYUNDAI SANTA FE TM3 CL4

10. Remove the rubber grommet on the chassis.
Insert the nut plate into the hole.

Repeat for the other side.

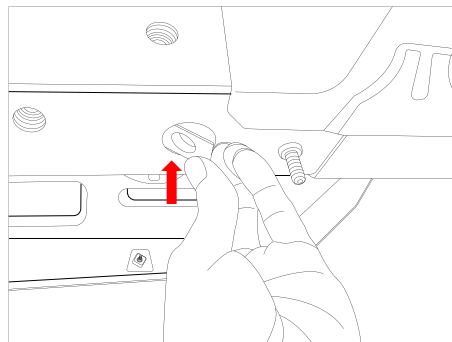

11. Fit the LHS side arm and loosely secure with 3x M12 bolts and 3x M12 washers.

Loosely secure with 1x M10 bolt and 1x M10 washer.

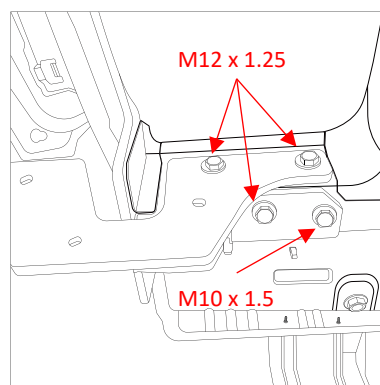

12. Fit the RHS side arm and loosely secure with 3x M12 bolts and 3x M12 washers.

Loosely secure with 1x M10 bolt and 1x M10 washer.

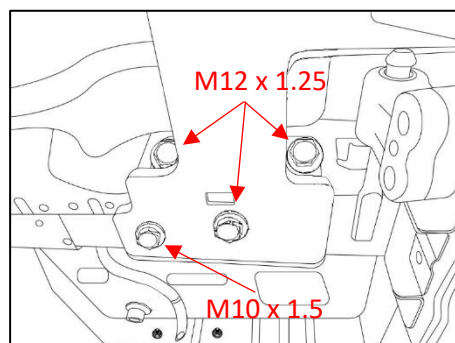



TOWBAR INSTALLATION INSTRUCTIONS

PART NUMBER 03372RW

HYUNDAI SANTA FE TM3 CL4

13. Fit the cross tube between the side arms.
Loosely secure with 3x bolts, 5x washers and 2x nuts.

Repeat for the other side.

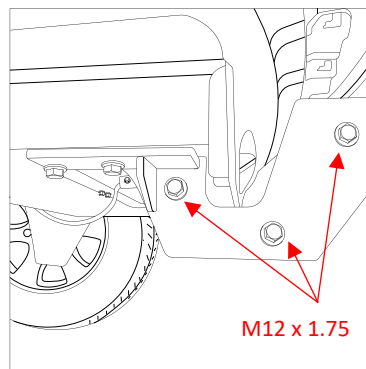

14. Torque all bolts:

Torque Spec:

M10 x 1.5 = 62 Nm

M12 x 1.25 = 125 Nm

M12 x 1.75 = 109 Nm

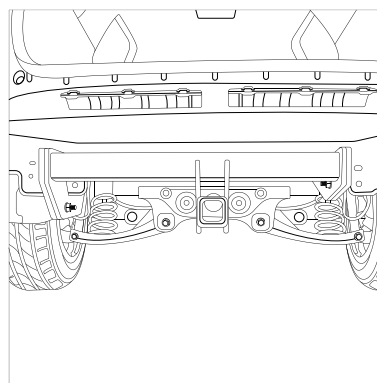

15. Remove the wire harness by cutting the wire fir tree clips on the impact beam.
Unclip 5x scrivets from the impact beam.
Remove 2x screws and disconnect the antenna.

Remove and discard the impact beam.

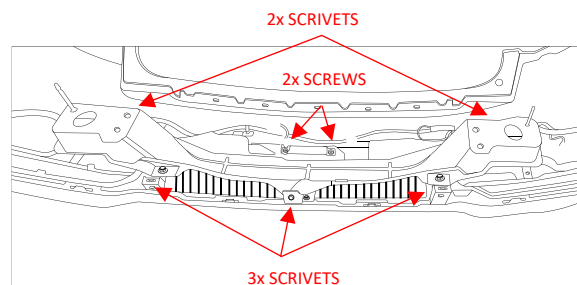



TOWBAR INSTALLATION INSTRUCTIONS

PART NUMBER 03372RW

HYUNDAI SANTA FE TM3 CL4

16. On LHS, secure the bumper tab bracket to the towbar using a Tek screw.

Secure the lower bracket with 1x M6 screw, 2x washers and 1x nut.

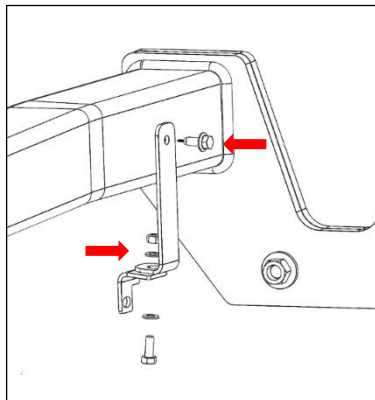

17. On RHS, secure the bumper tab bracket to the towbar using a Tek screw.

Secure the lower bracket with 1x M6 screw, 2x washers and 1x nut.

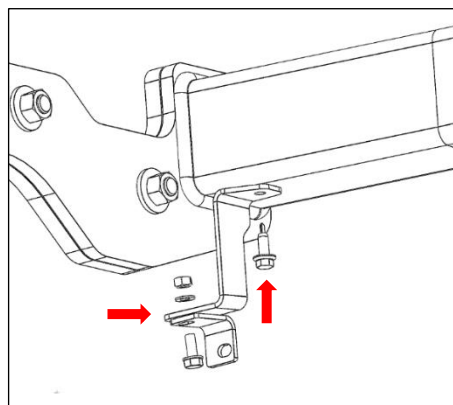

18. Secure the bracket to the towbar using a screw.
Secure the antenna to the bracket using 2x screws and 2x nuts.

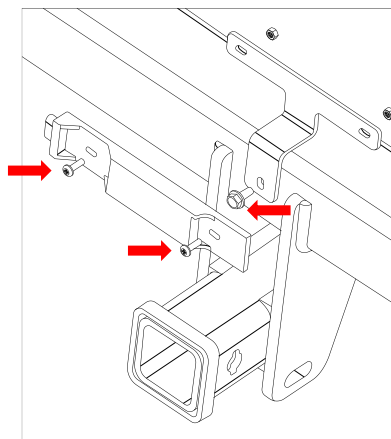



TOWBAR INSTALLATION INSTRUCTIONS

PART NUMBER 03372RW
HYUNDAI SANTA FE TM3 CL4

19. Cut out template on page 15.
Place template to the bumper outer skin.
Mark and cut out the area of the bumper.

Locate the plug bracket and ensure the harness cable length is long enough.
Drill 2x \varnothing 5mm holes 69mm apart.

Remove all swarf and rough edges.

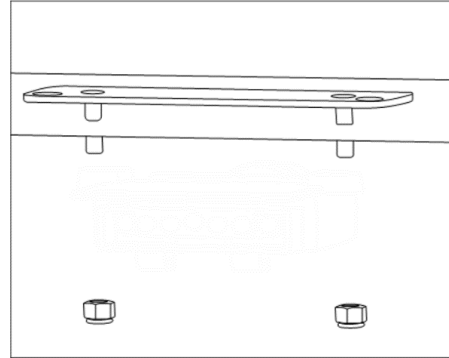

IMPORTANT

Due to possible vehicle variations, always confirm any noted vehicle colour wires with a multi-meter to ensure the correct function is identified before soldering or scotch locking. For vehicle wires denoted with two colours (example; RED/GREEN) the first colour will always be the main wire colour while the second colour is the thinner trace colour on the wire.

20. In the engine bay, disconnect the vehicle negative battery (1).

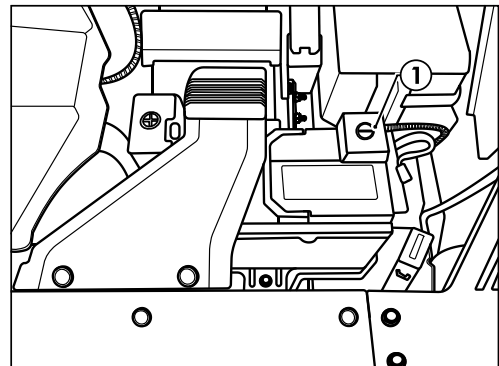



TOWBAR INSTALLATION INSTRUCTIONS

PART NUMBER 03372RW
HYUNDAI SANTA FE TM3 CL4

21. In the boot, fold down the rear seats (1).
22. Lift up the boot cover storage carpet lid (2).

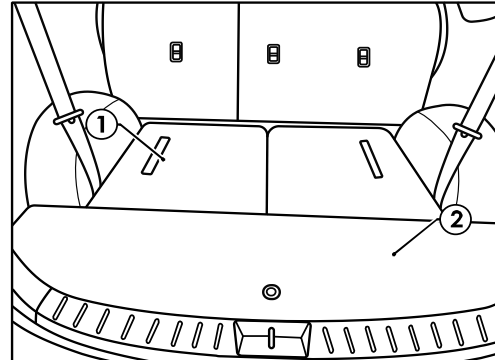

23. Remove the rear sunshade (1) and the foam jack storage tray.

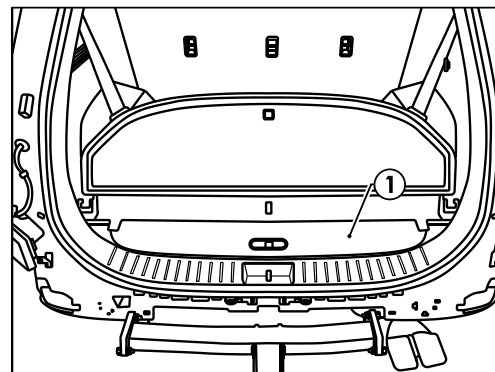

24. Using a flat blade screw driver, dislodge the 3 caps covering the screws (1) on the storage trim.
25. Using a 10mm socket or a Phillips head screw driver, remove the 3 screws (2) securing the rear floor trim (3).
26. Remove the entire storage trim (3) and carpet lid assembly from the vehicle by pulling in an upwards direction.

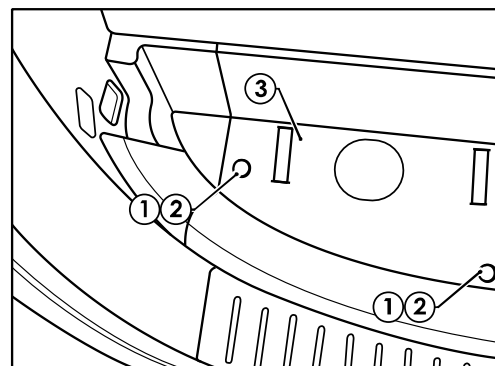

-
27. Remove the boot scuff plate (1) by pulling in an upwards direction.

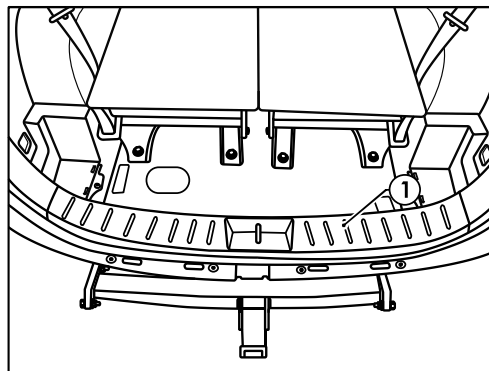

-
28. Using a 14mm socket, remove the 4 bolts (1) securing the LHS rear seat (2).
29. Disconnect the seat belt warning connector (3).
30. Remove the rear LHS seat (2).

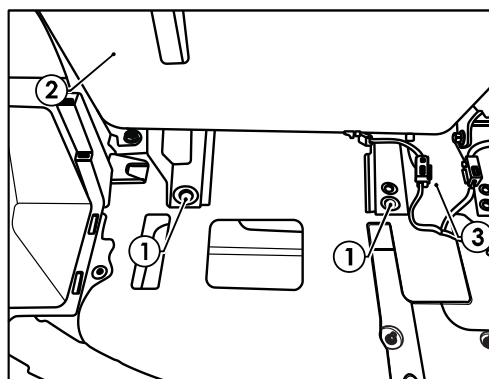

-
31. Remove the 3 screws securing the LHS trim (1).
32. Remove the screw behind the luggage mounting hook (2) by removing the cover.

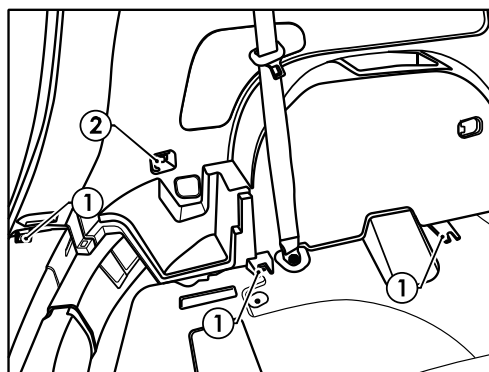

33. Fully dislodge the rear LHS trim to gain access to the prewire connector (1).
34. Plug pre-wire connector into the mating connector on the trailer patch (2) (102056-WL).
35. Route the blue connector (3) along rear of the vehicle.

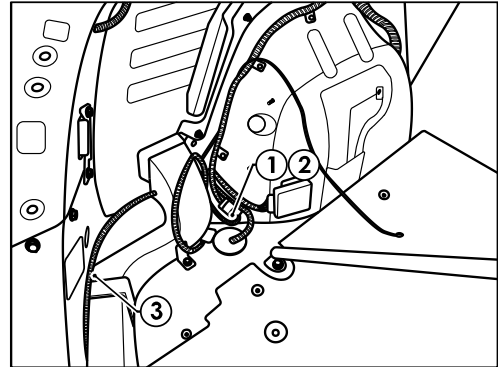

36. Route the earth ring terminal (1) over the LHS wheel arch.
 37. Route the ECU 12-way connector (2) up the 'D' pillar.
 38. Using alcohol wipe, clean the LHS inner sheet metal area (3) and the underside of the ECU (04826) (4).
 39. Connect the trailer patch 12-way connector (2) to the ECU (4).
 40. Apply double sided tape (5) to the ECU (4) and secure it to the vehicle sheet metal (3).
- Note: Mount the ECU, ensuring connector is orientated downwards.**

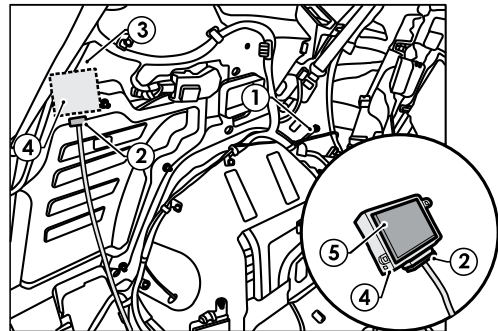

41. Route the ring terminal (1) towards the 'C' pillar.
 42. Connect the ground wire ring terminal (1) to the vehicle earthing point (2).
- Note: Use supplied Cable Ties to secure the harness away from the seat belt.**

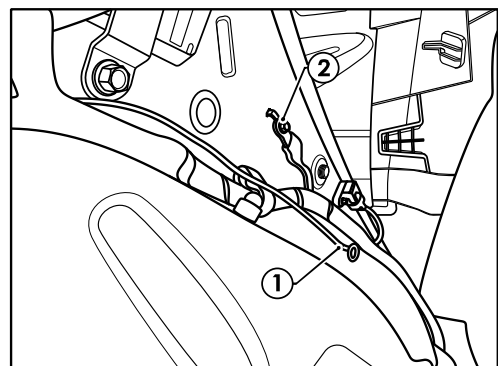



TOWBAR INSTALLATION INSTRUCTIONS

PART NUMBER 03372RW
HYUNDAI SANTA FE TM3 CL4

43. On the boot floor locate the factory 15mm grommet hole (1).
44. Drill out to 30mm using a step drill.
45. With the rear bumper removed, secure tail harness to towbar.
46. Route tail harness (1200mm) up through chassis rail and previously drilled grommet hole.
47. Seat grommet in 30mm hole and route to trailer harness blue connector on wiring loom.

Note: Keep harness routing clear of all sharp edges, moving parts and places of extreme heat.

Note: Ensure grommet is seated correctly and makes a good seal.

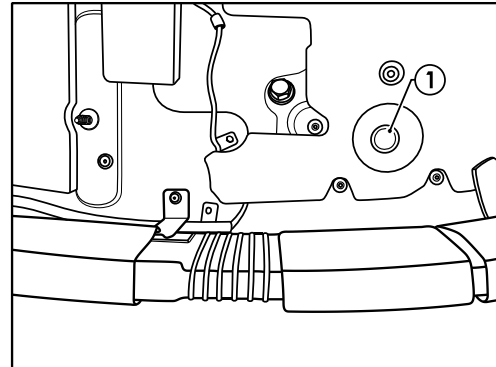

48. Connect the tail harness (tail length 1200mm) 8-way connector (1) to the trailer patch mating 8-way connector (2).
49. Secure all harness using supplied Cable Ties.
50. Test the trailer patch function using a light board or multimeter.
51. Re-fit all removed parts and secure all fasteners, ensuring there are no squeaks or rattles.
52. The RPA function can be disabled via a switch next to the transmission lever.
53. Place the fitting instructions in the glove box after fitment.

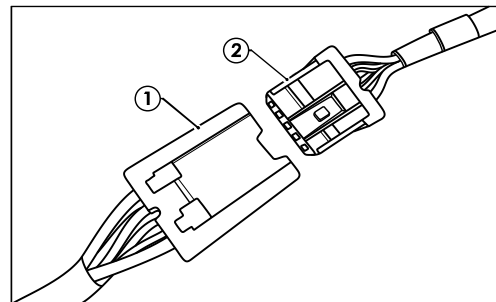



TOWBAR INSTALLATION INSTRUCTIONS

PART NUMBER 03372RW

HYUNDAI SANTA FE TM3 CL4

Bumper Cut Out Template

1. Measure the template to ensure all dimensions are to scale before cutting.
2. Mark the centre line on the painted surface of bumper.
3. Place the template on the outside of the bumper.
4. Align the centre line of the bumper and the template.
5. Align the lowest edge of the bumper and the template.

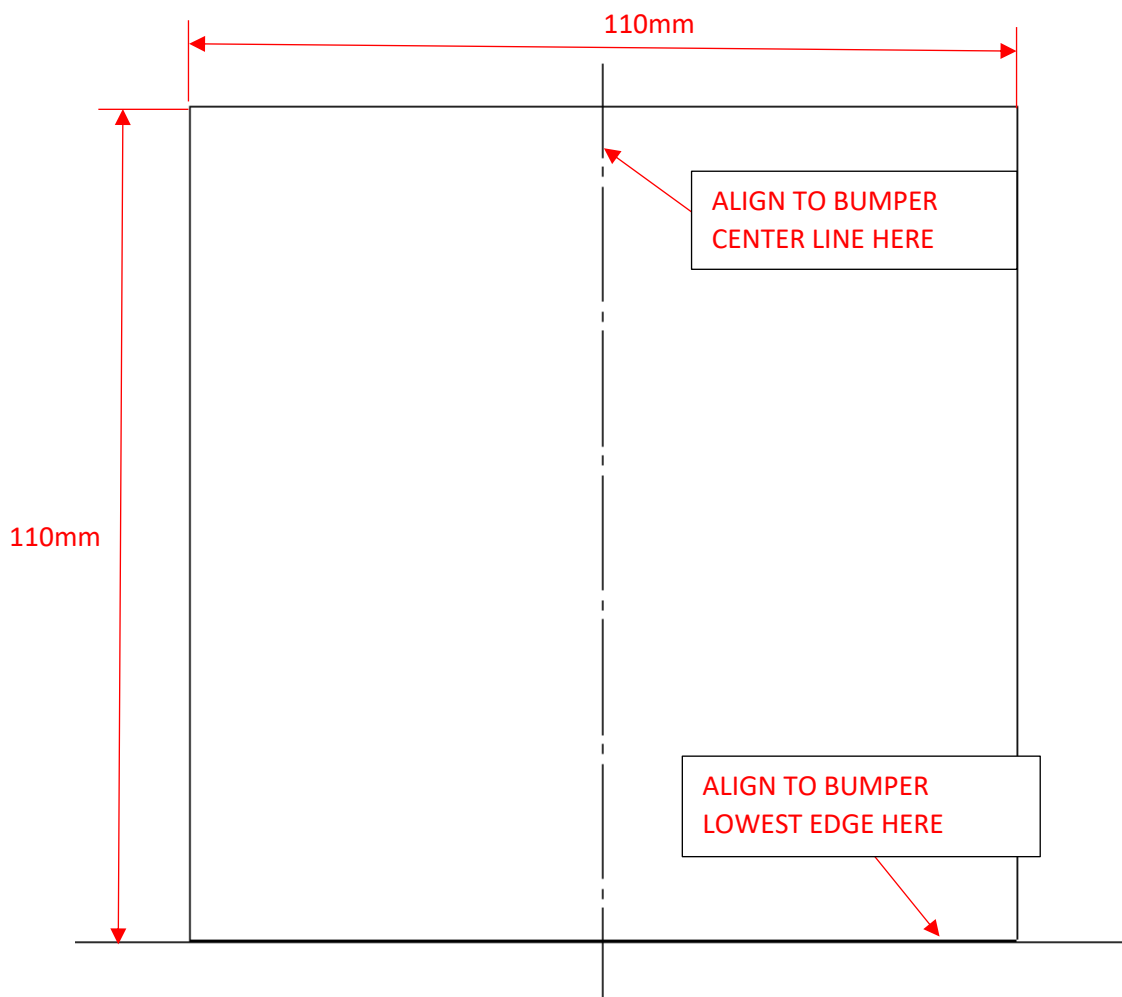



CUSTOMER INFORMATION

PLACE THESE INSTRUCTIONS IN THE VEHICLE'S GLOVEBOX AFTER INSTALLATION

**THANK YOU FOR PURCHASING HAYMAN REESE.
WITH CORRECT MAINTENANCE AND CARE THIS PRODUCT WILL PROVIDE A
LIFETIME OF TROUBLE-FREE OPERATION.**

TOWBAR MAINTENANCE AND CARE:

1. Hayman Reese recommend that the towbar LUG or TBM (tow ball Mount) Pull Pin and R-clip are removed and stored when not in use. Removal of LUG or TBM (tow ball mount) is advisable when not in use to assist with any of the following.
 - Ensure rear number plate is not obscured.
 - Allow maximum available departure angle and prevent any potential interference.
 - Prevent possible interference with vehicles reverse sensors or camera detecting a tow ball mount as an obstruction during reversing.
 - Removes towball mount as an obstruction for when moving around the rear of the vehicle.
2. Hayman Reese recommends routine inspection of your towbar to ensure trouble free towing.
 - Bolt security and tension should be regularly inspected and checked for correct tension. Replace any worn or defective parts with suitable grade & class fasteners. Inspection should be requested to coincide with vehicle major services.
3. It is the owner's responsibility to ensure towing and down ball weight capacities of the towing vehicle are not exceeded.
 - Towing and down ball weights allowable may differ according to model variations. Please refer to owner's manual or vehicle dealer to confirm exact rating for your vehicle model variant.
 - It is not uncommon for the vehicle tow rating to differ from the towbar rating. When this occurs, the lesser rating must be adhered to.
 - For vehicles fitted with enhanced vehicle functions that may be altered/changed when towing i.e Trailer sway mitigation, blind spot detection, adaptive cruise control etc. Please consult owner's manual to understand changes enabled when towing and after towing.



WARRANTY INFORMATION:

Hayman Reese Towbars are covered by a Lifetime Warranty.

Our goods come with guarantees that cannot be excluded under the Australian Consumer Law. You are entitled to a replacement or refund for a major failure and for compensation for any other reasonably foreseeable loss or damage. You are also entitled to have the goods repaired or replaced if the goods fail to be of acceptable quality and the failure does not amount to a major failure.

For further details please visit www.haymanreese.com.au/warranty or contact customer service on 1800 812 017 or info@haymanreese.com.au.



CUSTOMER INFORMATION

PLACE THESE INSTRUCTIONS IN THE VEHICLE'S GLOVEBOX AFTER INSTALLATION

HAYMAN REESE SMART PIN

Your Hayman Reese towbar is equipped with Smart Pin technology to help reduce towbar tongue rattle in most driving conditions. Please ensure below instructions are understood and routine maintenance is carried out to ensure best towing experience.

i Regularly inspect for wear and check the tightness of the Smart Pin Nut. Follow instructions below to re-tighten the nut as necessary when movement and noise in the tow ball mount is noted.

- Before towing, ensure R-Clip is properly installed and Smart pin nut is installed and tensioned. Replacement parts are available from your Hayman Reese Distributor.

TOWBALL MOUNT REMOVAL/INSTALLATION

STEP 1

Insert Trailer Ball Mount (TBM) (a) into towbar hitchbox (b), aligning hole in TBM shank (c) with hole in hitchbox (d) (Fig. 1)

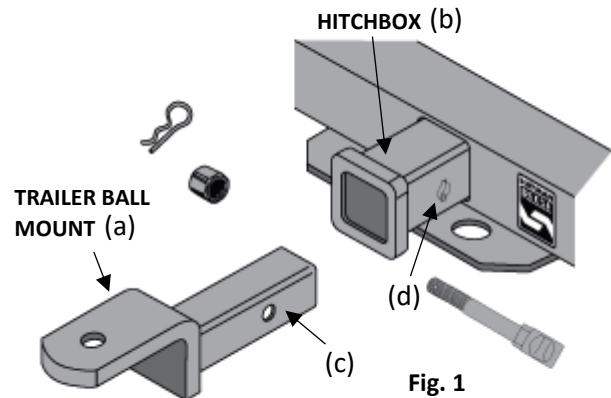

STEP 2

Insert Smart Pin (e) through hole in hitchbox and hole in TBM shank (g); ensure the locators are inserted into the notches in the hitchbox (Fig. 2)

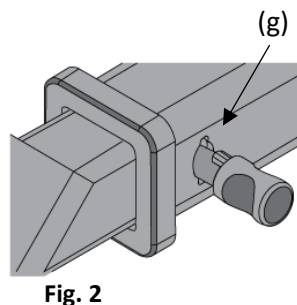

STEP 3

Screw Smart Pin Nut (f) onto Smart Pin (g); tighten Smart Pin Nut until finger tight, ensuring TBM is restrained from up and down movement.

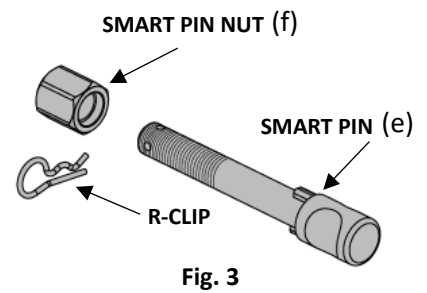

STEP 4

Tighten Smart Pin Nut by turning nut a further 1/8th of a turn in the clockwise direction using a 24mm spanner (Fig. 4).

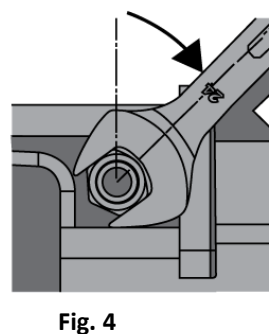

STEP 5

Install Smart Pin R-Clip through the hole that provides best clearance or easiest access. (Fig. 5)

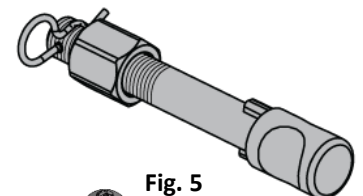

STEP 6

Install towball onto TBM and tighten to **350 Nm** using a calibrated torque wrench (Fig. 6).

