



TOWBAR INSTALLATION INSTRUCTIONS

PART NUMBER 03300XW

TOYOTA HILUX GUN TUB X-BAR



PRODUCT DETAILS:

Part Number:	03300XW	Maximum Towing Braked:	3500	kg
ECU Number:	04835	Maximum Towing Unbraked:	750	kg
Tail Harness Length Required:	1800mm	Maximum Static Ball Load:	350	kg
TBM/Lug Part Number:	21366			
Wiring Part Number:	101247-WL			

FITTING DETAILS:

Towbar Installation Time:	90 mins.	Vehicle Coding Required:	NO
Wiring Installation Time:	30 mins.	RPA Disable/Other:	NO
Total Installation Time:	2 hrs.	Note:	
Bumper Cut Required:	No		<ul style="list-style-type: none">• Small cut required on underside of bumper bar.



TOWBAR INSTALLATION INSTRUCTIONS

PART NUMBER 03300XW

TOYOTA HILUX GUN TUB X-BAR

ENSURE THAT INSTRUCTIONS ARE UNDERSTOOD PRIOR TO FITMENT.

i BEFORE YOU START:

Hayman Reese recommends that instructions are read completely prior to fitment. Check all hardware items have been included refer to assembly diagram. Please ensure this towbar is only fitted to vehicle models as per Hayman Reese application guide (www.haymanreese.com.au).

Bumper Cuts



Vehicle and bumper variations can and do occur during vehicle manufacture after initial towbar design. Fitment of towbar to vehicle and accuracy of bumper cut must be assessed prior to any bumper modifications made. Incorrect bumper cuts are not covered under Hayman Reese warranty.

NOTE: Bumper cuts need to be approached with care, refer to notes below.

- Bumper centreline – where the centreline of the bumper needs to be determined, the installer must assess centre point by measurement of bumper width or determining two symmetrical reference points to give centreline.
- Bumper edge – To assist with accurate bumper cut measurement, reference to the start of the bumper edge is now being commonly used.
 - Measure from bottom edge along bumper and around corner to the 70 mm point (Figure 1).
 - Do not measure from visible bumper front of corner, upwards (Figure 2).

CORRECT

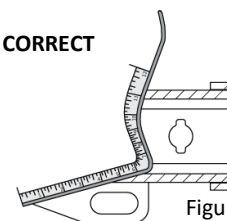

Figure 1

INCORRECT

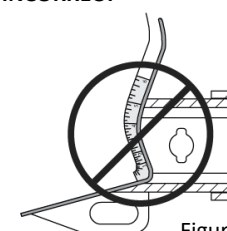

Figure 2

Drilling

- For any required drilling during installation, ensure that the area is clear of fuel, electrical & other components that may be damaged.
- All holes drilled into the body panels shall have all burrs & swarf removed then coated with a suitable rust preventative paint.

Bolts/Fasteners

- Ensure that all hardware is fastened to correct torque as specified in this fitting instruction.
- All fasteners supplied with this product are used to achieve a specified clamp loading. If replacement is required ensure that fasteners of the same grade and class are used.



NOTE: Achieving correct torque is critical to proper installation and responsibility of the installer. Towbar failures attributed to tension issues from over tightening or under tightening are not covered by Hayman Reese warranty.

Product Labels

- a. Towbar load rating sticker provided with this product shall be conspicuously located on inside rear end of the driver's door.
- b. Powertrain Control Module (PCM)/Body Control Module (BCM) upgrade warning label will be provided in towbar kit for vehicles as required. Affix warning label in door and owner's handbook.

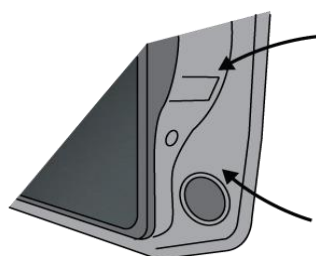

Place **Load Rating sticker** inside driver's door here

Place **Vehicle PCM/ BCM upgrade warning label** in door AND on front cover of owner's service handbook

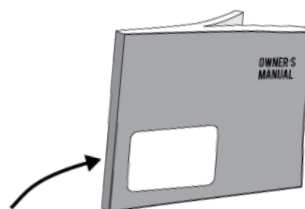

WARNING:

Do not, drill, cut, weld or otherwise modify the towbar.

FOR TOWING PURPOSES ONLY - This towbar is designed and tested by Hayman Reese to adhere to ADR 62/02 which provides only for the expected load demands of towing.



TOWBAR INSTALLATION INSTRUCTIONS

PART NUMBER 03300XW

TOYOTA HILUX GUN TUB X-BAR

i TOWBAR ASSEMBLY DIAGRAM

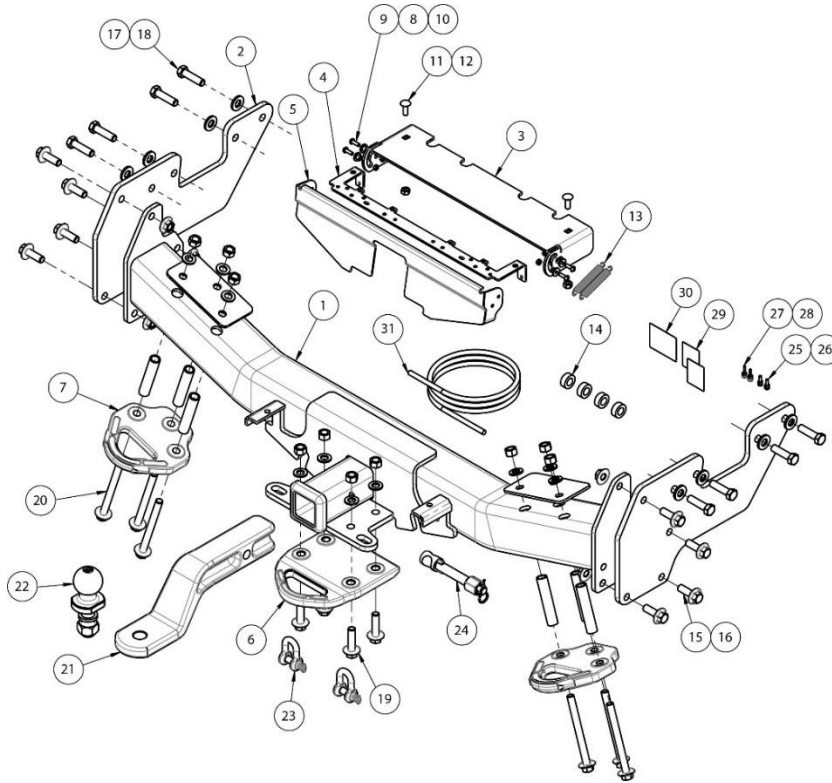

ITEM	DESCRIPTION	QTY
1	TOYOTA HILUX X-BAR WELDED ASSEMBLY	1
2	SIDE ARM	2
3	WIRING HOUSING	1
4	PLUG PLATE	1
5	X-BAR REAR COVER	1
6	FORGED CENTRE RECOVERY HOOK	1
7	FORGED SIDE RECOVERY HOOK	2
8	BUSH 15ODx8Lx5ID	4
9	SCREW PAN HD M5x16x0.8P	4
10	NUT NYLON INS LOCK HEX M5x0.8P	4
11	BOLT COACH M8x20x1.25P	2
12	NYLOC NUT M8x1.25P	2
13	XBAR COVER SPRING 60L x 100D x 1P	2
14	10MM ROUND SPACER 25MM DIA	4
15	FLANGED SET SCREW M12x35x1.25P	8
16	FLANGED NUT HEX M12x1.25P	8

ITEM	DESCRIPTION	QTY
17	WASHER PLAIN 1/2X1-1/8X16G	8
18	SET SCREW HEX HD M12x45x1.25P	8
19	CENTRE RECOVERY HOOK BOLT KIT	1
20	SIDE RECOVERY HOOK BOLT KIT	2
21	3.5T FORGED TBM 65MM DROP	1
22	HR TOWBALL	1
23	10mm "D" SHACKLE	2
24	ANTI-RATTLE PULL PIN ASSY GOLD	1
25	SCREW PAN HD M4x16x0.7P	2
26	NUT NYLON LOCK HEX HD M4x0.7P	2
27	SCREW PAN HD M3x20x0.7P	2
28	NUT NYLON LOCK HEX HD M3x0.7P	2
29	X-BAR LOGO STICKER	2
30	ACRYLIC COMPLIANCE LABEL	1
31	WIRING LOOM	1



TOWBAR INSTALLATION INSTRUCTIONS

PART NUMBER 03300XW

TOYOTA HILUX GUN TUB X-BAR

NOTE: Pre-assembly of X-Bar centre section can assist for vehicles with difficult access.

A. BOLT RECOVERY HOOKS TO TOWBAR

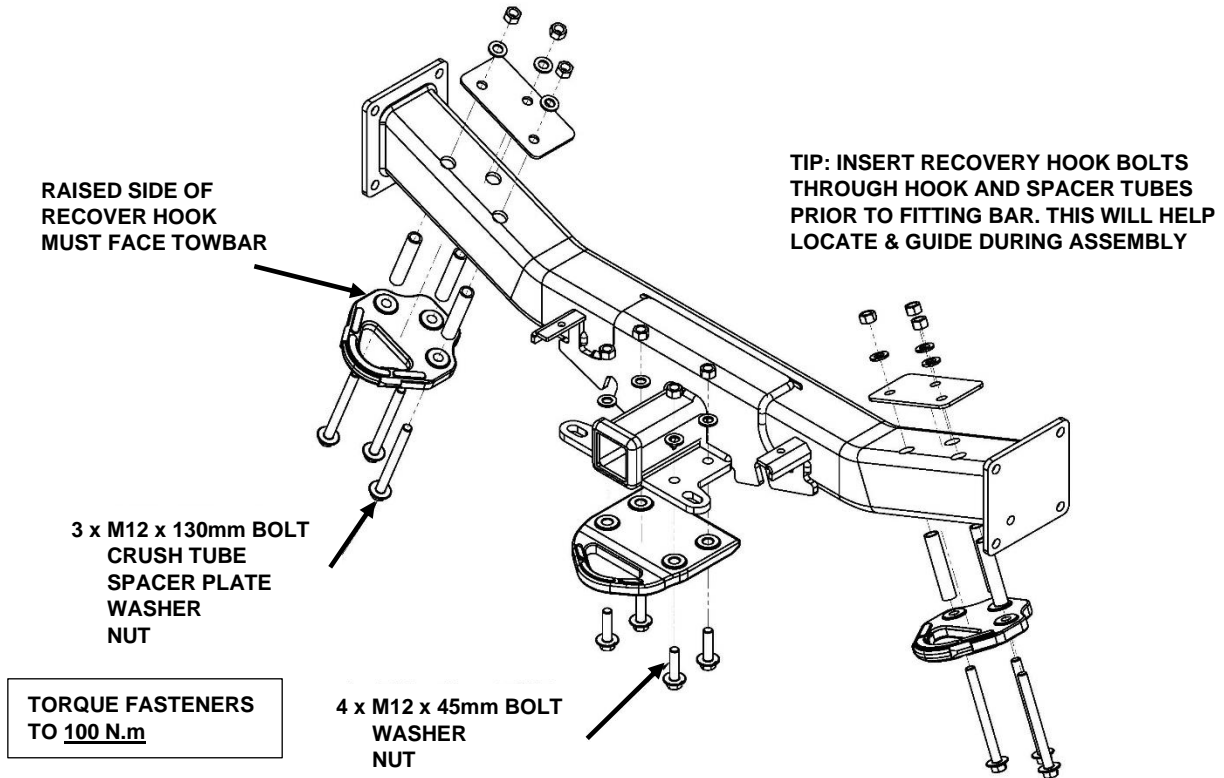

B. MOUNT PLUGS TO BRACKET

AFTER CHOOSING YOUR DESIRED PLUG CONFIGURATION, INSTALL PLUGS AND WIRING TO BRACKET USING FASTENERS PROVIDED

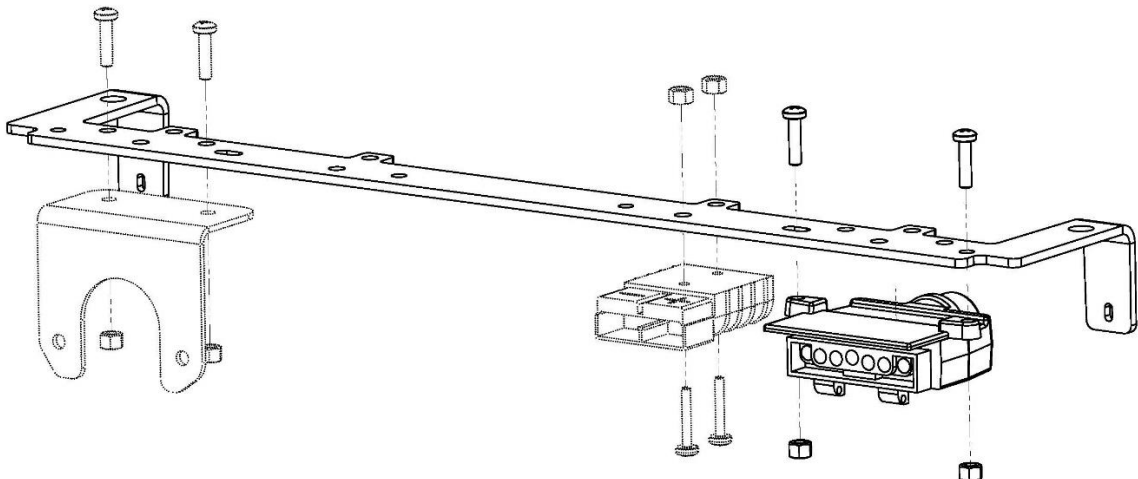



TOWBAR INSTALLATION INSTRUCTIONS

PART NUMBER 03300XW

TOYOTA HILUX GUN TUB X-BAR

C. INSTALL WIRING HOUSING

USING 2 x M8 COACH BOLTS COMPLETE WITH 1 x NYLOC NUT PER BOLT, SECURE THE WIRING HOUSING AND PLUG BRACKET TO THE MAIN TOWBAR ASSEMBLY THROUGH THE TAB HOLES AS SHOWN.

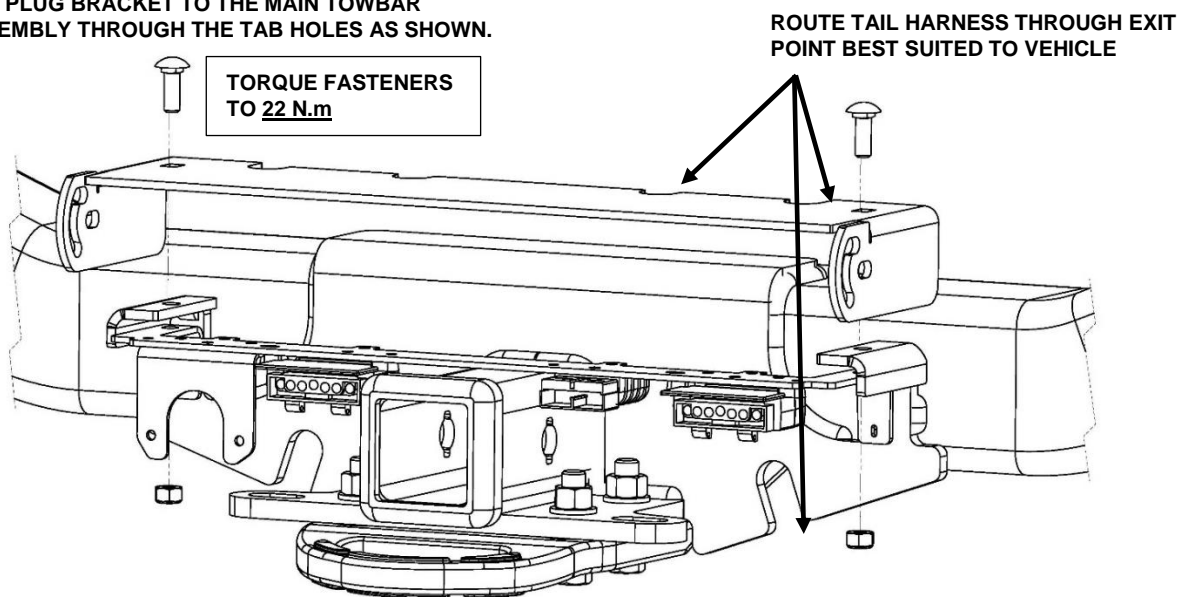

D. ATTACH COVER TO HOUSING

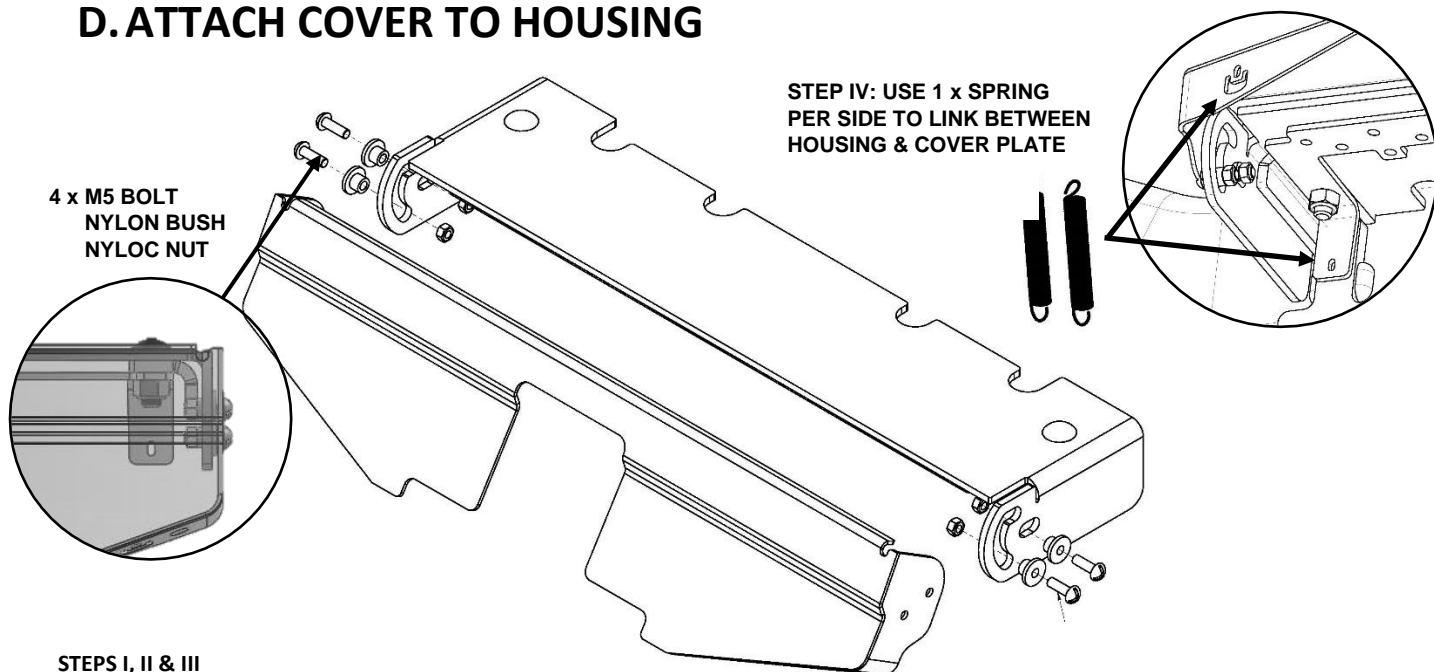

STEPS I, II & III

- I. INSERT BUSHES INTO SLOTS
- II. THEN PLACE COVER OVER HOUSING, LINING UP BUSHES WITH SCREW HOLES
- III. FINALLY FASTEN COVER TO HOUSING BY PUSHING SCREWS THROUGH BUSHES AND SECURING WITH NUTS

NOTE: DO NOT OVERTIGHTEN FASTENERS TO ENSURE COVER ASSEMBLY CAN ROTATE FREELY & TO PREVENT DAMAGE TO BUSHES



TOWBAR INSTALLATION INSTRUCTIONS

PART NUMBER 03300XW

TOYOTA HILUX GUN TUB X-BAR

INSTALLATION TO VEHICLE

1. Detach rear step on vehicle by removing 2 x M12 set screws located on the most rearward position of chassis rail. Repeat for opposite side.

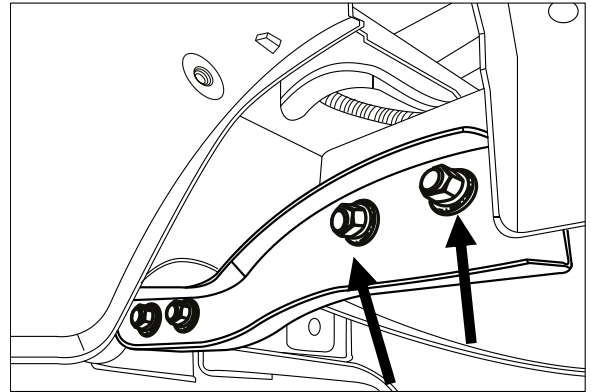

2. Loosely secure sidearm by using 2 x M12 x 1.25P set screws with flat washers on the most forward two mounting points on the vehicle. Repeat for opposite side.

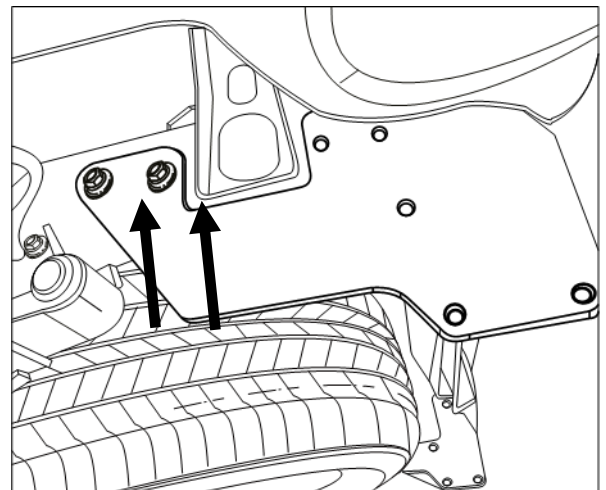

3. With 2 people, lift centre section up to vehicle and loosely secure to sidearms by inserting 2 x M12 x 1.25P flanged bolts, complete with 1 x flanged nut per bolt, on the **bottom** matching mounts on the towbar.

Repeat for opposite side.

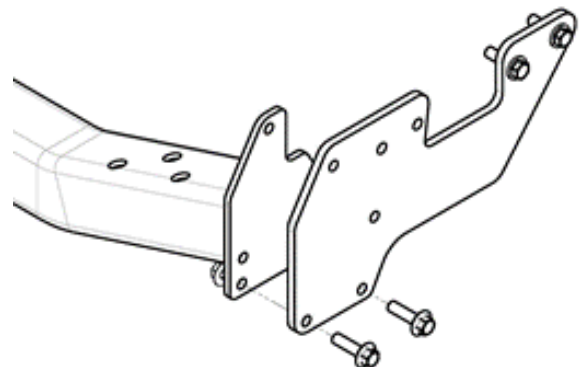



TOWBAR INSTALLATION INSTRUCTIONS

PART NUMBER 03300XW

TOYOTA HILUX GUN TUB X-BAR

4. On the factory step, remove the 2 x mounting brackets, secured to the step with 2 x M12 bolts per side.

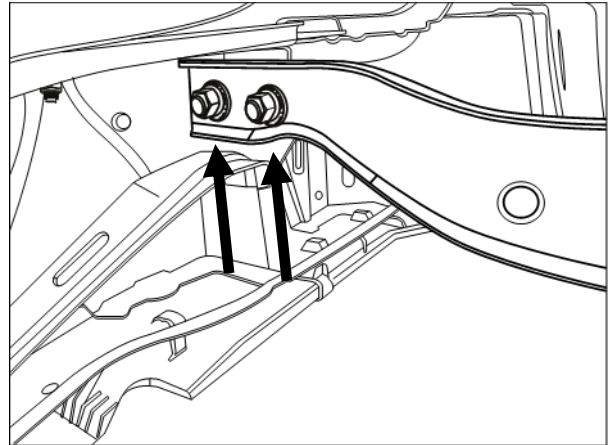

5. Re-attach the mounting brackets to the step, putting the 10mm spacers (1) supplied between the bracket and step (1 per bolt).

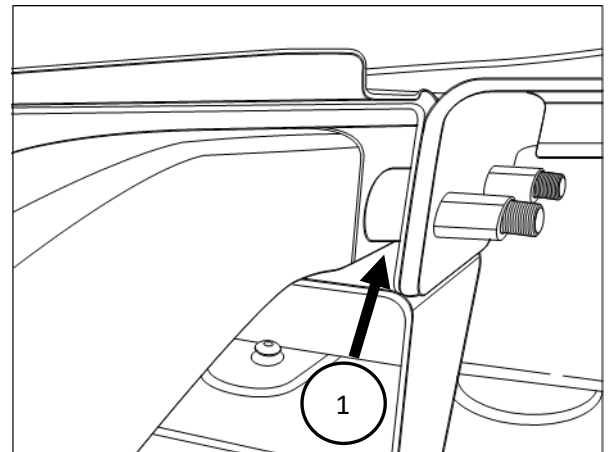

6. On the underside of the step, trim 15mm across and 10mm in line with the sidearm to relieve any contact with the towbar side arm and step.

Repeat for the opposite side of the vehicle.

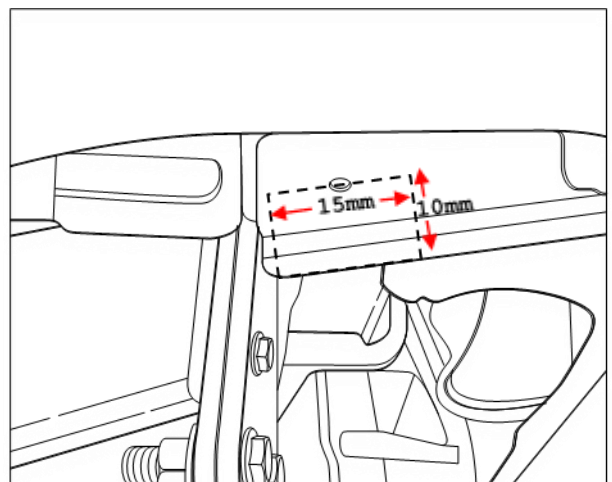



TOWBAR INSTALLATION INSTRUCTIONS

PART NUMBER 03300XW

TOYOTA HILUX GUN TUB X-BAR

- Loosely insert 1 x M12 x 1.25P set screw with flat washer to the second last rear mounting point on the vehicle (1). Repeat for opposite side.
- Re-attach the factory step, sliding over the 2 loosely secured bolts. Secure step with remaining 1 x M12 set screw with accompanying washer, each side (2).
- Secure centre section to sidearm with remaining 2 x M12 flanged bolts, complete with 1 x flanged nut per bolt.

Repeat for opposite side.

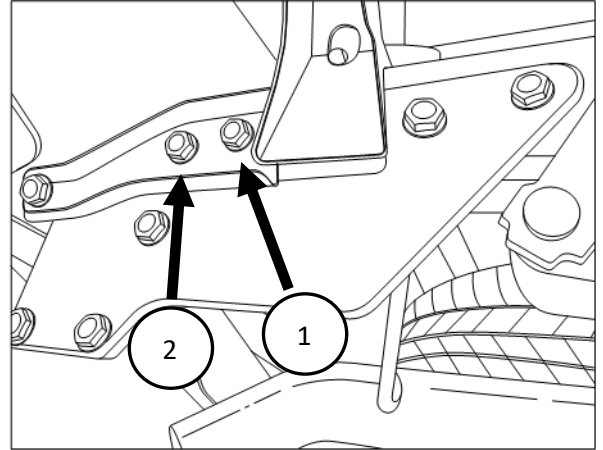

10. If not already done, complete pre-assembly steps A, B, C & D now.

11. Torque all bolts as follows:

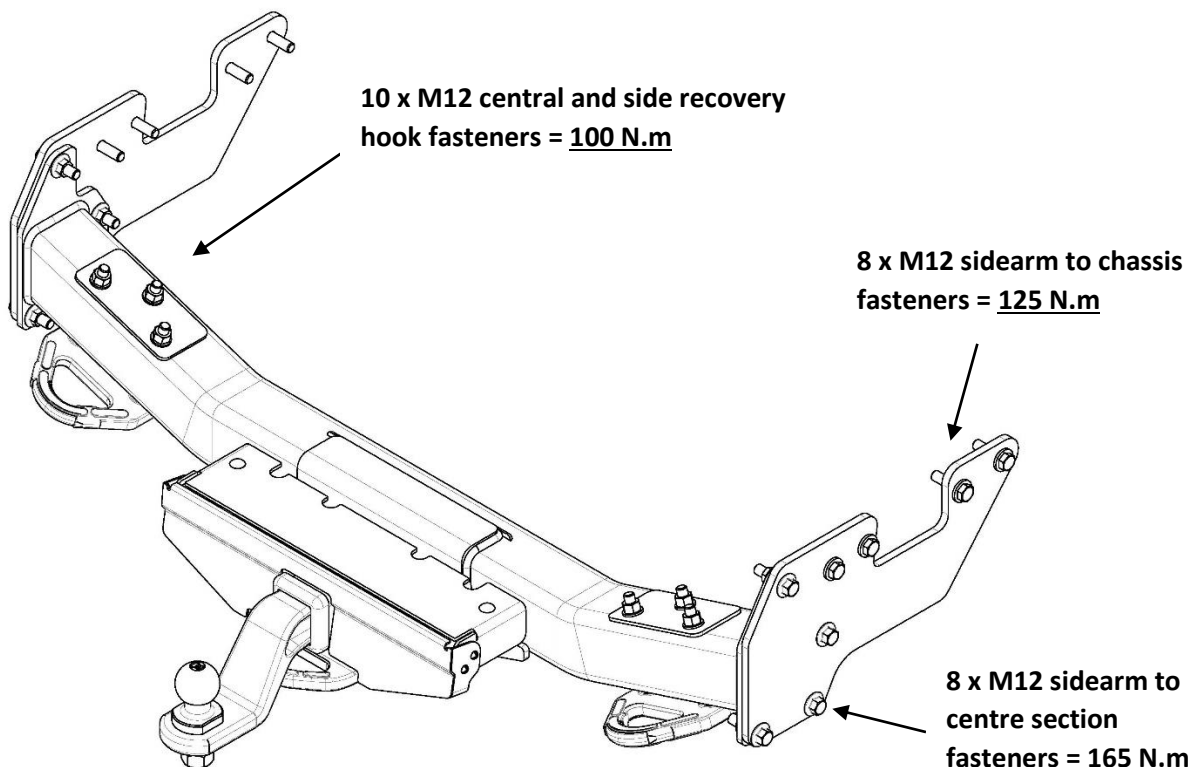

IMPORTANT: Ensure all bolts are tightened to correct torques using a calibrated torque wrench. Tighten side arms to chassis rail first in an even pattern/sequence. Repeat for centre section to side arms and finally torque all other fasteners.



TOWBAR INSTALLATION INSTRUCTIONS

PART NUMBER 03300XW

TOYOTA HILUX GUN TUB X-BAR

IMPORTANT

Due to possible vehicle variations, always confirm any noted vehicle colour wires with a multi-meter to ensure the correct function is identified before soldering or scotch locking. For vehicle wires denoted with two colours (example; RED/GREEN) the first colour will always be the main wire colour while the second colour is the thinner trace colour on the wire.

12. Disconnect and remove the LHS and RHS tail light assemblies (1) by removing the two fasteners from each tail light.

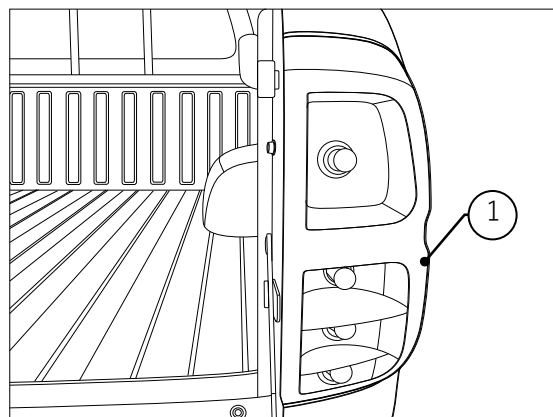

13. From underneath the vehicle, route the trailer patch harness (P/No: 101247-WL) connectors (1) up the RHS tail light cavity.

Patch the trailer patch harness RHS connectors (1) to the the tail light connector (2) and refit the RHS tail light assembly.

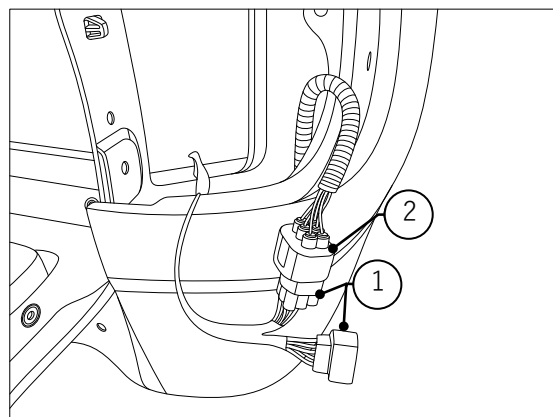



TOWBAR INSTALLATION INSTRUCTIONS

PART NUMBER 03300XW

TOYOTA HILUX GUN TUB X-BAR

14. Underneath the vehicle, route the trailer patch harness (1) over the support bar and along the vehicle harness towards the LHS tail light cavity.

Patch the trailer patch harness LHS connectors (1) to the tail light connector (2).

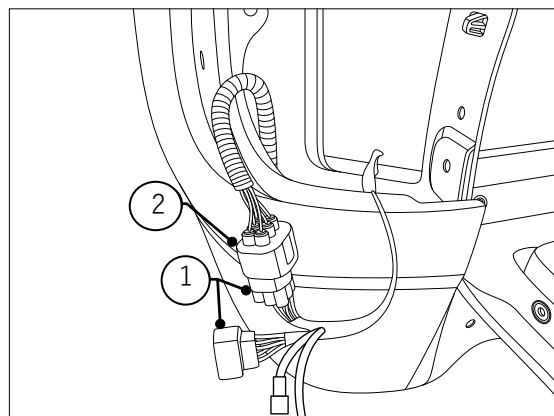

15. Connect the trailer patch connector (1) to the ECU (P/No: 04835) (2).
16. In the tail light cavity, clean the inner skin of the lower bumper sheet metal area with an alcohol wipe (not supplied) for ECU mounting location.
17. Remove the backing from the back of the ECU and mount the ECU (2) to the cleaned area (3).
Ensure the ECU connector is pointing downwards.

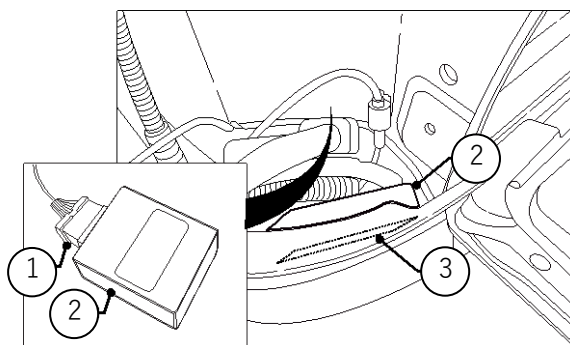

18. Connect the trailer patch ORANGE wire 1-way connector (1) to the Power Harness (P/No: 04825) mating 1-way connector (2).
Refit the tail light assembly.

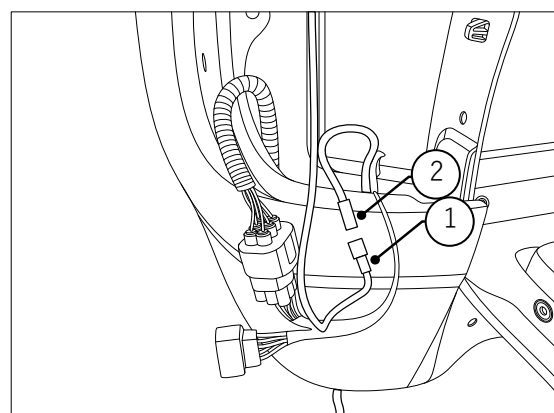



TOWBAR INSTALLATION INSTRUCTIONS

PART NUMBER 03300XW

TOYOTA HILUX GUN TUB X-BAR

19. Route the power harness (1) along the LHS chassis rail to the engine bay. **Ensure to secure harness away from any moving parts or sharp objects and sources of extreme heat with cable ties (not supplied).**

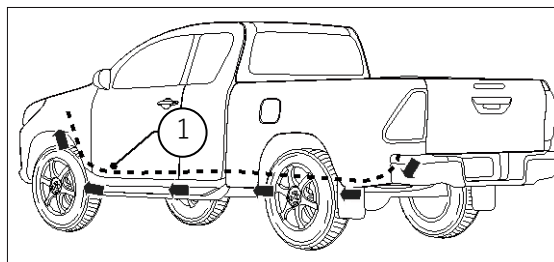

20. Route the power harness up to the battery.
21. Secure the power harness ring terminal (1) onto the battery positive terminal fastener (2).

Note: Be careful when removing the positive nut not to short your tool on the vehicle.

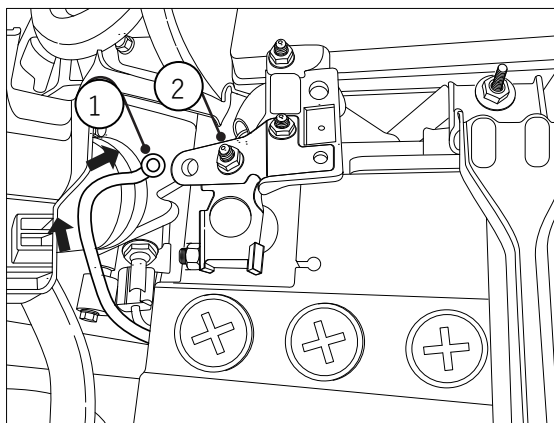

22. Route the tail harness (tail length: 1800mm) from the towbar (1) along the rear LHS of the vehicle (2).

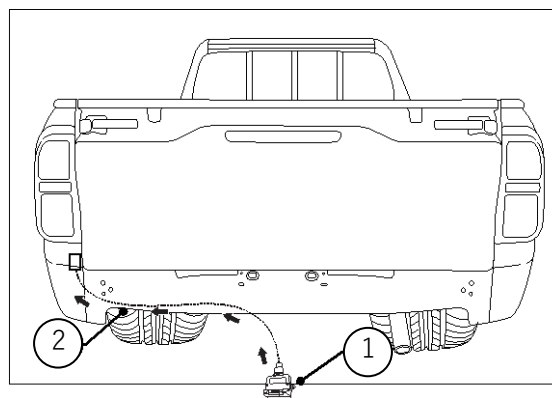



TOWBAR INSTALLATION INSTRUCTIONS

PART NUMBER 03300XW

TOYOTA HILUX GUN TUB X-BAR

-
23. Connect the tail harness 8-way connector (1) to the trailer patch 8-way mating connector (2).
 24. **Waterproof the trailer patch 8-way connector (1) and the tail harness 8-way male connector (2) using silicone or grease (3) (not supplied).**

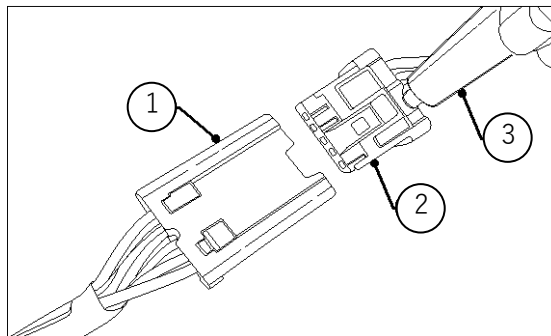

-
25. Test the trailer harness function using a light board or multi-meter.
 26. Secure all harnesses using cable ties (not supplied).
 27. Re-fit all removed parts and secure all fasteners, ensure there are no squeaks or rattles.
 28. Place instructions in glove box after fitment.
-



CUSTOMER INFORMATION

PLACE THESE INSTRUCTIONS IN THE
VEHICLE'S GLOVEBOX AFTER INSTALLATION

**THANK YOU FOR PURCHASING HAYMAN REESE.
WITH CORRECT MAINTENANCE AND CARE THIS PRODUCT WILL PROVIDE A
LIFETIME OF TROUBLE-FREE OPERATION.**

i TOWBAR MAINTENANCE AND CARE:

1. Hayman Reese recommend that the towbar LUG or TBM (tow ball Mount) Pull Pin and R-clip are removed and stored when not in use. Removal of LUG or TBM (tow ball mount) is advisable when not in use to assist with any of the following.
 - Ensure rear number plate is not obscured.
 - Allow maximum available departure angle and prevent any potential interference.
 - Prevent possible interference with vehicles reverse sensors or camera detecting a tow ball mount as an obstruction during reversing.
 - Removes towball mount as an obstruction for when moving around the rear of the vehicle.
2. Hayman Reese recommends routine inspection of your towbar to ensure trouble free towing.
 - Bolt security and tension should be regularly inspected and checked for correct tension. Replace any worn or defective parts with suitable grade & class fasteners. Inspection should be requested to coincide with vehicle major services.
3. It is the owner's responsibility to ensure towing and down ball weight capacities of the towing vehicle are not exceeded.
 - Towing and down ball weights allowable may differ according to model variations. Please refer to owner's manual or vehicle dealer to confirm exact rating for your vehicle model variant.
 - It is not uncommon for the vehicle tow rating to differ from the towbar rating. When this occurs, the lesser rating must be adhered to.
 - For vehicles fitted with enhanced vehicle functions that may be altered/changed when towing i.e Trailer sway mitigation, blind spot detection, adaptive cruise control etc. Please consult owner's manual to understand changes enabled when towing and after towing.

i WARRANTY INFORMATION:

Hayman Reese Towbars are covered by a Lifetime Warranty.

Our goods come with guarantees that cannot be excluded under the Australian Consumer Law. You are entitled to a replacement or refund for a major failure and for compensation for any other reasonably foreseeable loss or damage. You are also entitled to have the goods repaired or replaced if the goods fail to be of acceptable quality and the failure does not amount to a major failure.

For further details please visit www.haymanreese.com.au/warranty or contact customer service on 1800 812 017 or info@haymanreese.com.au.



CUSTOMER INFORMATION

PLACE THESE INSTRUCTIONS IN THE VEHICLE'S GLOVEBOX AFTER INSTALLATION

HAYMAN REESE SMART PIN

Your Hayman Reese towbar is equipped with Smart Pin technology to help reduce towbar tongue rattle in most driving conditions. Please ensure below instructions are understood and routine maintenance is carried out to ensure best towing experience.

i Regularly inspect for wear and check the tightness of the Smart Pin Nut. Follow instructions below to re-tighten the nut as necessary when movement and noise in the tow ball mount is noted.

- Before towing, ensure R-Clip is properly installed and Smart pin nut is installed and tensioned. Replacement parts are available from your Hayman Reese Distributor.

TOWBALL MOUNT REMOVAL/INSTALLATION

STEP 1

Insert Trailer Ball Mount (TBM) (a) into towbar hitchbox (b), aligning hole in TBM shank (c) with hole in hitchbox (d) (Fig. 1)

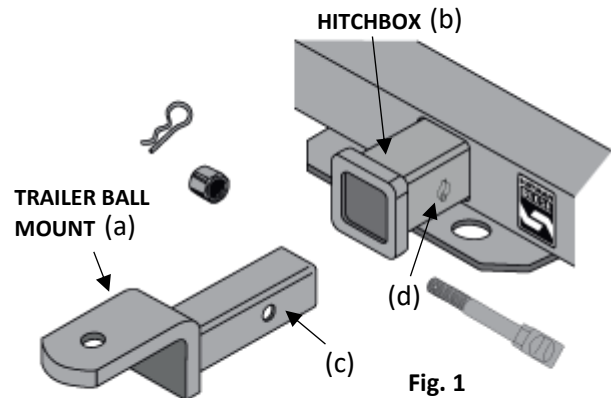

STEP 2

Insert Smart Pin (e) through hole in hitchbox and hole in TBM shank (g); ensure the locators are inserted into the notches in the hitchbox (Fig. 2)

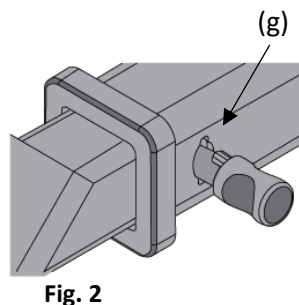

STEP 3

Screw Smart Pin Nut (f) onto Smart Pin (g); tighten Smart Pin Nut until finger tight, ensuring TBM is restrained from up and down movement.

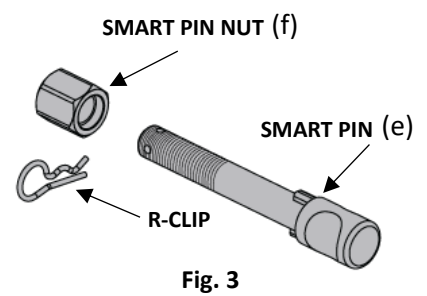

STEP 4

Tighten Smart Pin Nut by turning nut a further 1/8th of a turn in the clockwise direction using a 24mm spanner (Fig. 4).

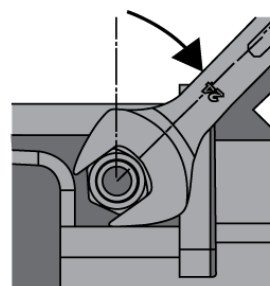

STEP 5

Install Smart Pin R-Clip through the hole that provides best clearance or easiest access. (Fig. 5)

