

HAYMAN REESE
PART No: **03267RW**
MITSUBISHI TRITON MR MY19 CL4 UTE
INSTALLATION INSTRUCTIONS

PLEASE ENSURE THAT ALL INSTRUCTIONS ARE UNDERSTOOD PRIOR TO FITMENT
PLACE THESE INSTRUCTIONS IN THE VEHICLE'S GLOVEBOX AFTER INSTALLATION IS COMPLETED



Installation Time: Approx 30 Mins

Towbar Installation Instructions

Towbar capacity

MITSUBISHI TRITON MR MY19 CL4 UTE

Part Number 03267RW	Max Towing Braked	3100 kg
	Max Towing Unbraked	750 kg
	Max Static Ball Load	310 kg

Hayman Reese (Cequent)
PO Box 4050, Dandenong South VIC 3164
Phone 1800 812 017 Email info@haymanreese.com.au

HAYMAN REESE

PART No: 03267RW

MITSUBISHI TRITON MR MY19 UTE

INSTALLATION INSTRUCTIONS

PLEASE ENSURE THAT ALL INSTRUCTIONS ARE UNDERSTOOD PRIOR TO FITMENT
PLACE THESE INSTRUCTIONS IN THE VEHICLES'S GLOVEBOX AFTER INSTALLATION IS COMPLETED

Warning:

1. Do not, drill, cut, weld or otherwise modify the towbar.
2. If you are using electric welding on a motor vehicle, **always** check that the vehicle is not equipped with electronic engine or instrument management equipment. Failure to do so could **destroy** any onboard computers. In if doubt, check with the vehicle's manufacturer.
3. If TBM is used in inverted position tow ball may make contact with rear tailgate when lowered, which could cause damage.

General:

1. Ensure all hardware items have been included refer to assembly diagram.
2. It is recommended that the instructions are read through and completely understood before making any attempt to fit this product.
3. Be wary of any changes to vehicle designs or other accessories that may conflict with the installation of this product.
4. Before drilling ensure that the area is clear of fuel, electrical & other components.
5. All holes drilled into the body panels shall have all burrs & swarf removed then coated with a suitable rust preventative paint.
6. The high tensile fasteners supplied with this product were used to achieve the specified rating. If replacement is required ensure that fasteners of the same rating & quality are used. Contact an authorised **Hayman Reese** dealer if further information is required.
7. Ensure that all hardware is fastened to torque list below check fasteners on regular basis.
8. Towbar load rating sticker provided with this product shall be conspicuously located on inside rear end of the driver's door. **(See diagram below)**.
9. Hayman Reese recommends that you check your tow ball to ensure that it complies with the Australian standards **AS 4177.2**.
10. **PLEASE NOTE:** It is advised to remove your LUG or TBM when not actually towing so as to produce a clear view of the vehicles registration plate if obscured, and to also provide maximum available departure angle.
11. Pull Pin must be fit in down position.

Tow bar Maintenance and Care.

Hayman Reese recommends that bolt torque's, as listed below, are routinely and regularly inspected and checked for correct tension. Replace any worn or defective parts.

We recommended to remove Tow Ball Mounts (TBM's, tongues or lugs) when not being used for any considerable length of time.

So as to avoid injury, when not towing it is suggested that the tongue, Pull Pin and R-clip are removed then stored in a safe, clean and dry place, away from excessive moisture.

Hitch Pull Pins and spring "R" clips are regularly checked for proper installation. Replace any worn or defective parts.

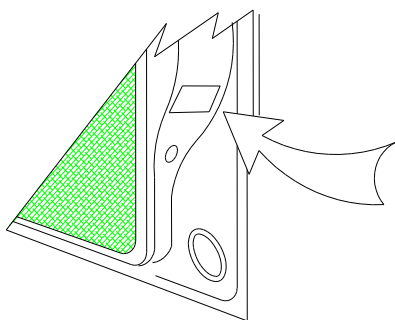

Place load rating sticker
inside driver's door here

RECOMMENDED ASSEMBLY TORQUE LISTING

Diameter Grade 8.8 Bolt

M6	9.5 Nm
M8	21.7 Nm
M10	43.4 Nm
M12	77.3 Nm
M14	146 Nm
M16	189.8 Nm

FOR TOWING PURPOSES ONLY

For towing capacity details please refer to vehicle owner's manual or to the manufacturer. Overloading can void your warranties.

HAYMAN REESE

PART No: 03267RW

MITSUBISHI TRITON MR MY19 UTE

INSTALLATION INSTRUCTIONS

PLEASE ENSURE THAT ALL INSTRUCTIONS ARE UNDERSTOOD PRIOR TO FITMENT
PLACE THESE INSTRUCTIONS IN THE VEHICLES'S GLOVEBOX AFTER INSTALLATION IS COMPLETED

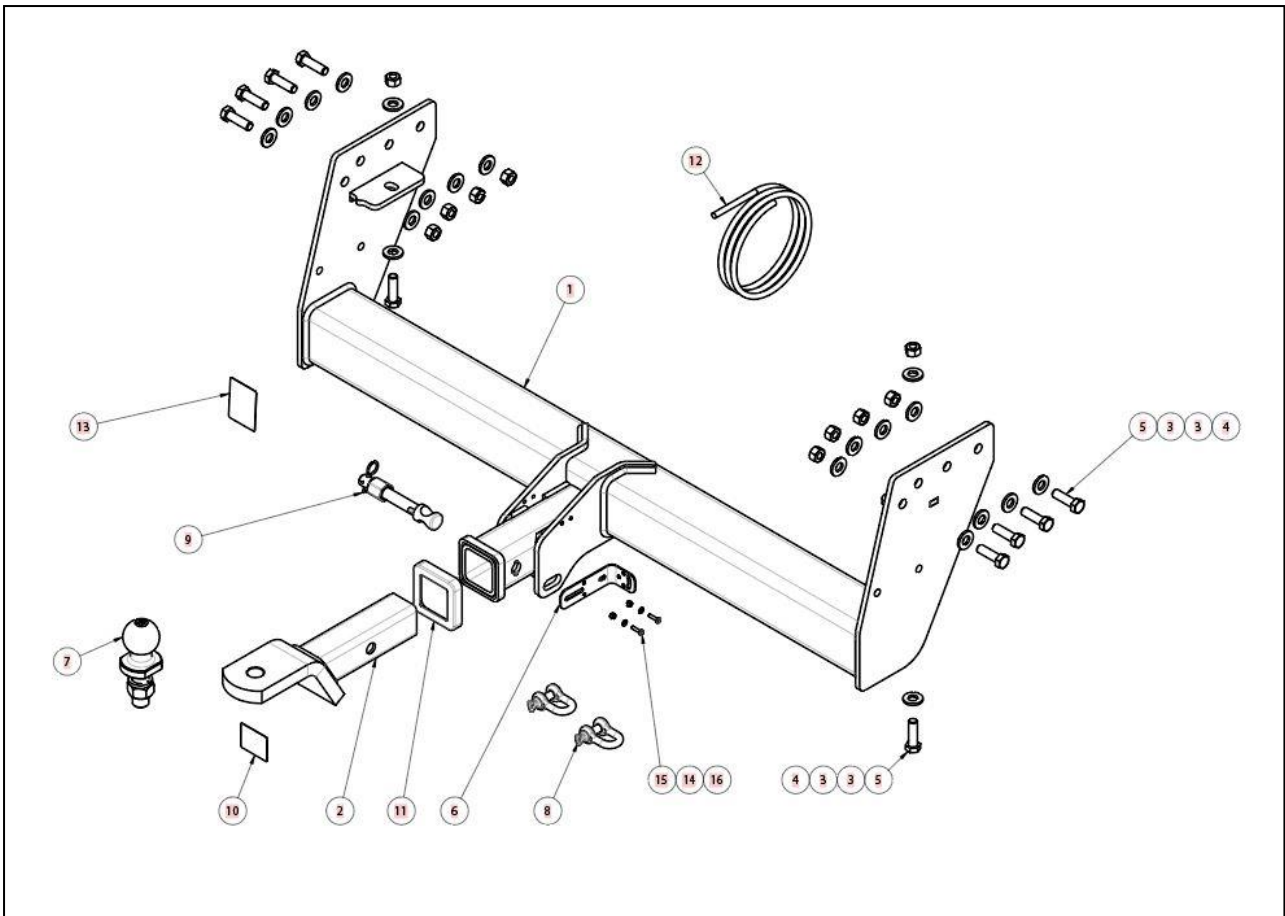

ITEM	DESCRIPTION	QTY
1	TRITON WITH STEP WELDED ASSY	1
2	CLASS 4 TBM	1
3	WASHER PLAIN 1/2X1-1/8X16G	20
4	M12x1.75 HEX NUT PC8	10
5	SET SCREW M12-1.75x40 GR10.9	10
6	UNIVERSAL PLUG BRACKET KIT	1
7	TOWBALL 50MM FLAT CHROME 3500KG HR	1
8	"D" SHACKLE 10mm	2
9	SMART PIN ASSY CLASS 4 – GOLD	1
10	HAYMAN REESE LOGO STICKER	1
11	HITCH BOX COLLAR COVER	1
12	WIRING LOOM	1
13	ACRYLIC COMPLIANCE LABEL	1
14	M4 WASHER	2
15	SCREW PAN HD M4 X 16 X 0.7P G4.6	2
16	NUT NYLON LOCK HEX HD M4X0.7P G8	2

HAYMAN REESE

PART No: 03267RW

MITSUBISHI TRITON MR MY19 UTE

INSTALLATION INSTRUCTIONS

PLEASE ENSURE THAT ALL INSTRUCTIONS ARE UNDERSTOOD PRIOR TO FITMENT
PLACE THESE INSTRUCTIONS IN THE VEHICLES'S GLOVEBOX AFTER INSTALLATION IS COMPLETED

1. Remove step from vehicle secured with 2 bolts per side, making sure to disconnect reversing sensors if fitted.

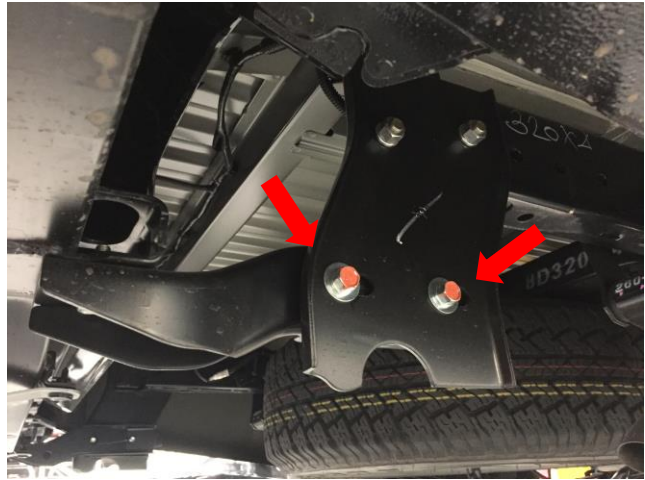

2. Remove LH Step bracket from vehicle secured with 2 x bolts complete with 2 x washers and 1 x nut per bolt and discard.

Repeat for other side.

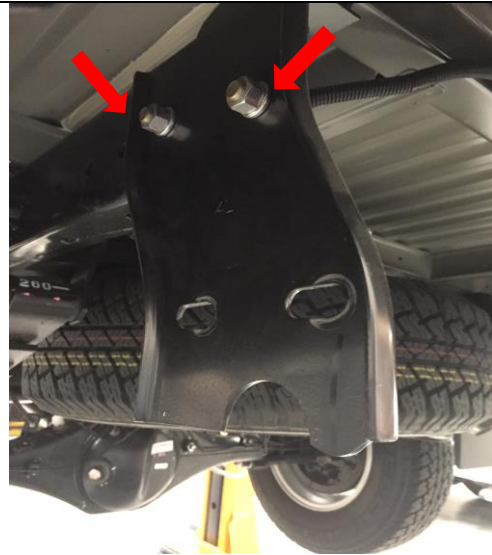

3. Lift towbar to vehicle and secure with 5 x Bolts complete with 2 x washers and 1 x nut per bolt on both the LH & RH side.

Torque all fasteners to 109Nm.

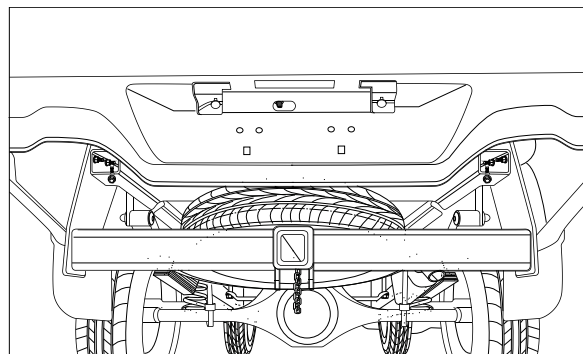

HAYMAN REESE

PART No: 03267RW

MITSUBISHI TRITON MR MY19 UTE

INSTALLATION INSTRUCTIONS

PLEASE ENSURE THAT ALL INSTRUCTIONS ARE UNDERSTOOD PRIOR TO FITMENT

PLACE THESE INSTRUCTIONS IN THE VEHICLES'S GLOVEBOX AFTER INSTALLATION IS COMPLETED

4. Refit the step to vehicle, using the existing fasteners, to the towbar sidearms.

Torque the fasteners to 50Nm.

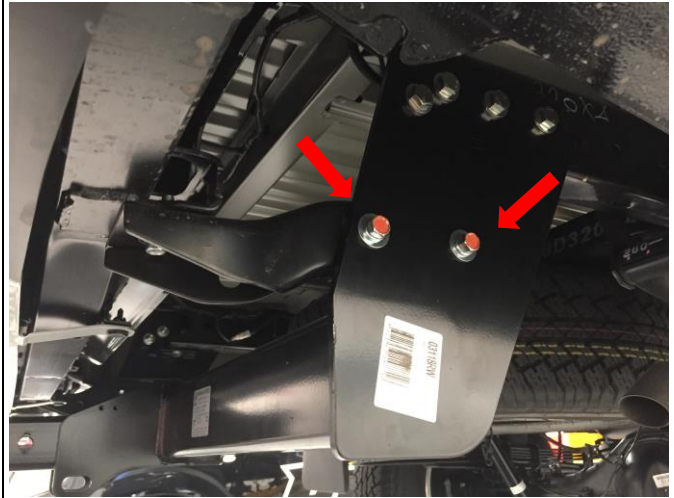

HAYMAN REESE
PART No: 102148-WL
MITSUBISHI TRITON

INSTALLATION INSTRUCTIONS

PLEASE ENSURE THAT INSTRUCTIONS ARE UNDERSTOOD PRIOR TO FITMENT

Wiring Loom Installation Instructions

MITSUBISHI TRITON

Part No: 102148-WL

Tail Harness Length Required: 1200mm

ECU - N/A

RPA Disable - N/A

**Electric Brake Input Location: Blue Wire Near Connector
Breakout**

Wiring Loom Installation Time: Approx. 15 minutes

Issue Date 01-02-19

Page 1

Part No: 102148-WL

Hayman Reese (Cequent)
PO Box 4050, Dandenong South VIC 3164
Phone 1800 812 017 Email info@haymanreese.com.au



www.haymanreese.com.au

HAYMAN REESE
PART No: 102148-WL
MITSUBISHI TRITON

INSTALLATION INSTRUCTIONS

PLEASE ENSURE THAT INSTRUCTIONS ARE UNDERSTOOD PRIOR TO FITMENT

1. In the engine bay, disconnect the negative vehicle battery cable (1).

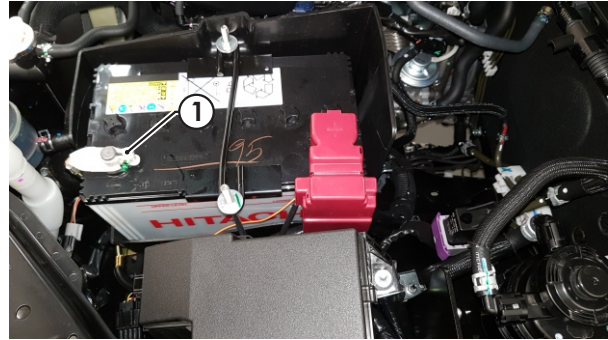

2. Under the vehicle LHS near the spare wheel, locate the vehicle black 10-way connector pair (1).

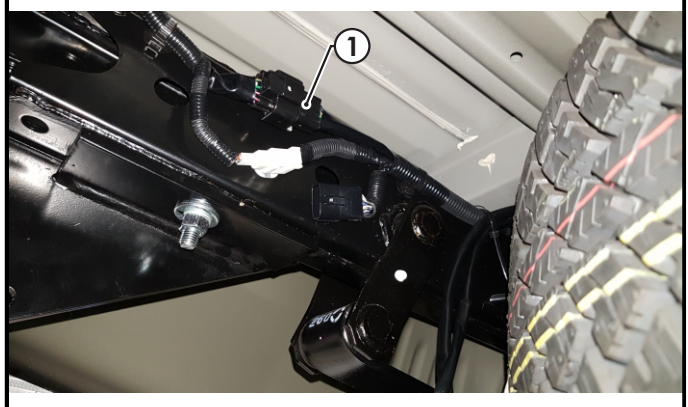

3. Disconnect the vehicle connectors and patch in the supplied Patch Harness in between the vehicle connectors.
4. Tie up excess length and waterproof relays to the existing vehicle harness.



Issue Date 01-02-19

Page 2

Part No: 102148-WL

Hayman Reese (Cequent)
PO Box 4050, Dandenong South VIC 3164
Phone 1800 812 017 Email info@haymanreese.com.au

www.haymanreese.com.au



HAYMAN REESE
PART No: 102148-WL
MITSUBISHI TRITON

INSTALLATION INSTRUCTIONS

PLEASE ENSURE THAT INSTRUCTIONS ARE UNDERSTOOD PRIOR TO FITMENT

5. Route the power and ground wire under the vehicle towards the front of the vehicle following the left hand chassis rail.
6. Route the power and ground wire up in the engine bay, towards the vehicle battery (1).

Note: Keep harness routing clear of all sharp edges, moving parts and places of extreme heat.



7. Connect the orange power wire ring terminal to the battery (1).
8. Connect the white ground wire to the vehicle earthing point (2).

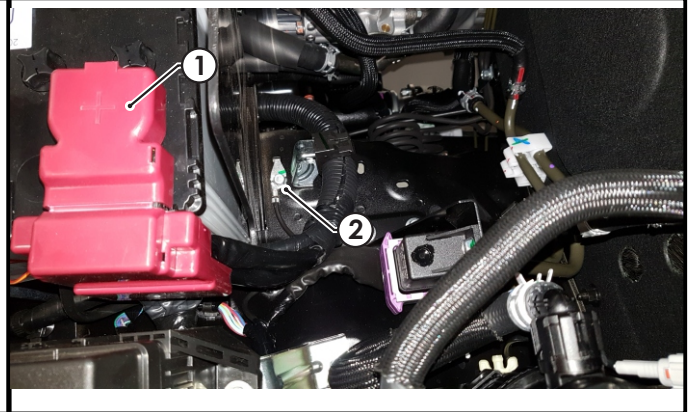

9. Secure tail harness to towbar
10. Connect the tail harness (tail length 1200mm) 8-way connector (1) to the trailer patch mating 8-way connector (2).
11. Apply silicone grease (3) (not supplied) to waterproof connector.
12. Secure all harnesses using supplied Cable Ties.
13. Test the trailer patch function using a light board or multi-meter.
15. Place the fitting instructions in the glove box after fitment.

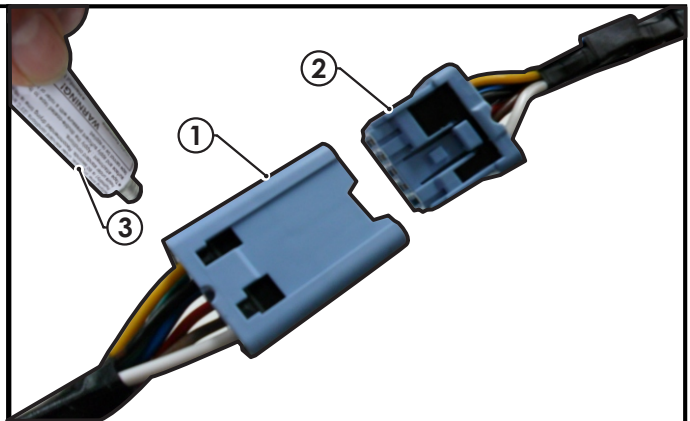

Issue Date 01-02-19

Page 3

Part No: 102148-WL

Hayman Reese (Cequent)
PO Box 4050, Dandenong South VIC 3164
Phone 1800 812 017 Email info@haymanreese.com.au

www.haymanreese.com.au





FITTING INSTRUCTIONS

Smart Pin (55070BL)

• These fitting instructions are supplied to ensure understanding of how the SMART PIN should be fitted and used correctly.

• Once installed, we recommend **ALL** instructions are kept and placed in the vehicle glove box.

NOTE: Routine maintenance and inspection of the towbar & SMART PIN is required. Regularly inspect for wear and check the tightness of the SMART PIN NUT. Follow instructions below to retighten the nut when necessary.

***Do not tow with your vehicle if the R CLIP or the SMART PIN NUT is loose or missing. Replacement parts are available from your Hayman Reese Distributor.**

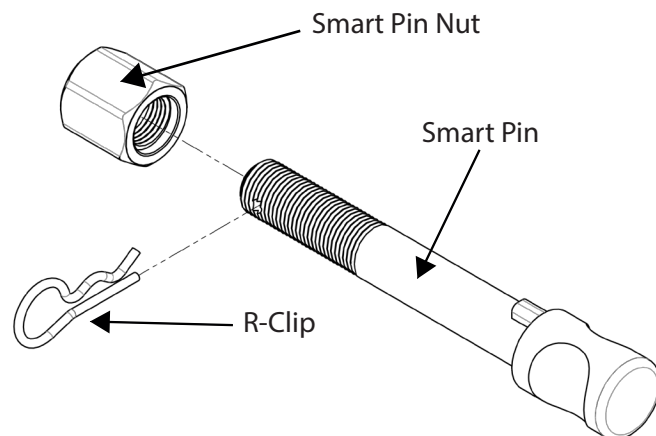
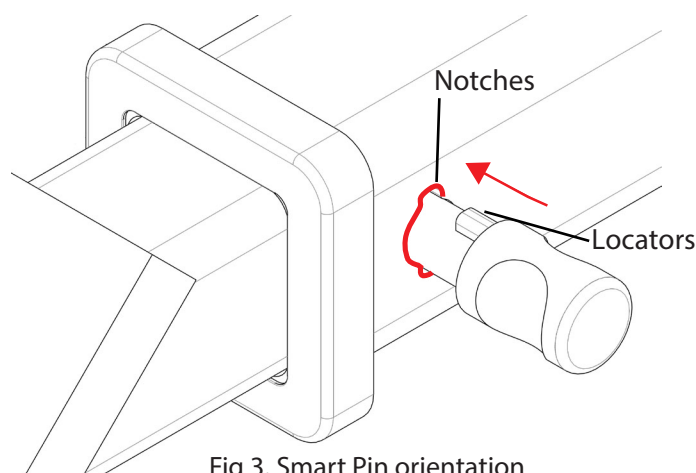
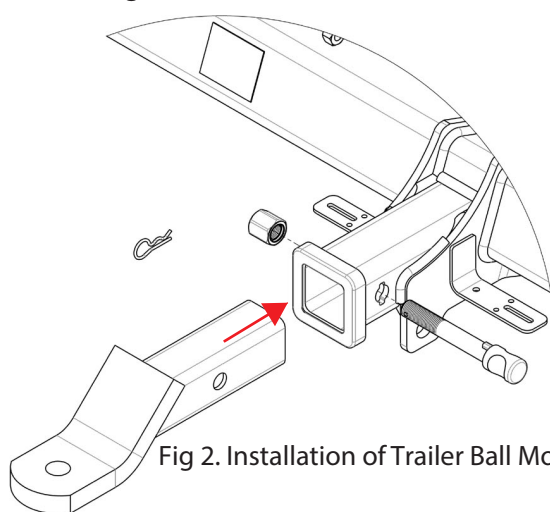

Fig 1. Smart Pin assembly

STEP 1 Insert Trailer Ball Mount (TBM) into towbar HITCHBOX, aligning hole in TBM SHANK with hole in HITCHBOX (Fig. 2).



STEP 2 Insert SMART PIN through hole in HITCHBOX and hole in TBM SHANK; ensure the LOCATORS are inserted into the NOTCHES in the HITCHBOX (Fig. 3).

STEP 3 Screw SMART PIN NUT onto SMART PIN; tighten SMART PIN NUT until finger tight, ensuring TBM is restrained from movement.

STEP 4 Tighten SMART PIN NUT by turning nut a further 1/8th of a turn in the clockwise direction using a 24mm spanner (Fig 4).

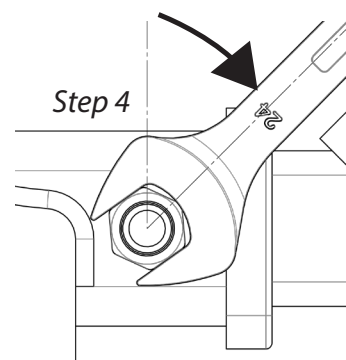

STEP 5 Install SMART PIN R CLIP through the hole on the SMART PIN (Fig. 1).

