

HAYMAN REESE
PART No: 03241RW
HOLDEN EQUINOX EQ CL4

INSTALLATION INSTRUCTIONS

PLEASE ENSURE THAT INSTRUCTIONS ARE UNDERSTOOD PRIOR TO FITMENT
PLACE THESE INSTRUCTIONS IN THE VEHICLE'S GLOVEBOX AFTER INSTALLATION IS COMPLETED



Installation Time: Approx **140**

Towbar Installation Instructions

HOLDEN EQUINOX EQ CL4

Towbar capacity

Part Number 03241RW

Max Towing Braked 2000 kg

Max Towing Unbraked 750 kg

Max Static Ball Load 200 kg

ECU: 04839

Tail Length: 1200 (Part No: 04936 if required auto disable)

RPA Disable: Near transmission lever

Electric brake input location: Near Blue connector

Hayman Reese (Cequent)
PO Box 4050, Dandenong South VIC 3164
Phone 1800 812 017 Email info@haymanreese.com.au

www.haymanreese.com.au



HAYMAN REESE
PART No: 03241RW
HOLDEN EQUINOX EQ CL4

INSTALLATION INSTRUCTIONS

PLEASE ENSURE THAT INSTRUCTIONS ARE UNDERSTOOD PRIOR TO FITMENT
PLACE THESE INSTRUCTIONS IN THE VEHICLE'S GLOVEBOX AFTER INSTALLATION IS COMPLETED

Warning:

1. Do not, drill, cut, weld or otherwise modify the towbar.
2. If you are using electric welding on a motor vehicle, **always** check that the vehicle is not equipped with electronic engine or instrument management equipment. Failure to do so could **destroy** any on board computers. If in doubt, check with the vehicle's manufacturer.
3. If TBM is used in inverted position tow ball may make contact with rear tailgate when lowered, which could cause damage.

General:

1. Ensure all hardware items have been included refer to assembly diagram.
2. It is recommended that the instructions are read through and completely understood before making any attempt to fit this product.
3. Be wary of any changes to vehicle designs or other accessories that may conflict with the installation of this product.
4. Before drilling ensure that the area is clear of fuel, electrical & other components.
5. All holes drilled into the body panels shall have all burrs & swarf removed then coated with a suitable rust preventative paint.
6. The high tensile fasteners supplied with this product were used to achieve the specified rating. If replacement is required ensure that fasteners of the same rating & quality are used. Contact an authorised **Hayman Reese** dealer if further information is required.
7. Ensure that all hardware is fastened to torque list below check fasteners on regular basis.
8. Towbar load rating sticker provided with this product shall be conspicuously located on inside rear end of the driver's door. **(See diagram below).**
9. Hayman Reese recommends that you check your tow ball to ensure that it complies with the Australian standards **AS 4177.2**.
10. **PLEASE NOTE:** It is advised to remove your LUG or TBM when not actually towing so as to produce a clear view of the vehicles registration plate if obscured, and to also provide maximum available departure angle.

Tow bar Maintenance and Care.

Hayman Reese recommends that bolt torque's, as listed below, are routinely and regularly inspected and checked for correct tension. Replace any worn or defective parts.

We recommended to remove Tow Ball Mounts (TBM's, tongues or lugs) when not being used for any considerable length of time.

So as to avoid injury, when not towing it is suggested that the tongue, Pull Pin and R-clip are removed then stored in a safe, clean and dry place, away from excessive moisture.

Hitch Pull Pins and spring "R" clips are regularly checked for proper installation. Replace any worn or defective parts.

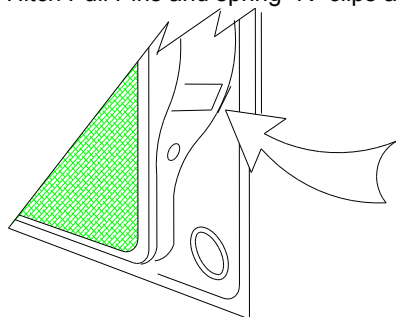

Place load rating sticker
inside driver's door here

RECOMMENDED ASSEMBLY TORQUE LISTING

Diameter Grade 8.8 Bolt

M6	9.5 Nm
M8	21.7 Nm
M10	43.4 Nm
M12	77.3 Nm
M14	146 Nm
M16	189.8 Nm

FOR TOWING PURPOSES ONLY

For towing capacity details please refer to vehicle owner's manual or to the manufacturer. Overloading can void your warranties.

Hayman Reese (Cequent)
PO Box 4050, Dandenong South VIC 3164
Phone 1800 812 017 Email info@haymanreese.com.au

www.haymanreese.com.au



HAYMAN REESE
PART No: 03241RW
HOLDEN EQUINOX EQ CL4

INSTALLATION INSTRUCTIONS

PLEASE ENSURE THAT INSTRUCTIONS ARE UNDERSTOOD PRIOR TO FITMENT
 PLACE THESE INSTRUCTIONS IN THE VEHICLE'S GLOVEBOX AFTER INSTALLATION IS COMPLETED

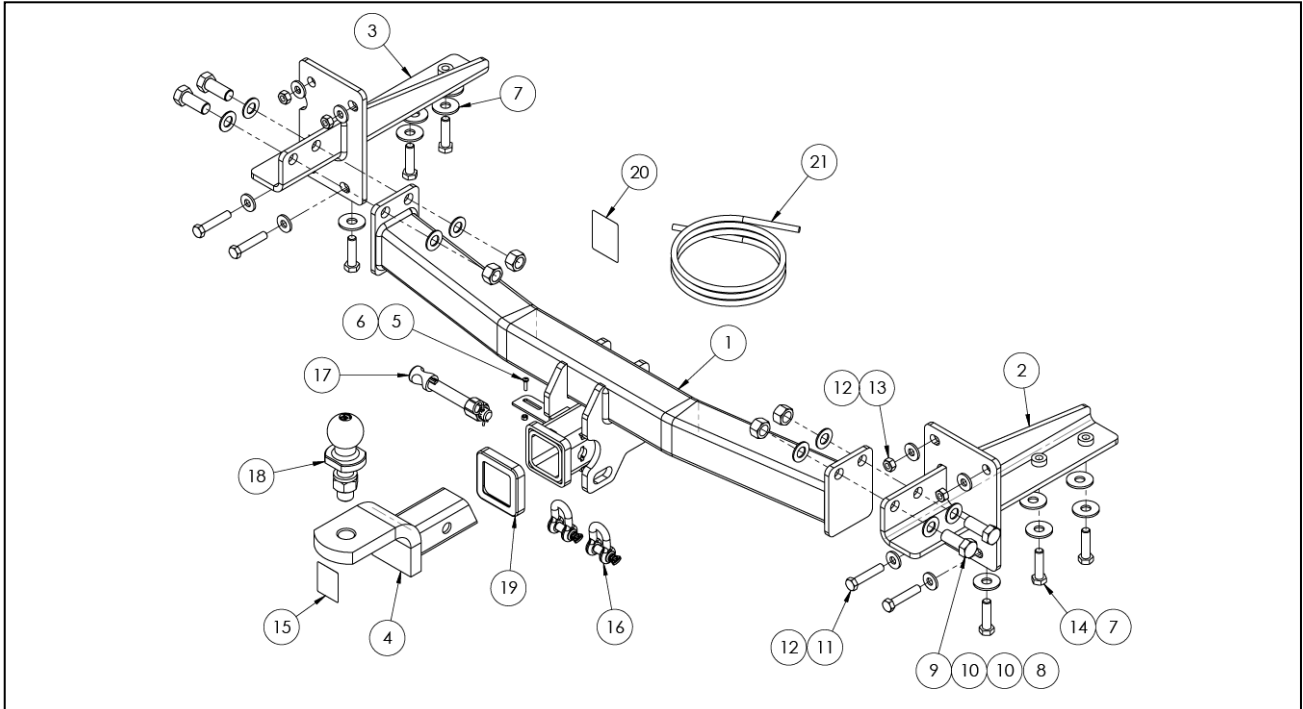

ITEM	DESCRIPTION	QTY
1	HOLDEN EQUINOX EQ CL4	1
2	HOLDEN EQUINOX RH SIDE ARM	1
3	HOLDEN EQUINOX LH SIDE ARM	1
4	TRAILER BALL MOUNT 21288	1
5	SCREW PAN HD M4 X 16 X 0.7P G4.6	2
6	NUT NYLON LOCK HEX HD M4X0.7P G8	2
7	WASHER FT M12 x 37 x 3mm	10
8	M16 NUT	4
9	M16 x 40 2.0P BOLT ZP BLACK	4
10	M16 FLAT WASHER	8
11	BOLT M10 - 1.5 x 55mm	4

ITEM	DESCRIPTION	QTY
12	WASHER PLAIN M10 X 25 X 3	8
13	HEX NUT M10x1.5	4
14	SET SCREW M12 - 1.25 x 45mm GR 8.8	6
15	H.R STICKER	1
16	10mm "D" SHACKLE	2
17	ANTI-RATTLE PULL PIN ASSY GOLD	1
18	HR TOWBALL	1
19	HITCH BOX COLLAR COVER	1
20	ACRYLIC COMPLIANCE LABEL	1
21	WIRING LOOM	1

Hayman Reese (Cequent)
 PO Box 4050, Dandenong South VIC 3164
 Phone 1800 812 017 Email info@haymanreese.com.au

www.haymanreese.com.au



HAYMAN REESE
PART No: 03241RW
HOLDEN EQUINOX EQ CL4

INSTALLATION INSTRUCTIONS

PLEASE ENSURE THAT INSTRUCTIONS ARE UNDERSTOOD PRIOR TO FITMENT
PLACE THESE INSTRUCTIONS IN THE VEHICLE'S GLOVEBOX AFTER INSTALLATION IS COMPLETED

1. Release tail-gate and remove 2 x torx head screws from either side of boot cavity.

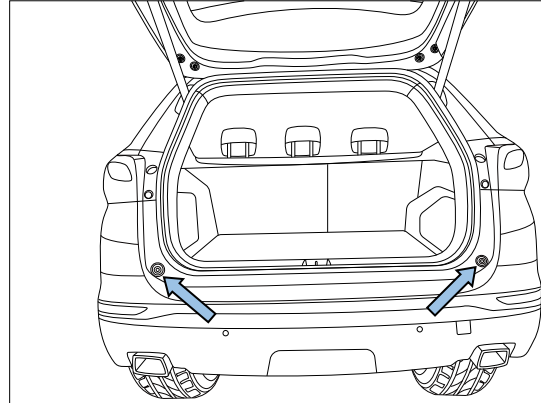

2. Remove 4 x torx head screws from inside rear wheel arch.

Repeat for opposite side.

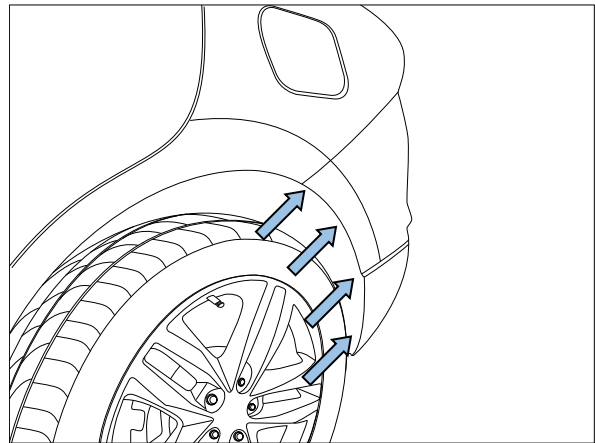

3. Remove 4 x torx head screws from underside of bumper (2 x on bumper tabs near centre of bumper; 2 x on bumper corners connected to mud flap)

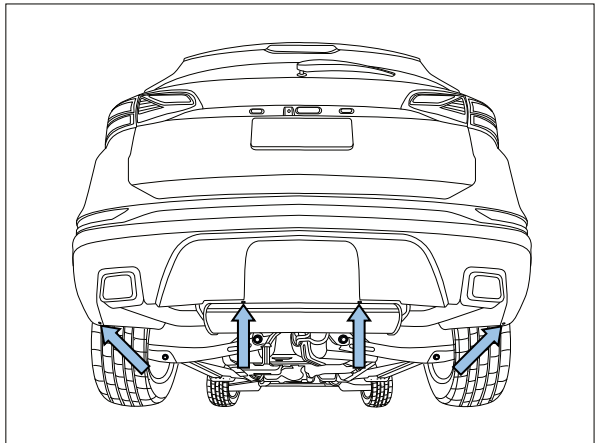

Hayman Reese (Cequent)
PO Box 4050, Dandenong South VIC 3164
Phone 1800 812 017 Email info@haymanreese.com.au

www.haymanreese.com.au



HAYMAN REESE
PART No: 03241RW
HOLDEN EQUINOX EQ CL4

INSTALLATION INSTRUCTIONS

PLEASE ENSURE THAT INSTRUCTIONS ARE UNDERSTOOD PRIOR TO FITMENT
PLACE THESE INSTRUCTIONS IN THE VEHICLE'S GLOVEBOX AFTER INSTALLATION IS COMPLETED

4. Partially pull back trim from inside rear wheel arch well to expose 1 x 7mm hex head screw connected to bumper. Remove screw.

Repeat for opposite side.

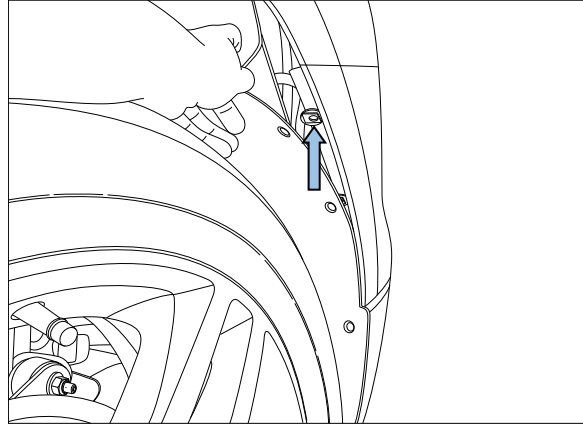

5. Carefully pry open 2 x plastic covers next to tail-light and remove 2 x torx head screw behind covers.

Pull tail-light rearwards to dislodge and disconnect any plug/s that may be attached. Set tail-light aside.

Repeat for opposite side.

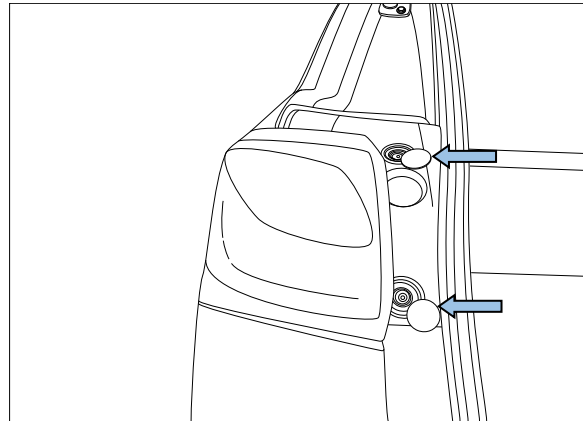

6. Carefully peel back bumper from the sides and remove.

Disconnect any attached plug/s. Set bumper aside.

Hayman Reese (Cequent)
PO Box 4050, Dandenong South VIC 3164
Phone 1800 812 017 Email info@haymanreese.com.au

www.haymanreese.com.au



HAYMAN REESE
PART No: 03241RW
HOLDEN EQUINOX EQ CL4

INSTALLATION INSTRUCTIONS

PLEASE ENSURE THAT INSTRUCTIONS ARE UNDERSTOOD PRIOR TO FITMENT
PLACE THESE INSTRUCTIONS IN THE VEHICLE'S GLOVEBOX AFTER INSTALLATION IS COMPLETED

7. Supporting the exhaust, remove 2 x lower bolts on impact beam to remove exhaust brackets.

Repeat for opposite side.

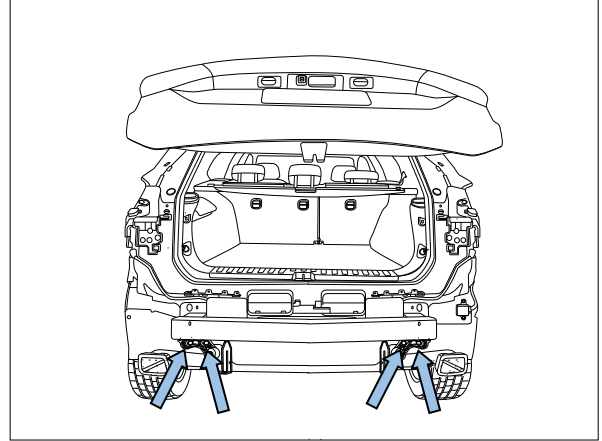

8. Remove remaining 2 x hex head bolts per side and then remove and discard impact beam and bolts.

9. Insert spacer washers into chassis rail to sit over 2 x forward most mounting holes.

10. Insert side arm into chassis rail and loosely secure to rear panel with 2 x M10 bolts and 2 x M10 nut complete with 1 x M10 washer per nut and bolt (ensure to bolt the exhaust brackets back on).

Repeat for opposite side.

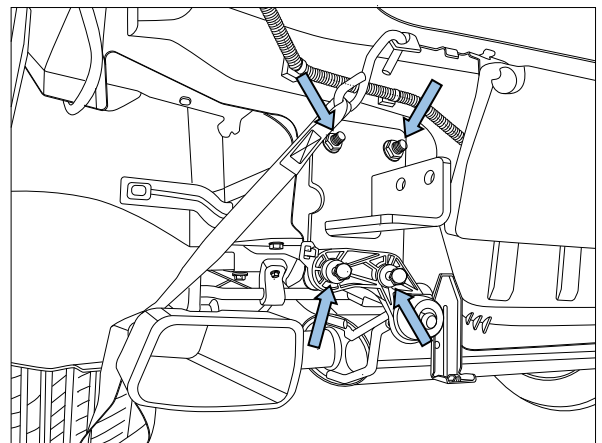

Hayman Reese (Cequent)
PO Box 4050, Dandenong South VIC 3164
Phone 1800 812 017 Email info@haymanreese.com.au

www.haymanreese.com.au



HAYMAN REESE
PART No: 03241RW
HOLDEN EQUINOX EQ CL4

INSTALLATION INSTRUCTIONS

PLEASE ENSURE THAT INSTRUCTIONS ARE UNDERSTOOD PRIOR TO FITMENT
PLACE THESE INSTRUCTIONS IN THE VEHICLE'S GLOVEBOX AFTER INSTALLATION IS COMPLETED

11. Loosely secure side arm to chassis rail with 3 x M12 bolts complete with 1 x M12 washer per bolt.

Repeat for opposite side.

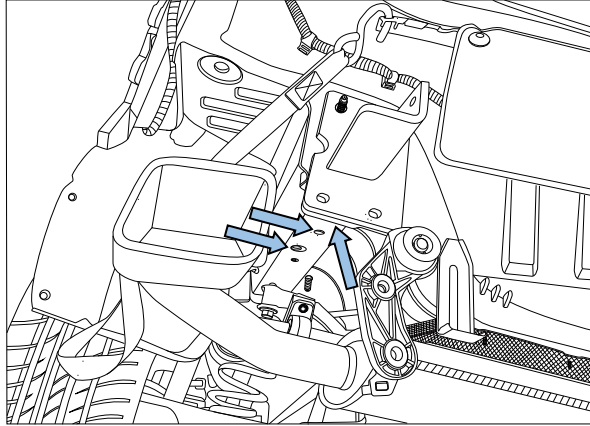

12. Using two people to lift, loosely secure the centre welded assembly to towbar side arms with 2 x M16 x 45mm bolts complete with 2 x washers and 1 x nut per bolt.

Tighten all fasteners to the torques listed below:

M16 x 8.8: 197 N.m

M12 x 8.8: 89 N.m

M10 x 8.8: 48 N.m

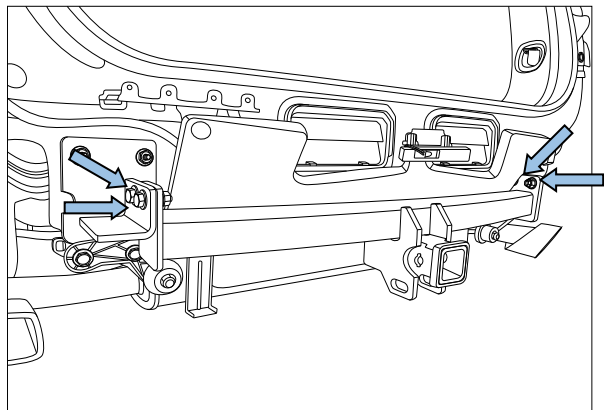

13. For Luxury models, remove 2 x torx head screws from bumper panel and unclip.

For all other models, identify the bumper centreline. Using the bumper template on the back page, mark to the specified dimension. Flip template and mark the opposite side.

Carefully cut the marked area out using an appropriate cutting tool. Remove any burrs or rough edges left after cut.

NOTE: For luxury models, bumper panel may be cut to clear exposed areas of towbar and reinstalled when not towing

Hayman Reese (Cequent)
PO Box 4050, Dandenong South VIC 3164
Phone 1800 812 017 Email info@haymanreese.com.au

www.haymanreese.com.au



HAYMAN REESE
PART No: 03241RW
HOLDEN EQUINOX EQ CL4

INSTALLATION INSTRUCTIONS

PLEASE ENSURE THAT INSTRUCTIONS ARE UNDERSTOOD PRIOR TO FITMENT
PLACE THESE INSTRUCTIONS IN THE VEHICLE'S GLOVEBOX AFTER INSTALLATION IS COMPLETED

14. In the engine bay, disconnect the negative battery.
15. In the boot, remove the solid floor liner (1) and spare wheel cover liner.
16. Remove the rear sunshade (2) and then fold down the rear seats (3).

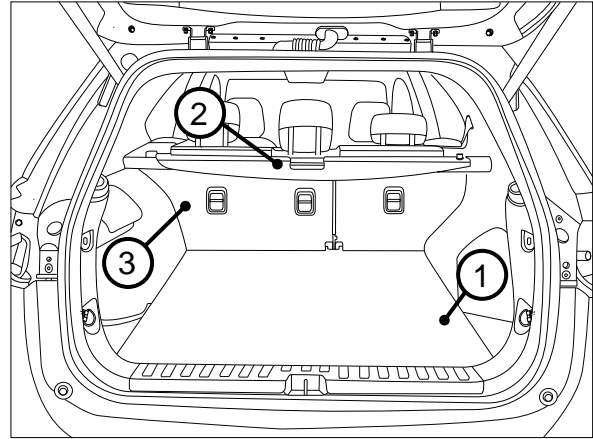

17. Using a 10mm socket, remove the 4 nuts (1) securing the middle boot liner trim (2).
18. Remove the boot liner trim and then remove the rear scuff plate (3) by pulling in an upwards direction.

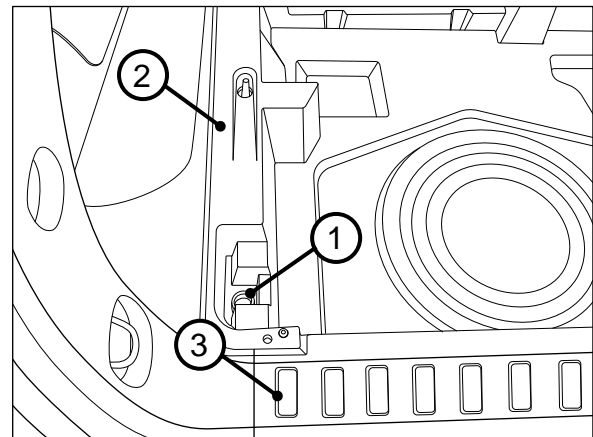

19. Using a trim removal tool, lift up the cover on the luggage securing hook and then remove the T40 Torx bolt and hook (1).

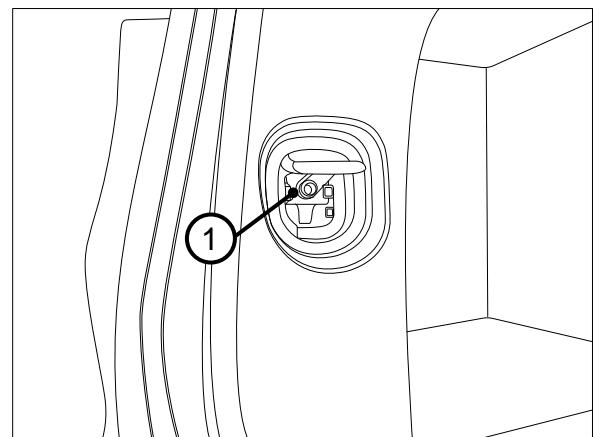

Hayman Reese (Cequent)
PO Box 4050, Dandenong South VIC 3164
Phone 1800 812 017 Email info@haymanreese.com.au

www.haymanreese.com.au



HAYMAN REESE
PART No: 03241RW
HOLDEN EQUINOX EQ CL4

INSTALLATION INSTRUCTIONS

PLEASE ENSURE THAT INSTRUCTIONS ARE UNDERSTOOD PRIOR TO FITMENT
PLACE THESE INSTRUCTIONS IN THE VEHICLE'S GLOVEBOX AFTER INSTALLATION IS COMPLETED

20. Remove the large trim clip above the luggage hook (1).
21. Dislodge the LHS Trim (2) to gain access to the Grey CAN connector.

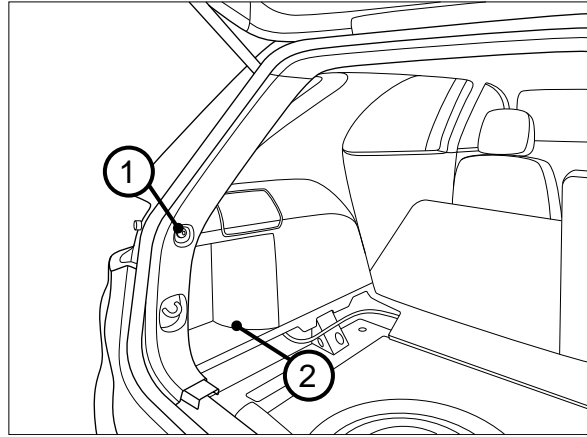

22. Carefully remove the tape from the connector and plug it into the Grey connector on the patch harness (1).

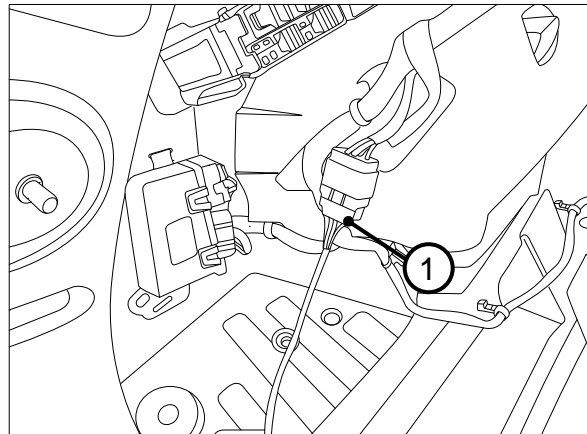

23. Using an alcohol wipe, clean the LHS inner sheet metal area (1) and the underside of the ECU (04839) (2).
24. Connect the trailer patch black 22-way connector (3) to the ECU.
25. Apply double sided tape to the ECU (2) and secure it to the vehicle sheet metal, ensuring the connector is facing down.

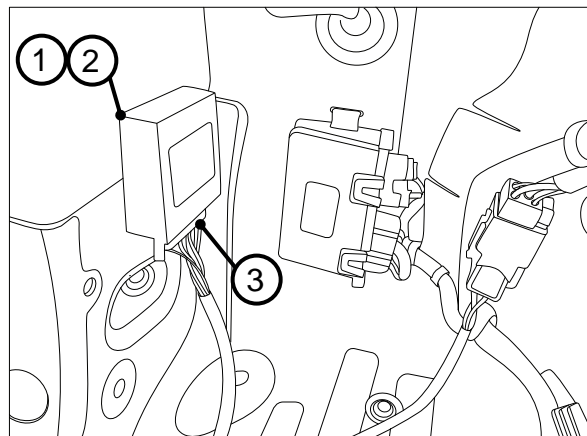

Hayman Reese (Cequent)
PO Box 4050, Dandenong South VIC 3164
Phone 1800 812 017 Email info@haymanreese.com.au

www.haymanreese.com.au



HAYMAN REESE
PART No: 03241RW
HOLDEN EQUINOX EQ CL4

INSTALLATION INSTRUCTIONS

PLEASE ENSURE THAT INSTRUCTIONS ARE UNDERSTOOD PRIOR TO FITMENT
PLACE THESE INSTRUCTIONS IN THE VEHICLE'S GLOVEBOX AFTER INSTALLATION IS COMPLETED

26. Locate the 20mm blanking grommet (1).
27. Remove and discard.
28. Drill out hole to 30mm to enable the tail harness (04936) to be routed from the towbar to the patch harness.

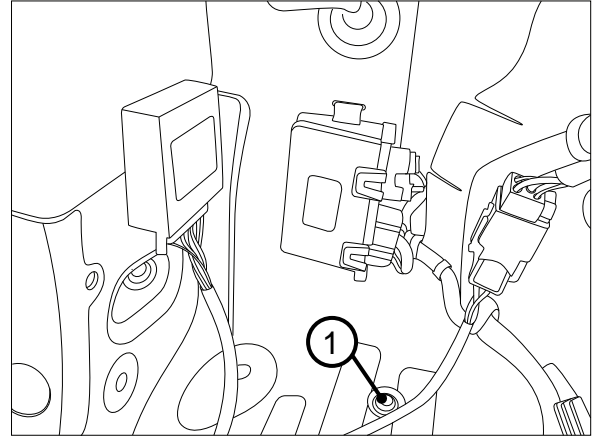

29. With the rear bumper removed, secure tail harness (1) to towbar.
30. Route tail harness (1) up through chassis rail and previously removed vehicle blanking grommet.
31. Seat grommet in 30mm blanking hole and route to trailer harness blue connector on wiring loom.

Note: keep harness routing clear of all sharp edges, moving parts and places of extreme heat.

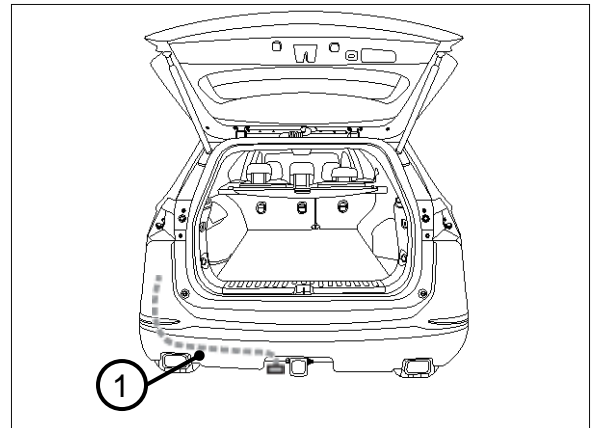

32. Connect the tail harness (tail length 1200mm) 8-way connector (1) to the trailer patch mating 8-way connector (2) and tie up excess length.
Note: Avoiding tying excess lengths which will hinder putting the panel back on.

33. Connect wires with crimp, GREY (3) and GREY/Black (4) wires to the RPA patch matching GREY (5) and WHITE (6) wires and insulate connections.

34. The RPA can be disabled via a button near the transmission lever.

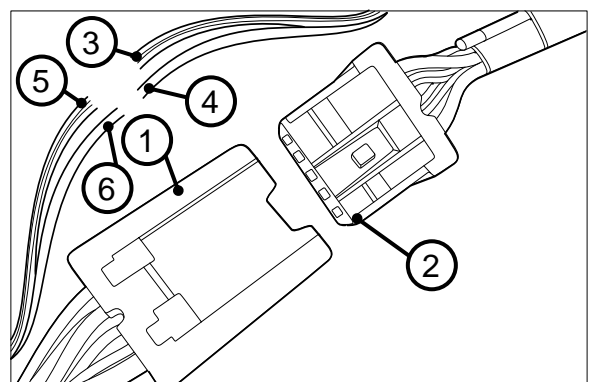

Hayman Reese (Cequent)
PO Box 4050, Dandenong South VIC 3164
Phone 1800 812 017 Email info@haymanreese.com.au

www.haymanreese.com.au



HAYMAN REESE
PART No: 03241RW
HOLDEN EQUINOX EQ CL4

INSTALLATION INSTRUCTIONS

PLEASE ENSURE THAT INSTRUCTIONS ARE UNDERSTOOD PRIOR TO FITMENT
PLACE THESE INSTRUCTIONS IN THE VEHICLE'S GLOVEBOX AFTER INSTALLATION IS COMPLETED

<p>35. Test the trailer patch function using a light board or multi-meter.</p> <p>36. Secure all harness using cable ties (not supplied).</p> <p>37. Re-fit all removed parts and secure all fasteners, ensuring there are no squeaks or rattles.</p> <p>38. Place the fitting instructions in the glove box after fitment.</p>	
<p>39. Re-fit all components to vehicle following steps 1-7 in reverse.</p> <p>Attach trailer plug to plug bracket welded onto towbar.</p>	

Hayman Reese (Cequent)
PO Box 4050, Dandenong South VIC 3164
Phone 1800 812 017 Email info@haymanreese.com.au

www.haymanreese.com.au



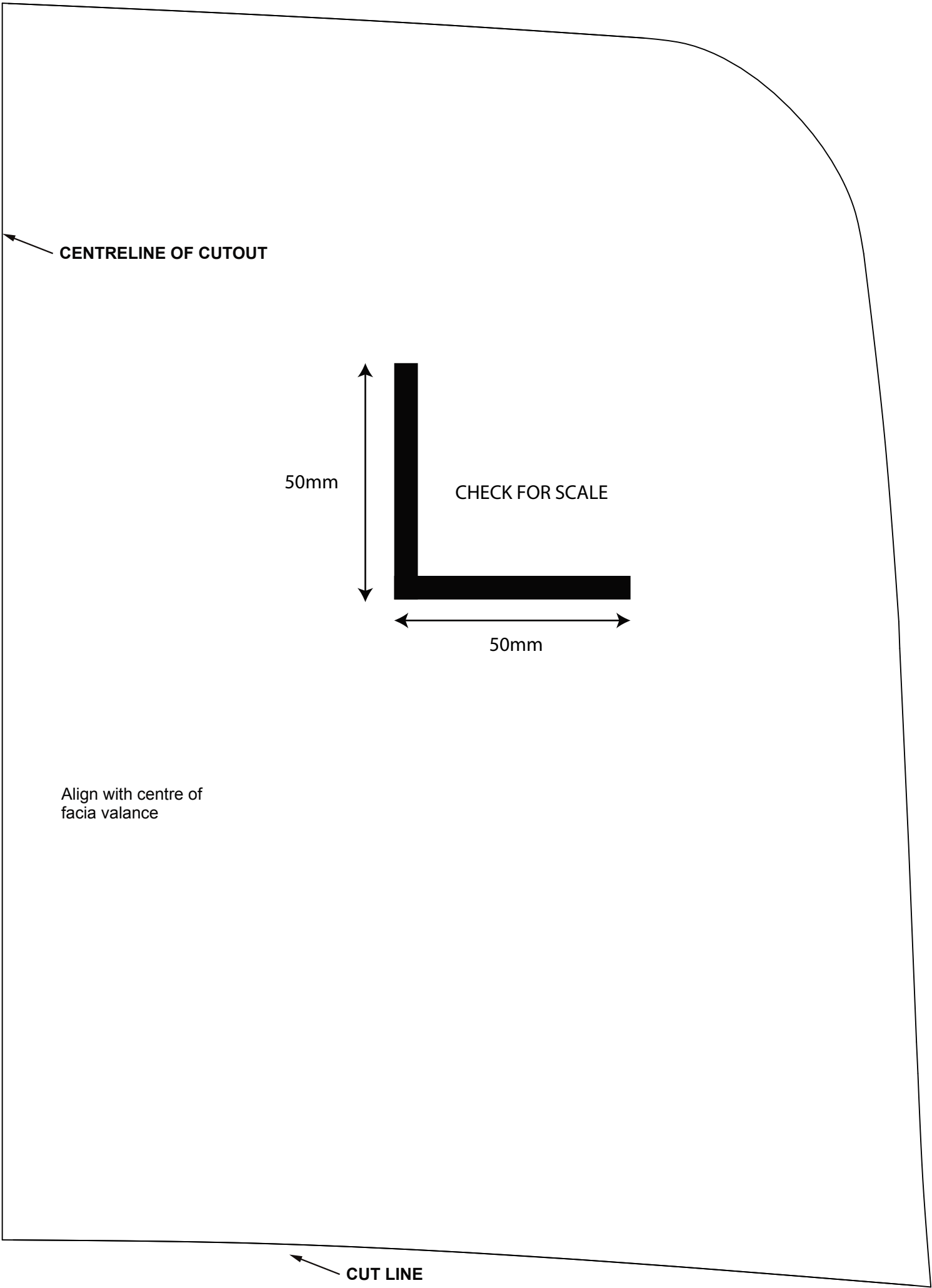

CENTRELINE OF CUTOUT

50mm

CHECK FOR SCALE

50mm

Align with centre of
facia valance

CUT LINE

BUMPER CUT TEMPLATE



FITTING INSTRUCTIONS

Smart Pin (55070BL)

• These fitting instructions are supplied to ensure understanding of how the SMART PIN should be fitted and used correctly.

• Once installed, we recommend **ALL** instructions are kept and placed in the vehicle glove box.

NOTE: Routine maintenance and inspection of the towbar & SMART PIN is required. Regularly inspect for wear and check the tightness of the SMART PIN NUT. Follow instructions below to retighten the nut when necessary.

***Do not tow with your vehicle if the R CLIP or the SMART PIN NUT is loose or missing. Replacement parts are available from your Hayman Reese Distributor.**

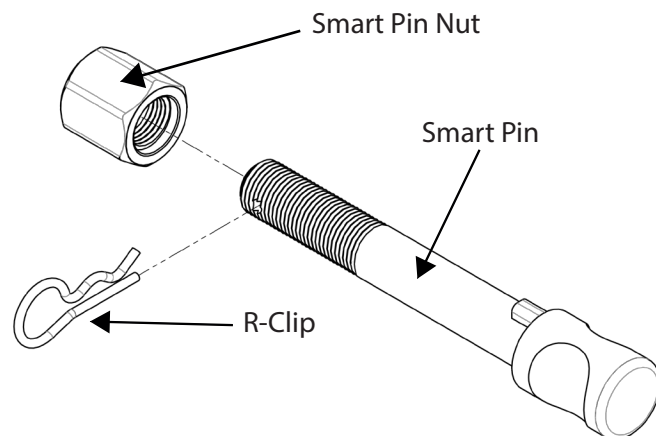
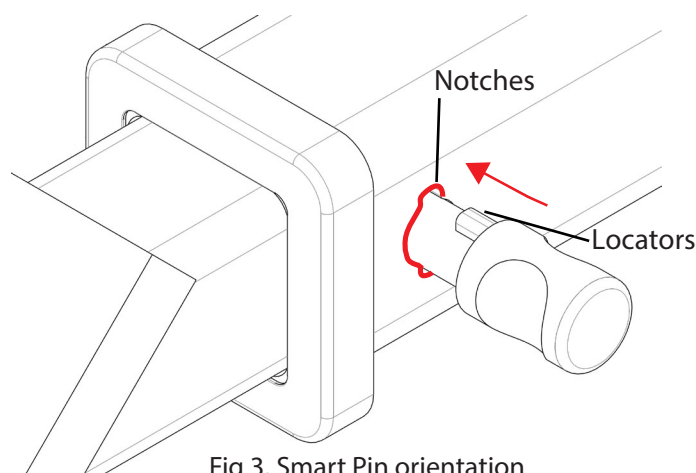
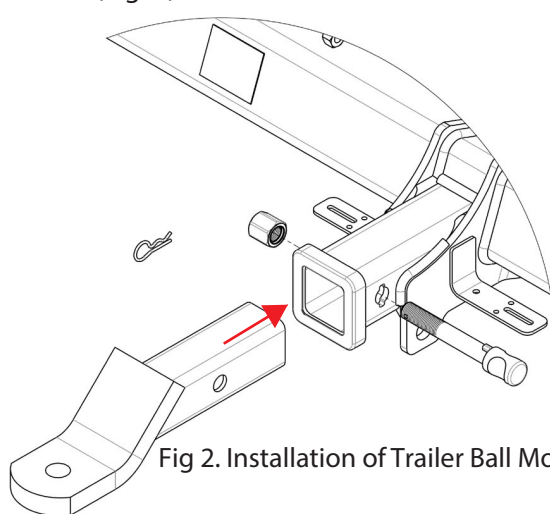

Fig 1. Smart Pin assembly

STEP 1 Insert Trailer Ball Mount (TBM) into towbar HITCHBOX, aligning hole in TBM SHANK with hole in HITCHBOX (Fig. 2).



STEP 2 Insert SMART PIN through hole in HITCHBOX and hole in TBM SHANK; ensure the LOCATORS are inserted into the NOTCHES in the HITCHBOX (Fig. 3).

STEP 3 Screw SMART PIN NUT onto SMART PIN; tighten SMART PIN NUT until finger tight, ensuring TBM is restrained from movement.

STEP 4 Tighten SMART PIN NUT by turning nut a further 1/8th of a turn in the clockwise direction using a 24mm spanner (Fig 4).

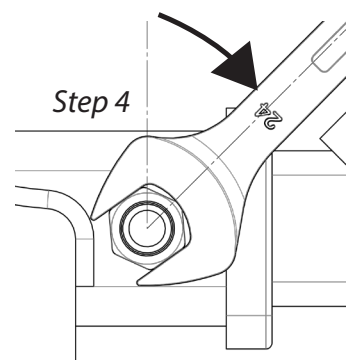

STEP 5 Install SMART PIN R CLIP through the hole on the SMART PIN (Fig. 1).

