

HAYMAN REESE
PART No: 03140RW
KIA SORENTO MY15
INSTALLATION INSTRUCTIONS

PLEASE ENSURE THAT ALL INSTRUCTIONS ARE UNDERSTOOD PRIOR TO FITMENT
PLACE THESE INSTRUCTIONS IN THE VEHICLE'S GLOVEBOX AFTER INSTALLATION IS COMPLETED



Installation Time: Approx 90 Mins

Towbar Installation Instructions

Towbar capacity

KIA UM SORENTO MY15

Part Number 03140RW	Max Towing Braked	2000 kg
	Max Towing Unbraked	750 kg
	Max Static Ball Load	100 kg

Hayman Reese (Cequent)
PO Box 4050, Dandenong South VIC 3164
Phone 1800 812 017 Email info@haymanreese.com.au

HAYMAN REESE
PART No: 03140RW
KIA UM SORENTO MY15
INSTALLATION INSTRUCTIONS

PLEASE ENSURE THAT ALL INSTRUCTIONS ARE UNDERSTOOD PRIOR TO FITMENT
PLACE THESE INSTRUCTIONS IN THE VEHICLES'S GLOVEBOX AFTER INSTALLATION IS COMPLETED

Warning:

1. Do not, drill, cut, weld or otherwise modify the towbar.
2. If you are using electric welding on a motor vehicle, **always** check that the vehicle is not equipped with electronic engine or instrument management equipment. Failure to do so could **destroy** any onboard computers. If in doubt, check with the vehicle's manufacturer.
3. If TBM is used in inverted position tow ball may make contact with rear tailgate when lowered, which could cause damage.

General:

1. Ensure all hardware items have been included refer to assembly diagram.
2. It is recommended that the instructions are read through and completely understood before making any attempt to fit this product.
3. Be wary of any changes to vehicle designs or other accessories that may conflict with the installation of this product.
4. Before drilling ensure that the area is clear of fuel, electrical & other components.
5. All holes drilled into the body panels shall have all burrs & swarf removed then coated with a suitable rust preventative paint.
6. The high tensile fasteners supplied with this product were used to achieve the specified rating. If replacement is required ensure that fasteners of the same rating & quality are used. Contact an authorised **Hayman Reese** dealer if further information is required.
7. Ensure that all hardware is fastened to torque list below check fasteners on regular basis.
8. Towbar load rating sticker provided with this product shall be conspicuously located on inside rear end of the driver's door. **(See diagram below).**
9. Hayman Reese recommends that you check your tow ball to ensure that it complies with the Australian standards **AS 4177.2**.
10. **PLEASE NOTE:** It is advised to remove your lug or tbn when not actually towing so as to produce a clear view of the vehicles registration plate if obscured, and to also provide maximum available departure angle.
11. Pull Pin must be fit in down position.

Tow bar Maintenance and Care.

Hayman Reese recommends that bolt torque's, as listed below, are routinely and regularly inspected and checked for correct tension. Replace any worn or defective parts.

We recommended to remove Tow Ball Mounts (TBM's, tongues or lugs) when not being used for any considerable length of time.

So as to avoid injury, when not towing it is suggested that the tongue, Pull Pin and R-clip are removed then stored in a safe, clean and dry place, away from excessive moisture.

Hitch Pull Pins and spring "R" clips are regularly checked for proper installation. Replace any worn or defective parts.

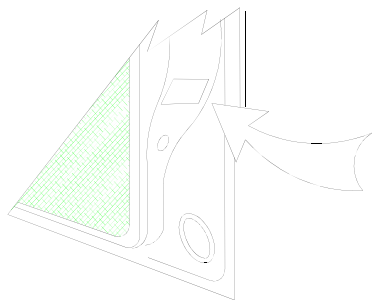

**Place load rating sticker
inside driver's door here**

FOR TOWING PURPOSES ONLY
For towing capacity details please refer to vehicle
owner's manual or to the manufacturer. Overloading can
void your warranties.

HAYMAN REESE
PART No: 03140RW
KIA UM SORENTO MY15
INSTALLATION INSTRUCTIONS

PLEASE ENSURE THAT ALL INSTRUCTIONS ARE UNDERSTOOD PRIOR TO FITMENT
 PLACE THESE INSTRUCTIONS IN THE VEHICLES'S GLOVEBOX AFTER INSTALLATION IS COMPLETED

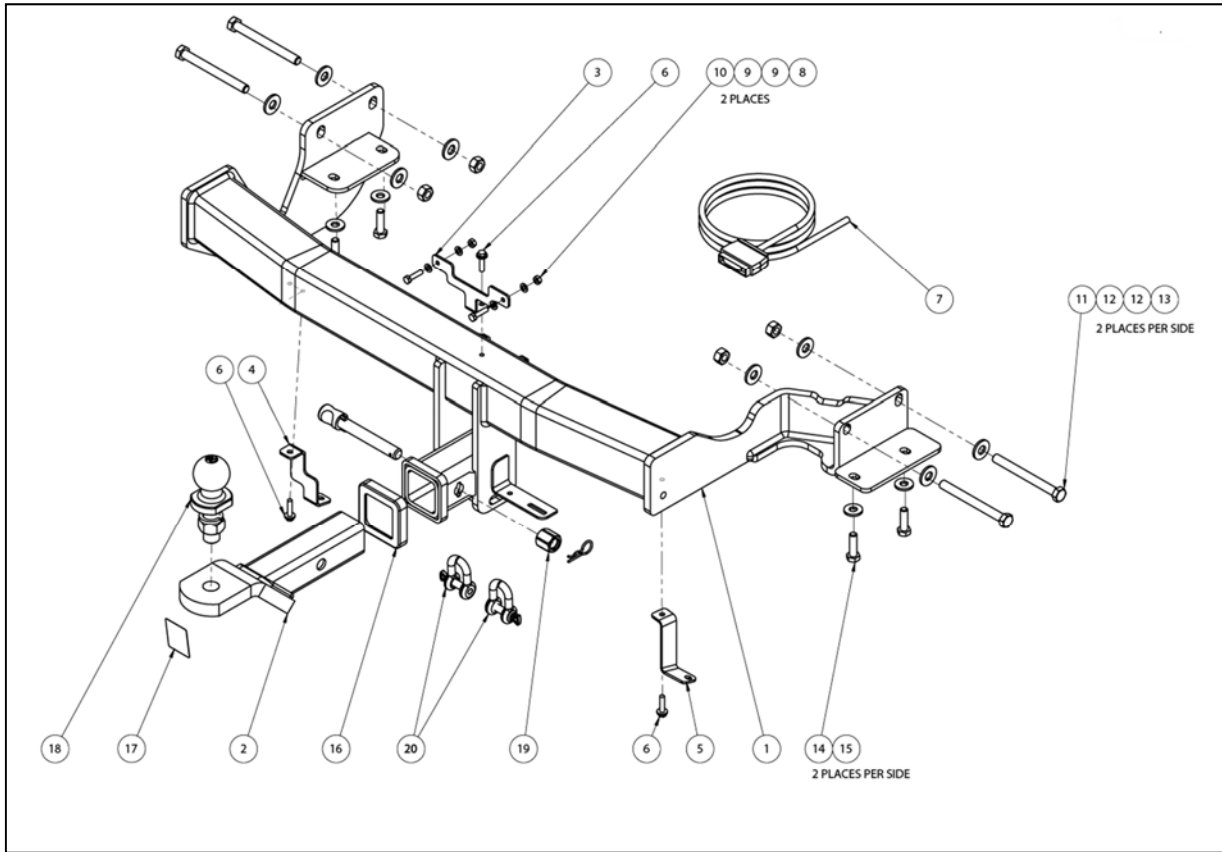

QTY.	DESCRIPTION	ITEM NO.
1	KIA SORENTO WELDED ASSEMBLY	1
1	T.B.MOUNT ASSEMBLY	2
1	SMART KEY ANTENNA BRACKET	3
1	LHS BUMPER BRACKET	4
1	RHS BUMPER BRACKET	5
3	TEK SCREW	6
1	VEHICLE -TRAILER WIRING HARNESS	7
2	SET SCREW M6x25x1P	8
4	WASHER FLAT M6x12.5x1.2	9
2	NYLOC NUT M6-1P	10
4	BOLT HEX HD M12x120x1.25P GR10.9	11
8	WASHER FLAT M12	12
4	HEX NUT M12 M12x1.25P	13
4	SET SCREW M10x35x1.25P	14
4	WASHER FLAT M10x25.4x3	15
1	HITCH BOX COLLAR COVER	16
1	H.R STICKER	17
1	HR TOWBALL	18
1	ANTI-RATTLE PULL PIN ASSY GOLD	19
2	10mm "D" SHACKLE	20
1	HR ADR LABEL	21

HAYMAN REESE
PART No: 03140RW
KIA UM SORENTO MY15
INSTALLATION INSTRUCTIONS

PLEASE ENSURE THAT ALL INSTRUCTIONS ARE UNDERSTOOD PRIOR TO FITMENT
PLACE THESE INSTRUCTIONS IN THE VEHICLES'S GLOVEBOX AFTER INSTALLATION IS COMPLETED

1. Open the rear tailgate.

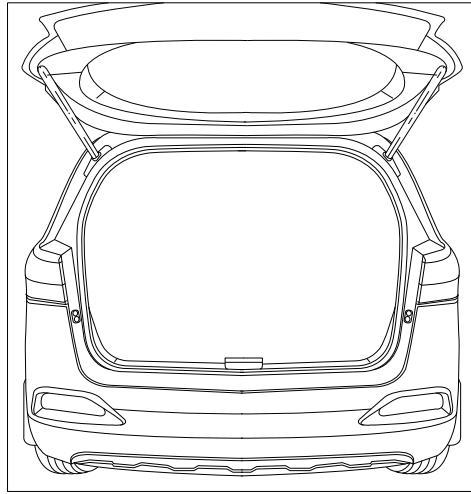

2. Remove 2 Screws and disconnect the RHS taillight connector from inside the vehicle boot.

Dislodge the RHS taillight.

Repeat for LHS.

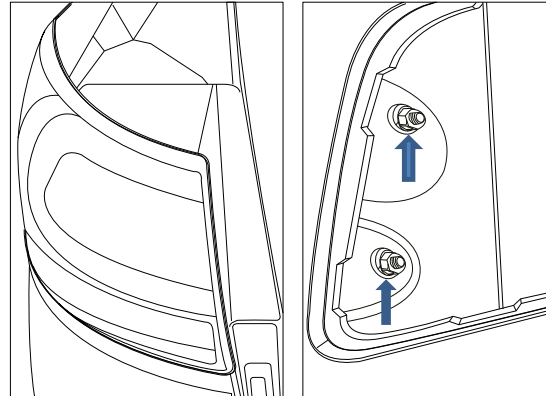

3. Remove 2 Scrivets located in the RHS taillight bumper cavity.

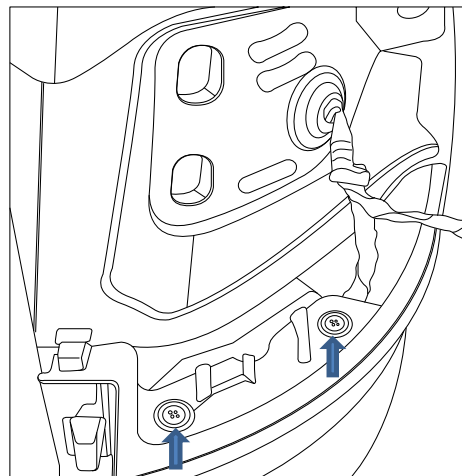

HAYMAN REESE
PART No: 03140RW
KIA UM SORENTO MY15
INSTALLATION INSTRUCTIONS

PLEASE ENSURE THAT ALL INSTRUCTIONS ARE UNDERSTOOD PRIOR TO FITMENT
PLACE THESE INSTRUCTIONS IN THE VEHICLES'S GLOVEBOX AFTER INSTALLATION IS COMPLETED

4. Remove 4 screws and 1 scrivet in the RHS wheel arch.

Repeat for LHS.

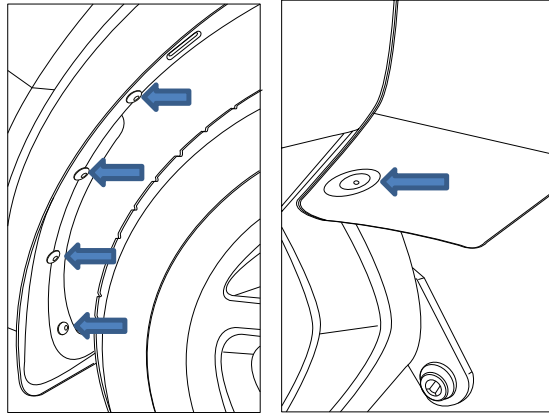

5. Remove 3 scrivets from the RHS underside protection located on the underside of the bumper.

Repeat for LHS.

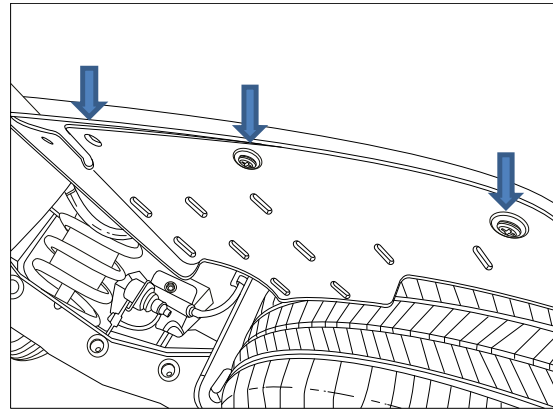

6. Remove 3 bolts from the RHS of the intrusion beam.

Repeat for LHS.

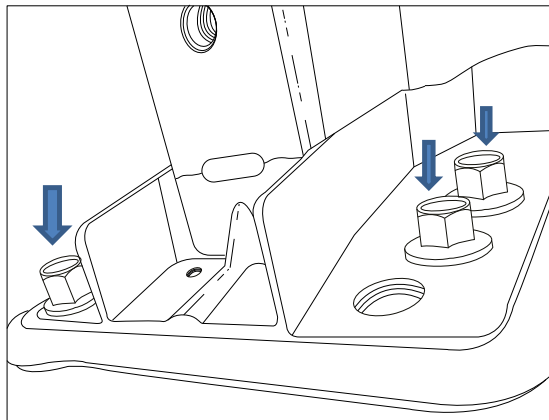

HAYMAN REESE
PART No: 03140RW
KIA UM SORENTO MY15
INSTALLATION INSTRUCTIONS

PLEASE ENSURE THAT ALL INSTRUCTIONS ARE UNDERSTOOD PRIOR TO FITMENT
PLACE THESE INSTRUCTIONS IN THE VEHICLES'S GLOVEBOX AFTER INSTALLATION IS COMPLETED

7. Drop the rear tyre.

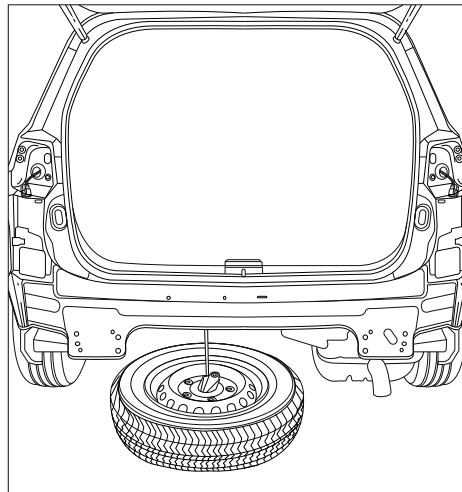

8. Remove 2 flange nuts securing the exhaust shield on the RHS, and set aside.

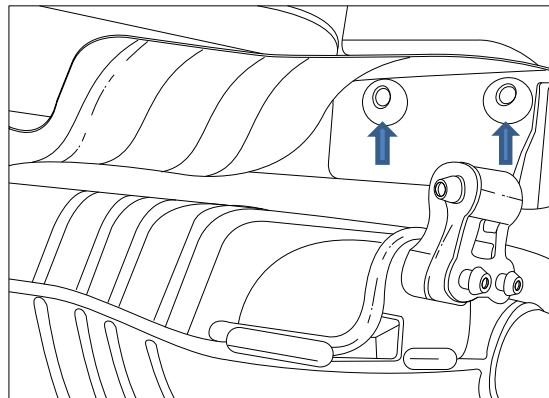

9. Offer the towbar to the vehicle via the outside of the LHS chassis rail and inside of the RHS chassis rail.

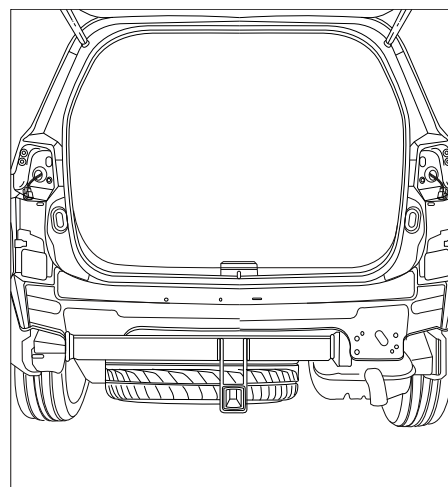

HAYMAN REESE
PART No: 03140RW
KIA UM SORENTO MY15
INSTALLATION INSTRUCTIONS

PLEASE ENSURE THAT ALL INSTRUCTIONS ARE UNDERSTOOD PRIOR TO FITMENT
PLACE THESE INSTRUCTIONS IN THE VEHICLES'S GLOVEBOX AFTER INSTALLATION IS COMPLETED

10. Insert 2x M12 bolts into the LHS of the chassis rail.

Repeat for RHS.

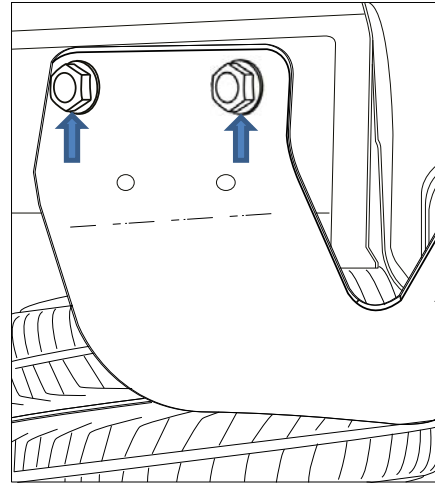

11. Insert 2x M10 bolts from the underside of the chassis rail.

Repeat for RHS.

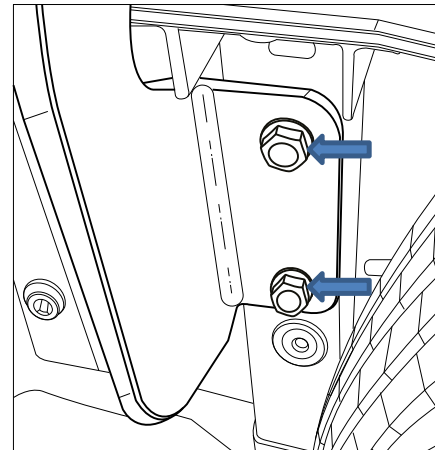

12. Torque bolts to the following specifications:

- M12x1.25P GR10.9 = 129Nm
- M10x1.25P GR8.8 = 55Nm

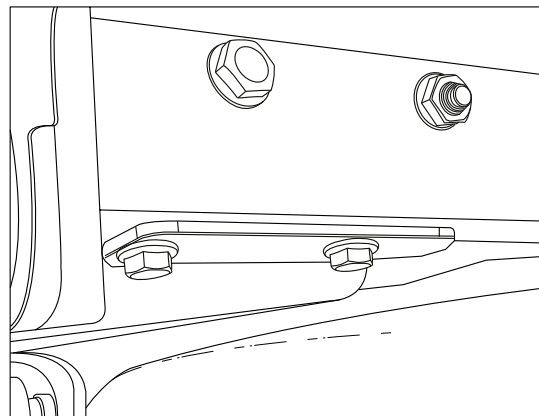

HAYMAN REESE
PART No: 03140RW
KIA UM SORENTO MY15
INSTALLATION INSTRUCTIONS

PLEASE ENSURE THAT ALL INSTRUCTIONS ARE UNDERSTOOD PRIOR TO FITMENT
PLACE THESE INSTRUCTIONS IN THE VEHICLES'S GLOVEBOX AFTER INSTALLATION IS COMPLETED

13. Perform a bumper cut as per the attached template on the last page of these fitting instructions.

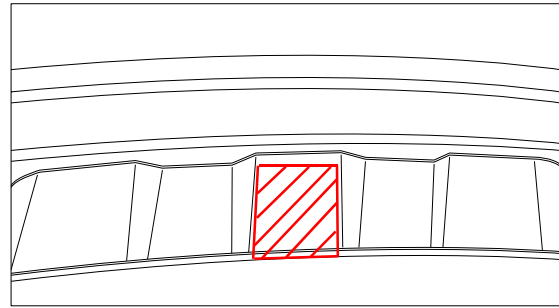

14. Cut the exhaust shield as shown in the image, and discard the lower section as shown.

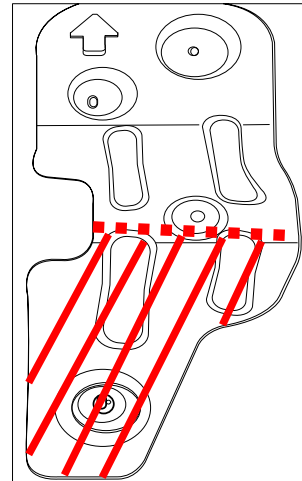

15. Refit the exhaust shield to the vehicle using one flange nut.
16. Tek screw the smart key antenna bracket supplied to the towbar and fit the smart key antenna to the bracket.
17. Refit the bumper and all removed parts to the vehicle.

HAYMAN REESE

PART No: 03140RW

KIA SORENTO

INSTALLATION INSTRUCTIONS

PLEASE ENSURE THAT ALL INSTRUCTIONS ARE UNDERSTOOD PRIOR TO FITMENT
PLACE THESE INSTRUCTIONS IN THE VEHICLES'S GLOVEBOX AFTER INSTALLATION IS COMPLETED

KIA SORENTO BUMPER CUT TEMPLATE

1. CHECK THE TEMPLATE IS TO SCALE.
2. FIND THE CENTRE OF THE BUMPER.
3. ALIGN THE CENTRELINE OF THE TEMPLATE WITH THE CENTRE OF THE BUMPER.
4. DRILL OUT THE TWO 20mm HOLES.
5. CUT ALONG THE DOTTED LINES.

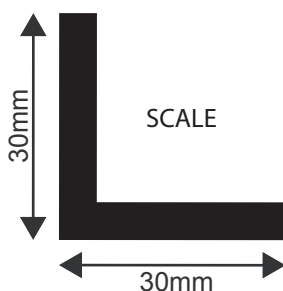

NOTE: MEASURE THE TEMPLATE TO CHECK IF TO SCALE

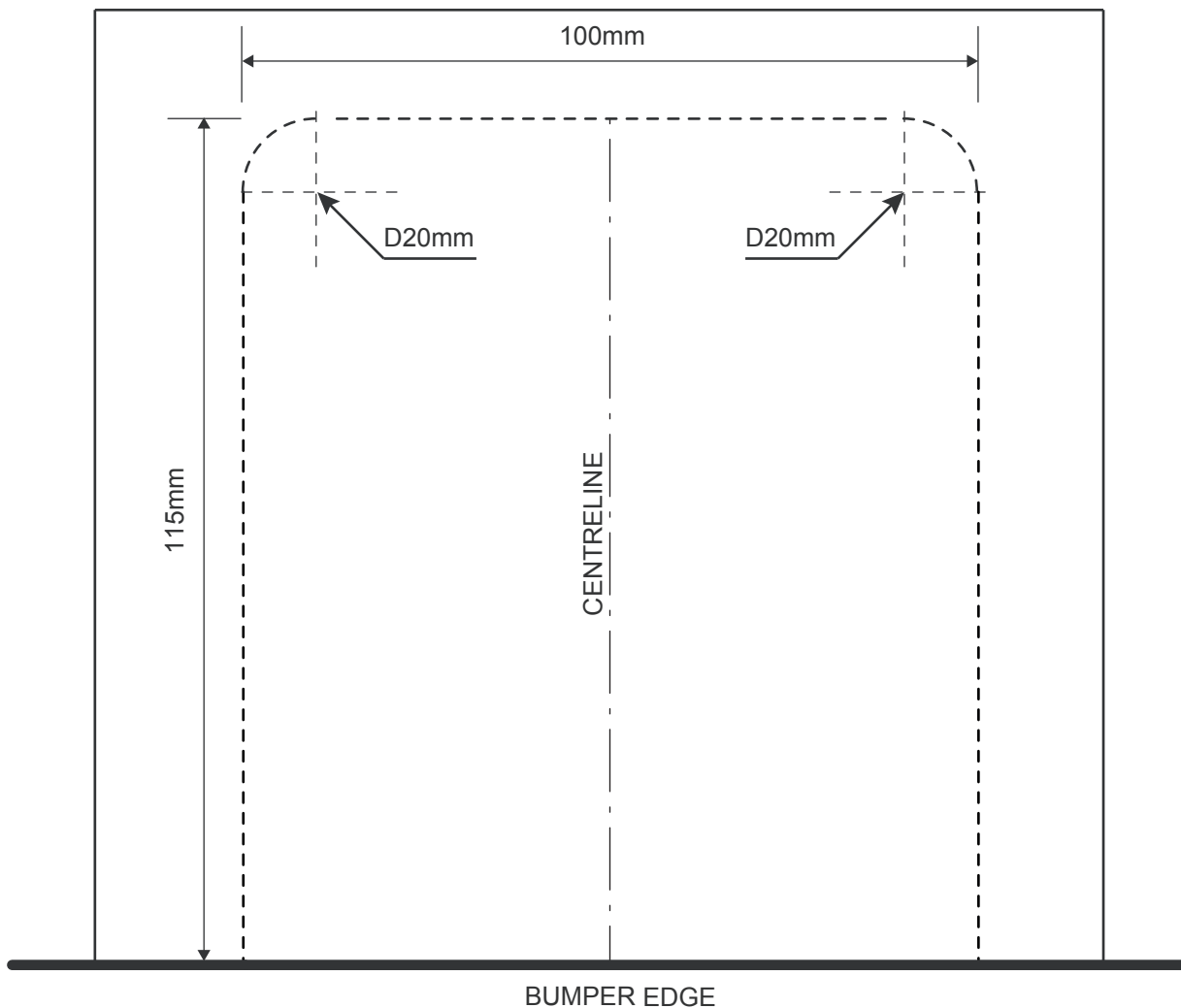

HAYMAN REESE
PART No: 100873-WL
KIA SORENTO MY12 ONWARDS

INSTALLATION INSTRUCTIONS

PLEASE ENSURE THAT INSTRUCTIONS ARE UNDERSTOOD PRIOR TO FITMENT

Wiring Loom Installation Instructions
KIA SORENTO MY12 ONWARDS

Part No: 100873-WL
ECU Required: 04835

Tail Harness Length Required: 400mm

Wiring Loom Installation Time: Approx. 40 minutes

Issue Date 13-08-15

Page 1

Part No: 100873-WL

Hayman Reese (Cequent)
PO Box 4050, Dandenong South VIC 3164
Phone 1800 812 017 Email info@haymanreese.com.au

www.haymanreese.com.au



HAYMAN REESE
PART No: 100873-WL
KIA SORENTO MY12 ONWARDS

INSTALLATION INSTRUCTIONS

PLEASE ENSURE THAT INSTRUCTIONS ARE UNDERSTOOD PRIOR TO FITMENT

All steps are suitable for all MY12 and onwards models unless otherwise specified.

1. Remove the rear bumper fascia by removing all the fasteners.
2. In the luggage compartment, remove the tool compartment carpet cover (1).



3. Remove the rear luggage compartment trim (1) by removing the three screws (2).

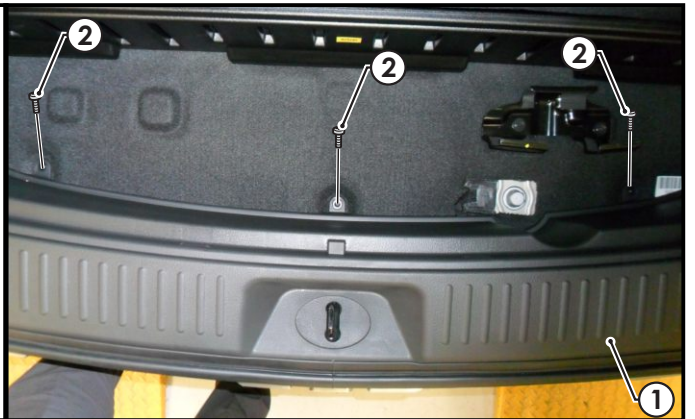

4. On the LHS of the luggage compartment, remove the screw (1) and remove the access panel (2).
5. Dislodge the LHS luggage compartment trim (3).

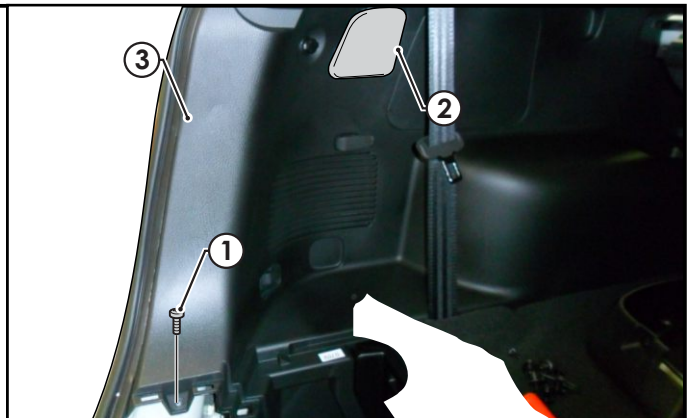

Issue Date 13-08-15

Page 2

Part No: 100873-WL

Hayman Reese (Cequent)
PO Box 4050, Dandenong South VIC 3164
Phone 1800 812 017 Email info@haymanreese.com.au

www.haymanreese.com.au



HAYMAN REESE
PART No: 100873-WL
KIA SORENTO MY12 ONWARDS

INSTALLATION INSTRUCTIONS

PLEASE ENSURE THAT INSTRUCTIONS ARE UNDERSTOOD PRIOR TO FITMENT

This step for MY15 models only:

6. Remove the upper (1) and lower 'C' pillar fastener (2) and then remove the upper 'C' pillar trim (3).

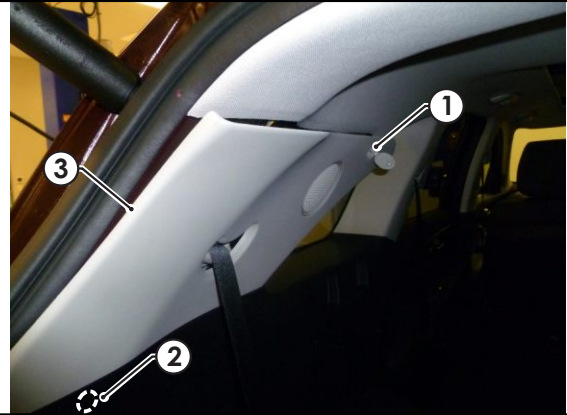

For MY15 models and onwards, go to Step 17. Otherwise, Steps 7 to 16 for Sorento MY12 models only:

7. Remove the LHS tail light (1) by first removing the two screws (2) and disconnect the tail light assembly connectors.

Repeat for the RHS.

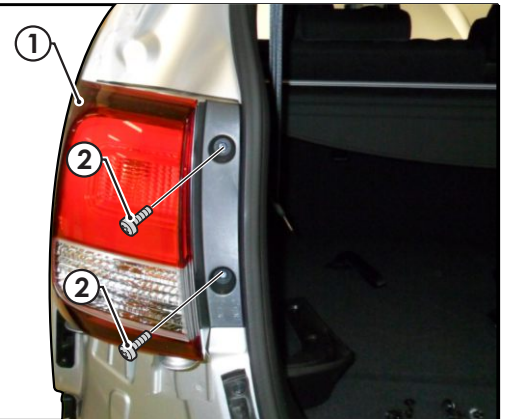

8. Inside the luggage compartment, pull the LHS tail light harness connector (1) and grommet inside the vehicle through the grommet hole (2). Connect the trailer patch (100873-WL) connector (3) to the tail light harness connector (1).

9. Feed the trailer patch connector & grommet out through the grommet hole (2).

Note: Ensure when connecting the trailer patch the grommet makes a good seal.

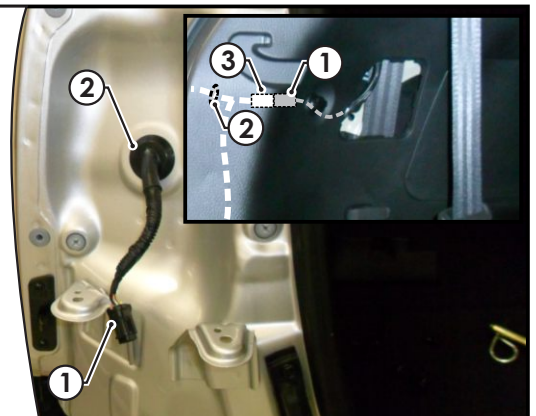

Issue Date 13-08-15

Page 3

Part No: 100873-WL

Hayman Reese (Cequent)
PO Box 4050, Dandenong South VIC 3164
Phone 1800 812 017 Email info@haymanreese.com.au

www.haymanreese.com.au



HAYMAN REESE
PART No: 100873-WL
KIA SORENTO MY12 ONWARDS

INSTALLATION INSTRUCTIONS

PLEASE ENSURE THAT INSTRUCTIONS ARE UNDERSTOOD PRIOR TO FITMENT

10. On the LHS of the luggage compartment, following the table below, connect the ezy-tap (1) to the vehicle 'BLUE' reverse wire (2), then connect the trailer patch terminal (3) to the ezy-tap (1).

Function	Trailer Patch	Vehicle Wire
REVERSE	BLACK / WHITE	BLUE

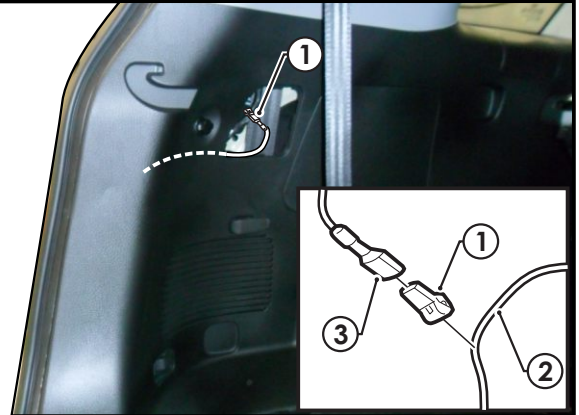

11. Using a tek screw, secure the ground ring terminal (1) to the underside of the LHS bracket (2) as shown.

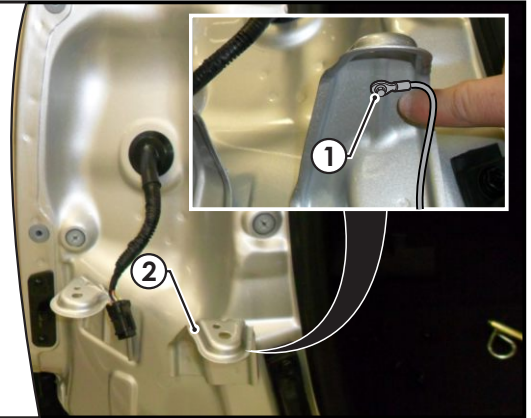

12. Connect the trailer patch 24-way connector (1) to the ECU (04835) (2).

13. Using an alcohol wipe (not supplied), clean the sheet metal area (3) above the LHS bumper spacer bracket as shown where the ECU (2) will be mounted (3) and allow to dry. Apply double sided tape to the ECU (2) and adhere it to the cleaned area on the vehicle sheet metal (3).

Note: Ensure the ECU connector orientation is facing downwards.

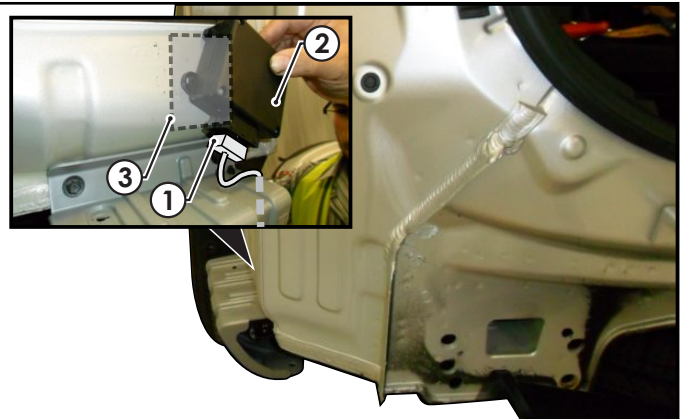

Issue Date 13-08-15

Page 4

Part No: 100873-WL

Hayman Reese (Cequent)
 PO Box 4050, Dandenong South VIC 3164
 Phone 1800 812 017 Email info@haymanreese.com.au

www.haymanreese.com.au



HAYMAN REESE
PART No: 100873-WL
KIA SORENTO MY12 ONWARDS

INSTALLATION INSTRUCTIONS

PLEASE ENSURE THAT INSTRUCTIONS ARE UNDERSTOOD PRIOR TO FITMENT

14. Route the trailer harness (1) along the rear towbar towards the RHS.

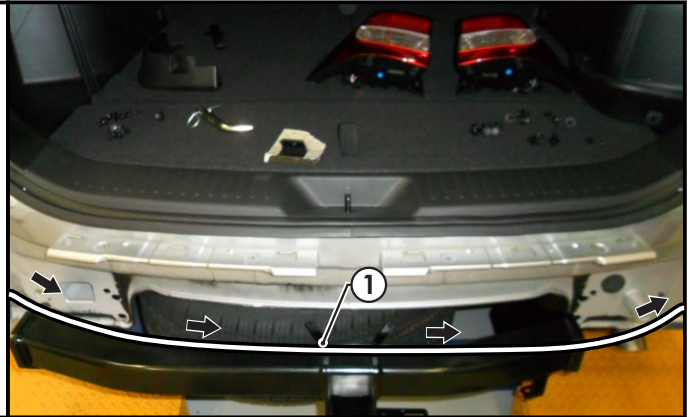

15. Patch the trailer patch connector (1) to the mating vehicle harness tail light connector (2).

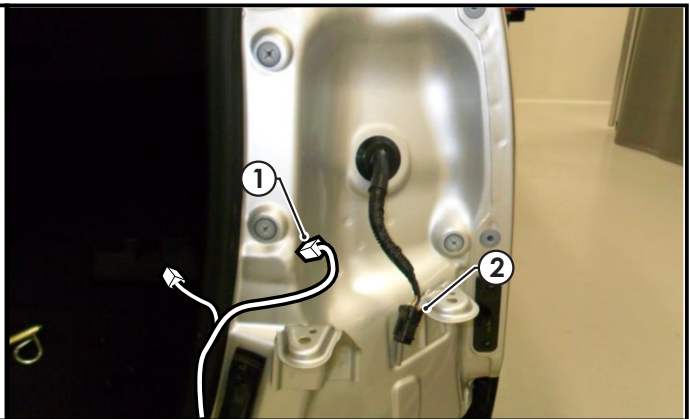

16. On the LHS, connect the 'ORANGE' power wire 1-way connector (1) to its mating 1-way connector (2). **Go to Step 25.**

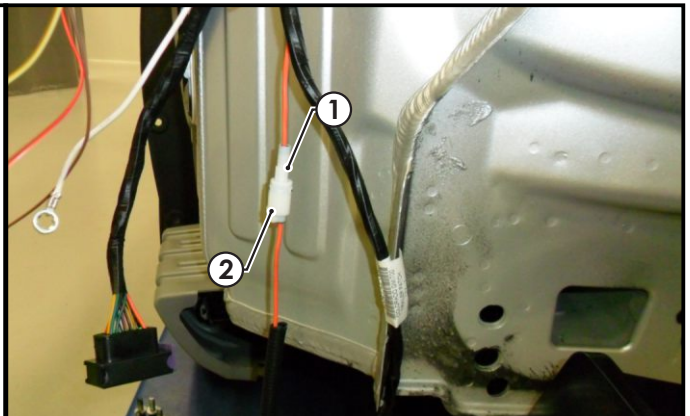

Issue Date 13-08-15

Page 5

Part No: 100873-WL

Hayman Reese (Cequent)
PO Box 4050, Dandenong South VIC 3164
Phone 1800 812 017 Email info@haymanreese.com.au

HAYMAN REESE
PART No: 100873-WL
KIA SORENTO MY12 ONWARDS

INSTALLATION INSTRUCTIONS

PLEASE ENSURE THAT INSTRUCTIONS ARE UNDERSTOOD PRIOR TO FITMENT

Steps 17 to 25 for Sorento MY15 onwards only.

17. Connect the trailer patch (P/No: 100873-WL) LHS connector (1) to the mating vehicle tail light connector (2). Remove the grommet (3) from the trailer patch.

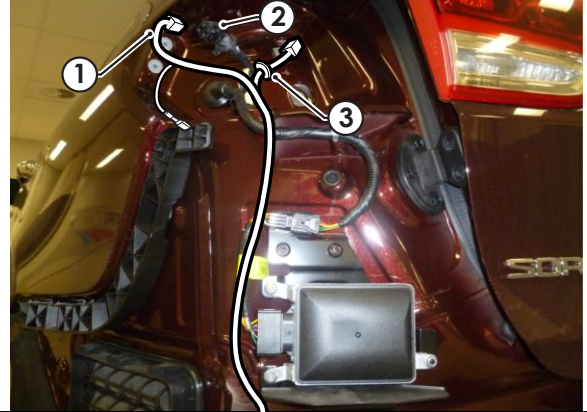

18. Pierce a hole into the vehicle grommet (1) large enough to route the trailer patch reverse wire terminal (2) through.

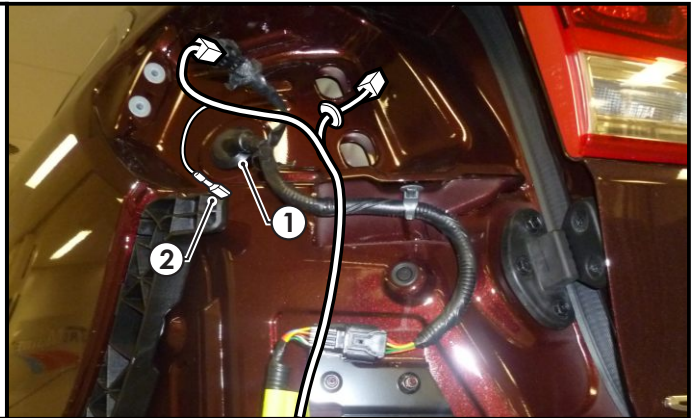

19. On the LHS of the luggage compartment 'D' pillar area, following the table below, connect the ezy-tap (1) to the vehicle 'RED / BLACK' reverse wire (2), then connect the trailer patch terminal (3) to the ezy-tap (1).

Function	Trailer Patch	Vehicle Wire
REVERSE	BLACK / WHITE	RED / BLACK

Seal the grommet with silicone after routing.

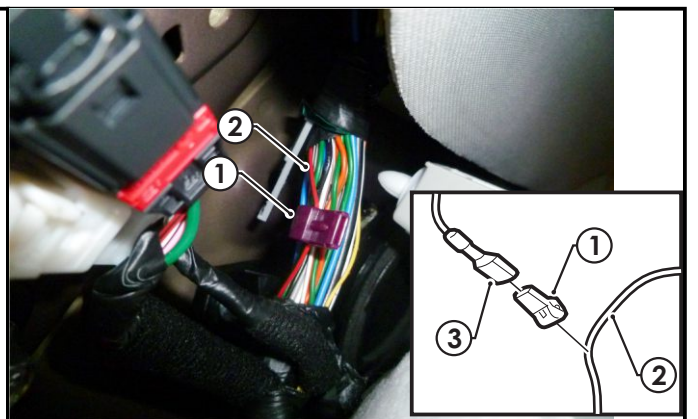

Issue Date 13-08-15

Page 6

Part No: 100873-WL

Hayman Reese (Cequent)
 PO Box 4050, Dandenong South VIC 3164
 Phone 1800 812 017 Email info@haymanreese.com.au



HAYMAN REESE
PART No: 100873-WL
KIA SORENTO MY12 ONWARDS

INSTALLATION INSTRUCTIONS

PLEASE ENSURE THAT INSTRUCTIONS ARE UNDERSTOOD PRIOR TO FITMENT

20. Secure the trailer patch harness ground ring terminal (1) to the BSM module bracket fastener point (2).

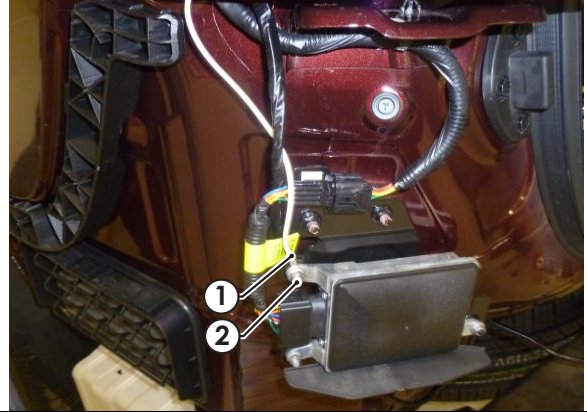

21. Connect the trailer patch 24-way connector (1) to the ECU (04835) (2).
22. Using an alcohol wipe (not supplied), clean the area on the vehicle sheet metal underneath the LHS BSM module where the ECU will be mounted. Apply double sided tape to the ECU (2) and adhere it to the vehicle sheet metal.

Note: Ensure the ECU connector orientation is facing downwards.

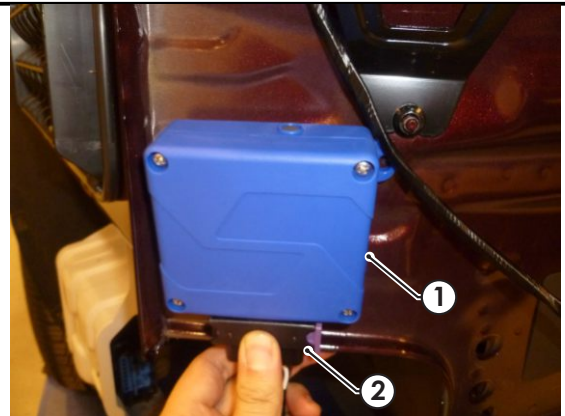

23. Route the trailer patch across to the RHS of the vehicle and connect the trailer patch RHS connector (1) to the mating vehicle harness tail light connector. **The routing of the trailer patch harness must be routed in a way that does not interfere with the functioning of the BSM.**



Issue Date 13-08-15

Page 7

Part No: 100873-WL

Hayman Reese (Cequent)
PO Box 4050, Dandenong South VIC 3164
Phone 1800 812 017 Email info@haymanreese.com.au

www.haymanreese.com.au



HAYMAN REESE
PART No: 100873-WL
KIA SORENTO MY12 ONWARDS

INSTALLATION INSTRUCTIONS

PLEASE ENSURE THAT INSTRUCTIONS ARE UNDERSTOOD PRIOR TO FITMENT

24. On the LHS, connect the 'ORANGE' power wire 1-way connector (1) to its mating 1-way connector (2).
25. Route the 'ORANGE' power wire (1) around to the LHS of the vehicle and along the LHS vehicle chassis rail towards the front of the vehicle and up towards the engine bay. **Keep harness routing clear of any sharp edges or moving parts.**

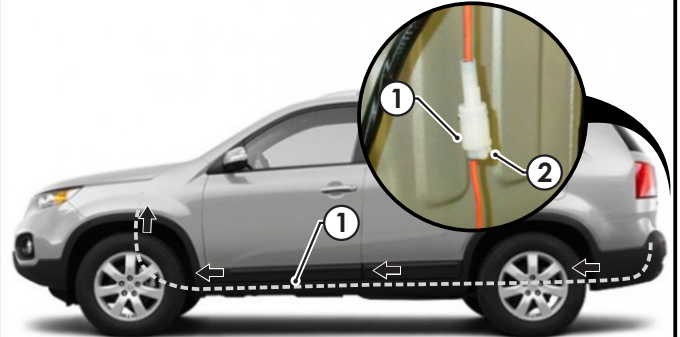

26. In the engine bay, secure the 'ORANGE' power wire ring terminal (1) to the vehicle's positive battery terminal (2).



27. Mount the trailer socket (1) to the tow bar mounting bracket using M4 fasteners (not supplied).
28. Route the tail harness (2) across the tow bar towards the LHS of the vehicle.

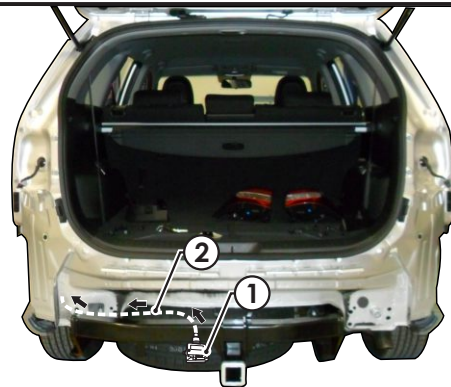

Issue Date 13-08-15

Page 8

Part No: 100873-WL

Hayman Reese (Cequent)
PO Box 4050, Dandenong South VIC 3164
Phone 1800 812 017 Email info@haymanreese.com.au

www.haymanreese.com.au



HAYMAN REESE
PART No: 100873-WL
KIA SORENTO MY12 ONWARDS

INSTALLATION INSTRUCTIONS

PLEASE ENSURE THAT INSTRUCTIONS ARE UNDERSTOOD PRIOR TO FITMENT

29. Connect the tail harness (tail length 400mm) 8-way connector (1) to the trailer patch mating 8-way connector (2).
30. Waterproof the connectors by applying electrical grease or silicone (3) to the back of each connector.

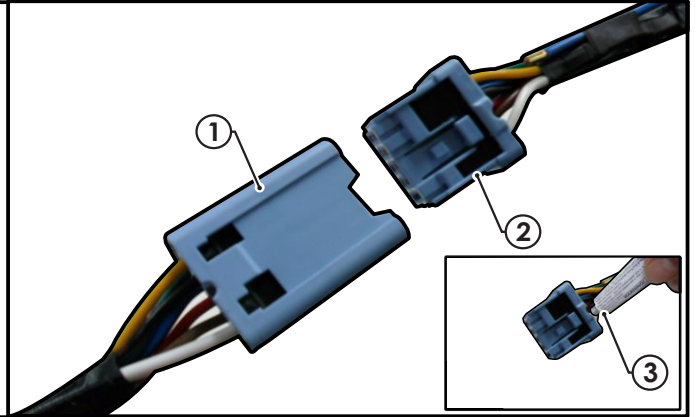

31. Test the trailer patch function using a light board or multi-meter.
32. Secure all harnesses using cable ties (not supplied).
33. Re-fit all removed parts and secure all fasteners, ensuring there are no squeaks or rattles.
34. Place the fitting instructions in the glove box after fitment.

Issue Date 13-08-15

Page 9

Part No: 100873-WL

Hayman Reese (Cequent)
PO Box 4050, Dandenong South VIC 3164
Phone 1800 812 017 Email info@haymanreese.com.au

www.haymanreese.com.au





FITTING INSTRUCTIONS

Smart Pin (55070BL)

• These fitting instructions are supplied to ensure understanding of how the SMART PIN should be fitted and used correctly.

• Once installed, we recommend **ALL** instructions are kept and placed in the vehicle glove box.

NOTE: Routine maintenance and inspection of the towbar & SMART PIN is required. Regularly inspect for wear and check the tightness of the SMART PIN NUT. Follow instructions below to retighten the nut when necessary.

***Do not tow with your vehicle if the R CLIP or the SMART PIN NUT is loose or missing. Replacement parts are available from your Hayman Reese Distributor.**

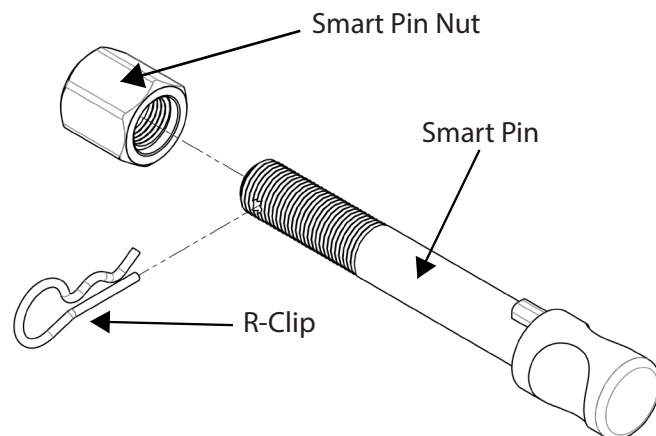
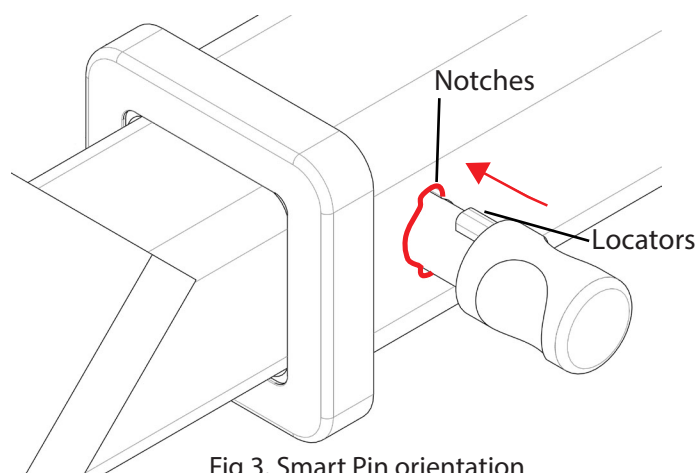
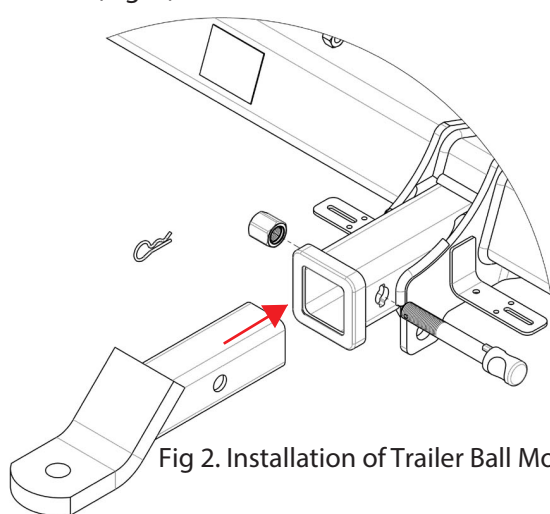

Fig 1. Smart Pin assembly

STEP 1 Insert Trailer Ball Mount (TBM) into towbar HITCHBOX, aligning hole in TBM SHANK with hole in HITCHBOX (Fig. 2).



STEP 2 Insert SMART PIN through hole in HITCHBOX and hole in TBM SHANK; ensure the LOCATORS are inserted into the NOTCHES in the HITCHBOX (Fig. 3).

STEP 3 Screw SMART PIN NUT onto SMART PIN; tighten SMART PIN NUT until finger tight, ensuring TBM is restrained from movement.

STEP 4 Tighten SMART PIN NUT by turning nut a further 1/8th of a turn in the clockwise direction using a 24mm spanner (Fig 4).

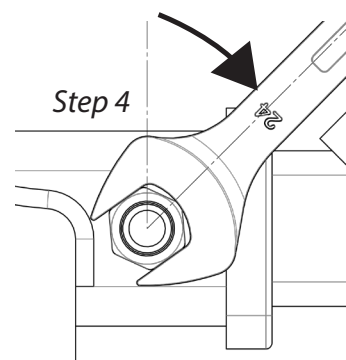

STEP 5 Install SMART PIN R CLIP through the hole on the SMART PIN (Fig. 1).

