

HAYMAN REESE
PART No: 03090RW
AUDI A3 SPORTBACK 8V – 05/2013 ONWARD

INSTALLATION INSTRUCTIONS

PLEASE ENSURE THAT ALL INSTRUCTIONS ARE UNDERSTOOD PRIOR TO FITMENT
PLACE THESE INSTRUCTIONS IN THE VEHICLE'S GLOVEBOX AFTER INSTALLATION IS COMPLETED



Installation Time: Approx 60 Mins

Towbar Installation Instructions

Towbar capacity

AUDI A3 SPORTBACK 8V – 05/2013 ONWARD

Part Number 03090RW

Max Towing Braked 1800 kg

Max Towing Unbraked 730 kg

Max Static Ball Load 75 kg

Hayman Reese (Cequent)
PO Box 4050, Dandenong South VIC 3164
Phone 1800 812 017 Email info@haymanreese.com.au

HAYMAN REESE
PART No: 03090RW
AUDI A3 SPORTBACK 8V – 05/2013 ONWARD

INSTALLATION INSTRUCTIONS

PLEASE ENSURE THAT ALL INSTRUCTIONS ARE UNDERSTOOD PRIOR TO FITMENT
PLACE THESE INSTRUCTIONS IN THE VEHICLE'S GLOVEBOX AFTER INSTALLATION IS COMPLETED

Warning:

1. Do not, drill, cut, weld or otherwise modify the towbar.
2. If you are using electric welding on a motor vehicle, **always** check that the vehicle is not equipped with electronic engine or instrument management equipment. Failure to do so could **destroy** any onboard computers. If in doubt, check with the vehicle's manufacturer.
3. If TBM is used in inverted position tow ball may make contact with rear tailgate when lowered, which could cause damage.

General:

1. Ensure all hardware items have been included refer to assembly diagram.
2. It is recommended that the instructions are read through and completely understood before making any attempt to fit this product.
3. Be wary of any changes to vehicle designs or other accessories that may conflict with the installation of this product.
4. Before drilling ensure that the area is clear of fuel, electrical & other components.
5. All holes drilled into the body panels shall have all burrs & swarf removed then coated with a suitable rust preventative paint.
6. The high tensile fasteners supplied with this product were used to achieve the specified rating. If replacement is required ensure that fasteners of the same rating & quality are used. Contact an authorised **Hayman Reese** dealer if further information is required.
7. Ensure that all hardware is fastened to torque list below check fasteners on regular basis.
8. Towbar load rating sticker provided with this product shall be conspicuously located on inside rear end of the driver's door. **(See diagram below).**
9. Hayman Reese recommends that you check your tow ball to ensure that it complies with the Australian standards **AS 4177.2**.
10. **PLEASE NOTE:** It is advised to remove your LUG or TBM when not actually towing so as to produce a clear view of the vehicles registration plate if obscured, and to also provide maximum available departure angle.
11. Pull Pin must be fit in down position.

Tow bar Maintenance and Care.

Hayman Reese recommends that bolt torque's, as listed below, are routinely and regularly inspected and checked for correct tension. Replace any worn or defective parts.

We recommended to remove Tow Ball Mounts (TBM's, tongues or lugs) when not being used for any considerable length of time.

So as to avoid injury, when not towing it is suggested that the tongue, Pull Pin and R-clip are removed then stored in a safe, clean and dry place, away from excessive moisture.

Hitch Pull Pins and spring "R" clips are regularly checked for proper installation. Replace any worn or defective parts.

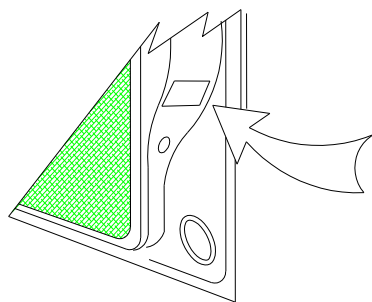

Place load rating sticker
inside driver's door here

RECOMMENDED ASSEMBLY TORQUE LISTING

Diameter Grade 8.8 Bolt

M6	9.5 Nm
M8	21.7 Nm
M10	43.4 Nm
M12	77.3 Nm
M14	146 Nm
M16	189.8 Nm

FOR TOWING PURPOSES ONLY

For towing capacity details please refer to vehicle owner's manual or to the manufacturer. Overloading can void your warranties.

HAYMAN REESE

PART No: 03090RW

AUDI A3 SPORTBACK 8V – 05/2013 ONWARD

INSTALLATION INSTRUCTIONS

PLEASE ENSURE THAT ALL INSTRUCTIONS ARE UNDERSTOOD PRIOR TO FITMENT
PLACE THESE INSTRUCTIONS IN THE VEHICLE'S GLOVEBOX AFTER INSTALLATION IS COMPLETED

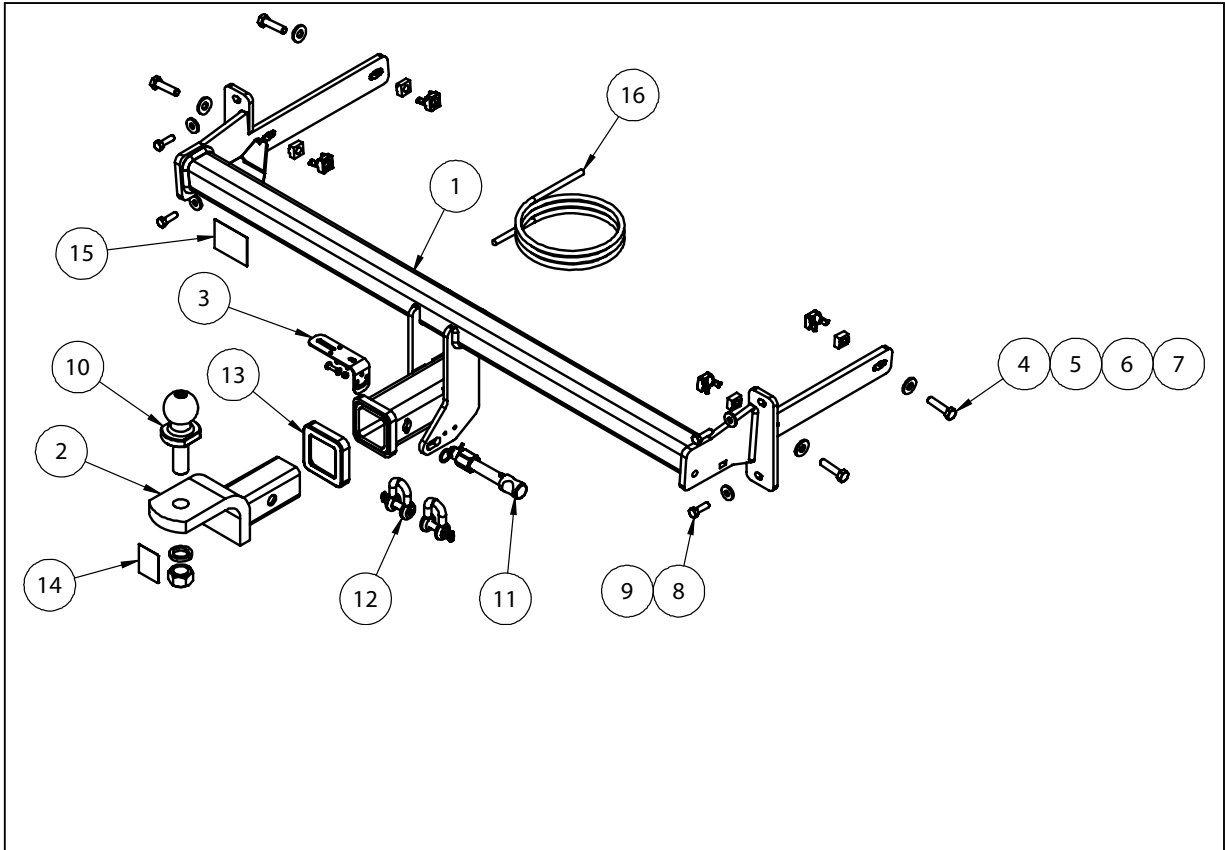

QTY.	DESCRIPTION	ITEM NO.
1	WELDED ASSY	1
1	TBM ASSY	2
1	UNIVERSAL PLUG BRACKET KIT	3
4	BOLT M12-1.5x40mm	4
4	WASHER FLAT M10x25.4x3	5
4	CAGE NUT M10X1.5	6
4	CAGE NUT RETAINER	7
4	SET SCREW M8x25	8
4	FLAT WASHER M8x22x3.3mm	9
1	HR TOWBALL	10
1	ANTI RATTLE PILL PIN ASSY GOLD	11
2	10mm "D" SHACKLE	12
1	HITCH BOX COLLAR COVER	13
1	HR STICKER	14
1	ACRYLIC CP	15
1	WIRING LOOM	16

HAYMAN REESE
PART No: 03090RW
AUDI A3 SPORTBACK 8V – 05/2013 ONWARD

INSTALLATION INSTRUCTIONS

PLEASE ENSURE THAT ALL INSTRUCTIONS ARE UNDERSTOOD PRIOR TO FITMENT
PLACE THESE INSTRUCTIONS IN THE VEHICLES'S GLOVEBOX AFTER INSTALLATION IS COMPLETED

1. Remove 3x Screws from within rear wheel arch. Repeat for opposite side of the vehicle.

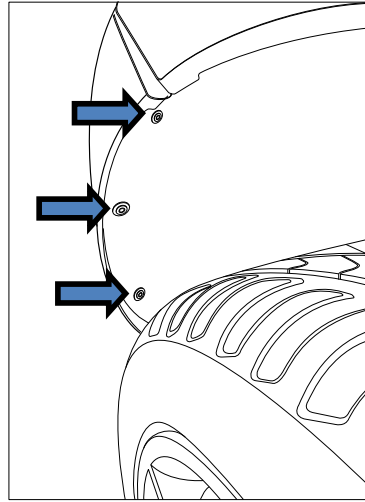

2. Remove 1x Screw from within rear wheel arch, securing bumper to body work. Repeat for opposite side of the vehicle.

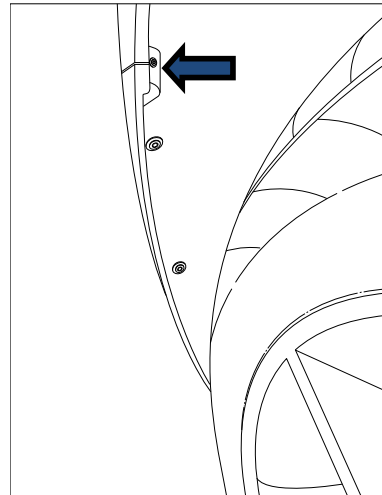

3. Remove 2x Screws from underside of rear bumper.

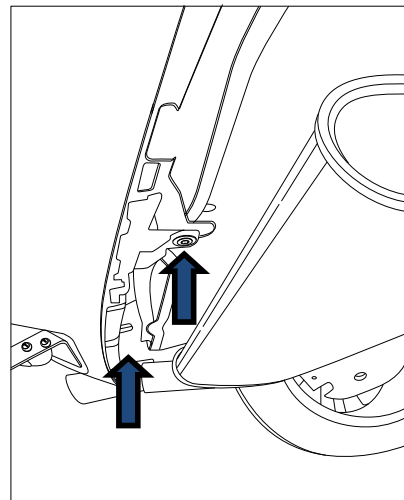

HAYMAN REESE
PART No: 03090RW
AUDI A3 SPORTBACK 8V – 05/2013 ONWARD

INSTALLATION INSTRUCTIONS

PLEASE ENSURE THAT ALL INSTRUCTIONS ARE UNDERSTOOD PRIOR TO FITMENT
PLACE THESE INSTRUCTIONS IN THE VEHICLE'S GLOVEBOX AFTER INSTALLATION IS COMPLETED

4. Remove boot floor.

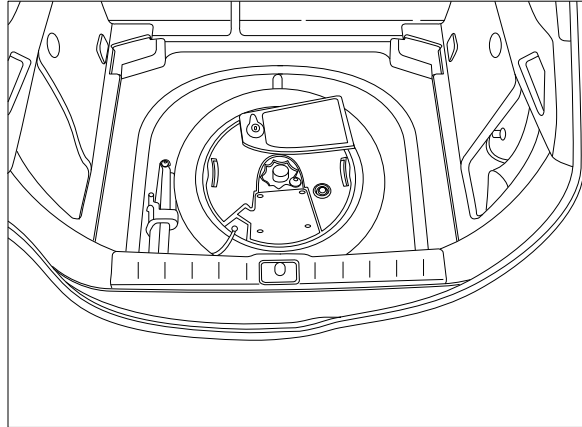

5. Unclip and remove rear boot interior trim.

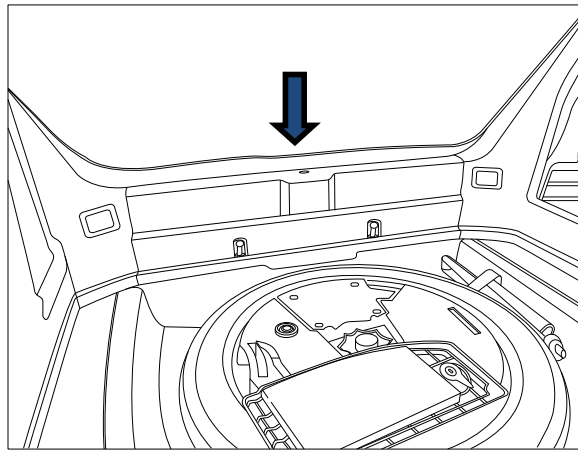

6. Remove boot interior side panel. Remove Nut securing tail light assembly. Repeat for opposite side of the vehicle.

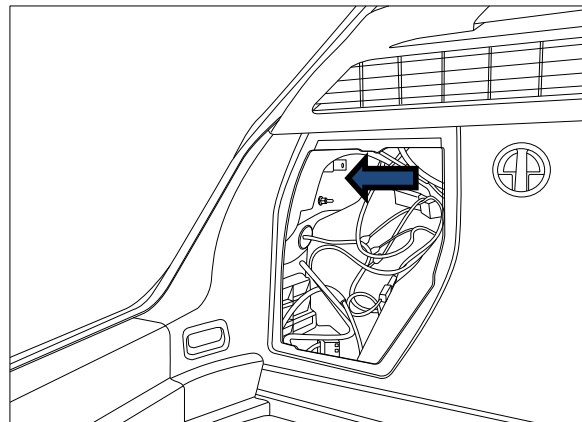

HAYMAN REESE

PART No: 03090RW

AUDI A3 SPORTBACK 8V – 05/2013 ONWARD

INSTALLATION INSTRUCTIONS

PLEASE ENSURE THAT ALL INSTRUCTIONS ARE UNDERSTOOD PRIOR TO FITMENT
PLACE THESE INSTRUCTIONS IN THE VEHICLE'S GLOVEBOX AFTER INSTALLATION IS COMPLETED

7. Remove and disconnect tail light assembly.
Repeat for opposite side of the vehicle.

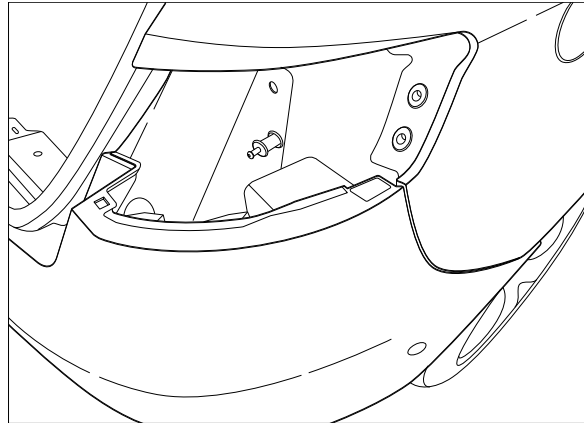

8. Remove 4x Nuts from inside boot, securing rear bumper to chassis.

Note that a long socket may be required to access nuts over locating studs.

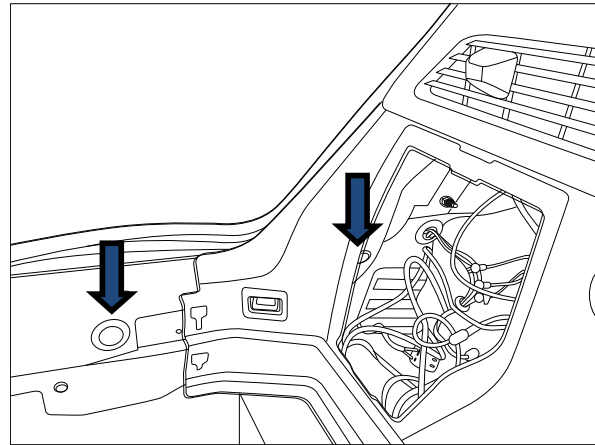

9. Remove plastic locking Pin at outer edge of bumper, below tail light assembly location.
Repeat for opposite side of the vehicle.

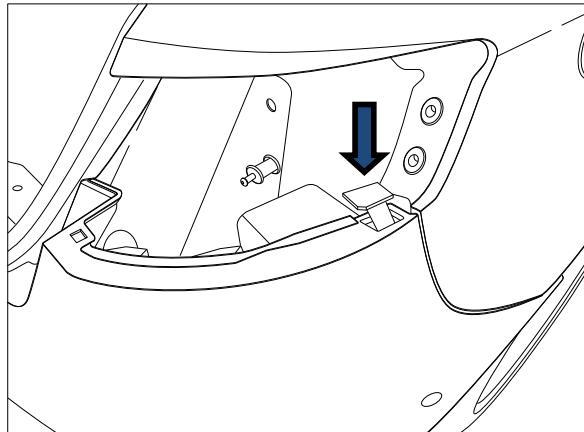

HAYMAN REESE
PART No: 03090RW
AUDI A3 SPORTBACK 8V – 05/2013 ONWARD

INSTALLATION INSTRUCTIONS

PLEASE ENSURE THAT ALL INSTRUCTIONS ARE UNDERSTOOD PRIOR TO FITMENT
PLACE THESE INSTRUCTIONS IN THE VEHICLES'S GLOVEBOX AFTER INSTALLATION IS COMPLETED

- 10.** Carefully unclip and remove rear bumper; store in a safe location. Disconnect rear parking sensor loom as bumper is removed.

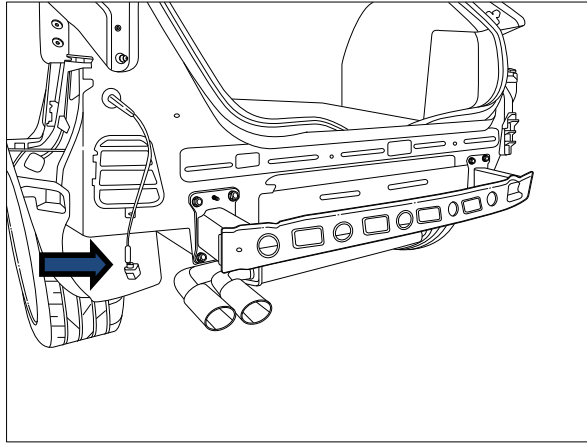

- 11.** Remove and discard 8x Set Screws (4x Set Screws per side) securing impact beam to rear panel of vehicle. Remove and discard impact beam.

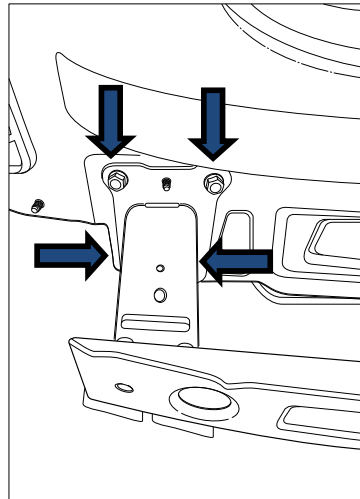

- 12.** Offer Towbar to vehicle, sliding sidearms into chassis rails.

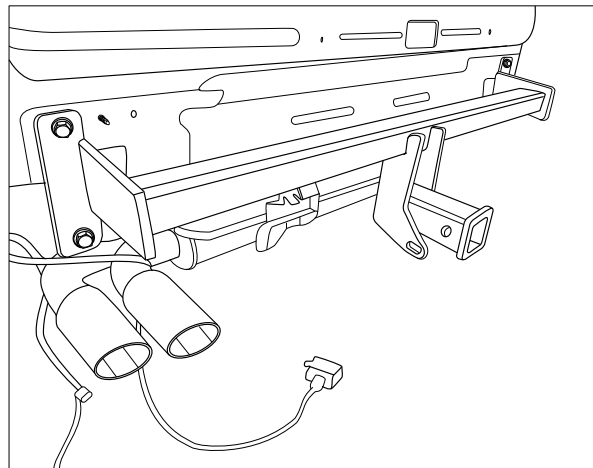

HAYMAN REESE
PART No: 03090RW
AUDI A3 SPORTBACK 8V – 05/2013 ONWARD

INSTALLATION INSTRUCTIONS

PLEASE ENSURE THAT ALL INSTRUCTIONS ARE UNDERSTOOD PRIOR TO FITMENT
PLACE THESE INSTRUCTIONS IN THE VEHICLES'S GLOVEBOX AFTER INSTALLATION IS COMPLETED

- 13. Loosely secure sidearms to chassis rails using 2x M10 Bolts per sidearm, complete with 1x M10 Flat Washer per Bolt.
- 14. Loosely secure rear panel mount of Towbar to rear panel of vehicle using 2x M8 Set Screws per side, complete with 1x M8 Flat Washer per Set Screw.
- 15. Tighten the 4x M10 Bolts and 4x M8 Set Screws to torques specified on page 2 of this document.

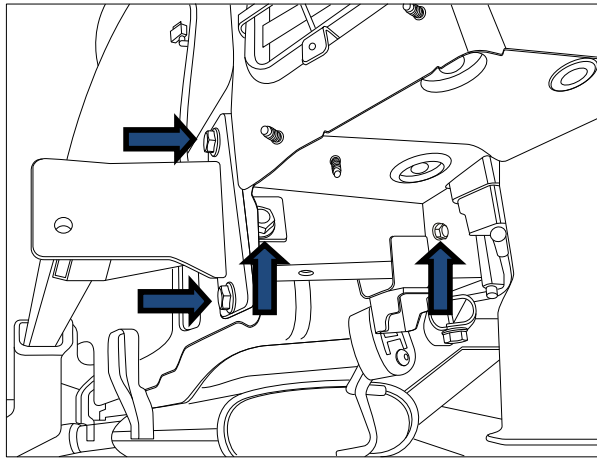

- 16. Secure plug bracket to LHS of Hitch receiver using fasteners provided.

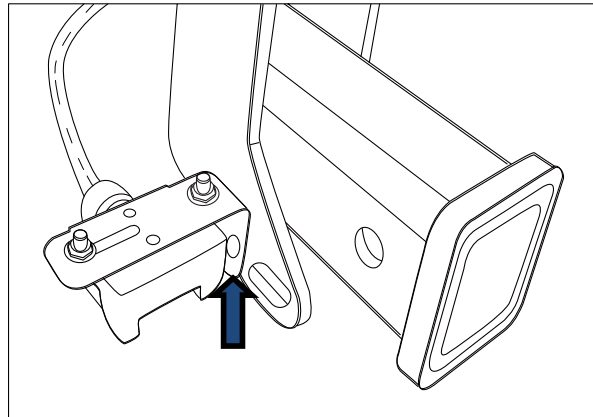

- 17. Separate lower section of rear bumper from main bumper fascia.

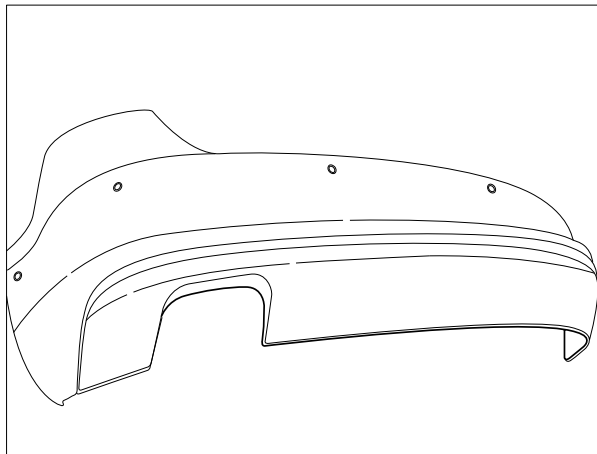

INSTALLATION INSTRUCTIONS

PLEASE ENSURE THAT ALL INSTRUCTIONS ARE UNDERSTOOD PRIOR TO FITMENT
PLACE THESE INSTRUCTIONS IN THE VEHICLES'S GLOVEBOX AFTER INSTALLATION IS COMPLETED

18. Create bumper cut in bumper lower section as per dimensions shown. Add Pinch Weld provided to edge of bumper cut.

19. Reinstall bumper following steps 1 to 10 & 17 in reverse order.

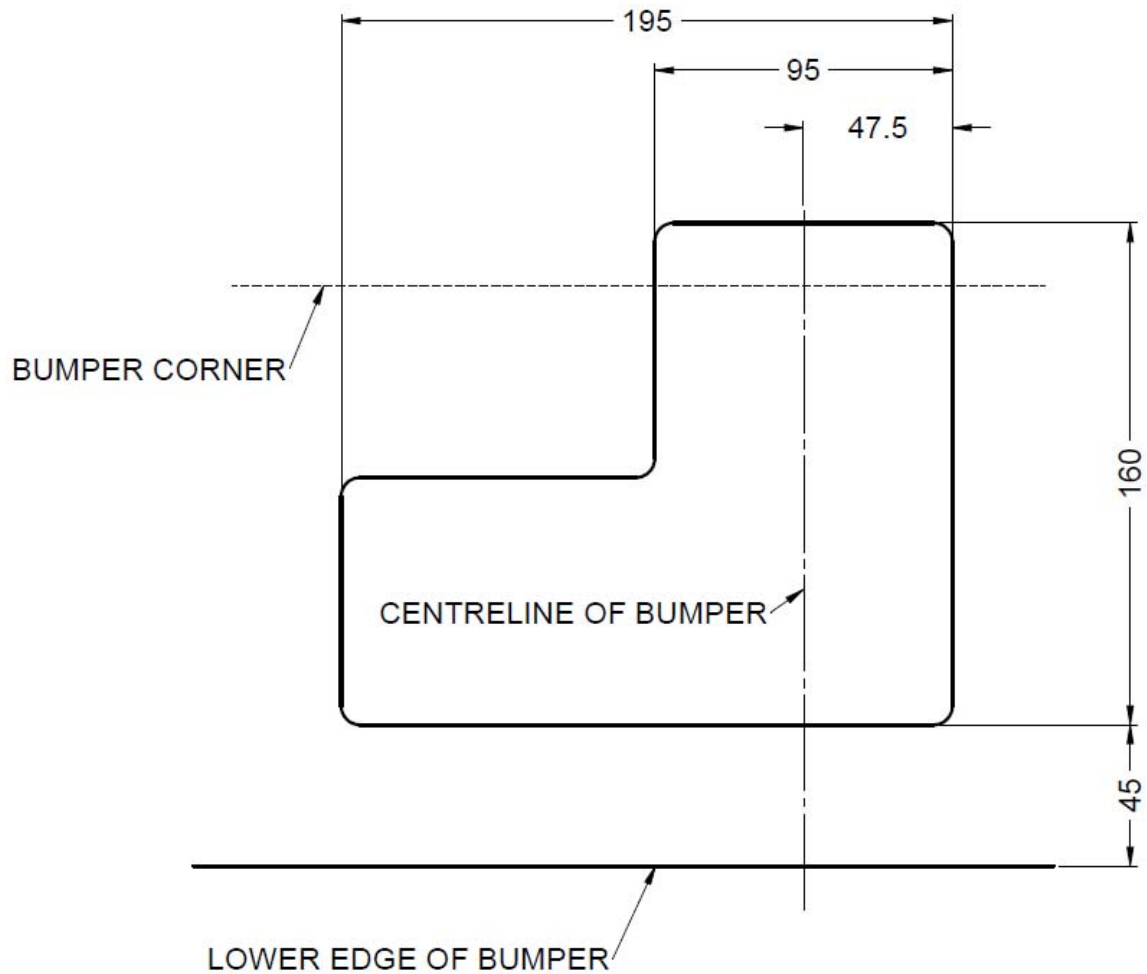
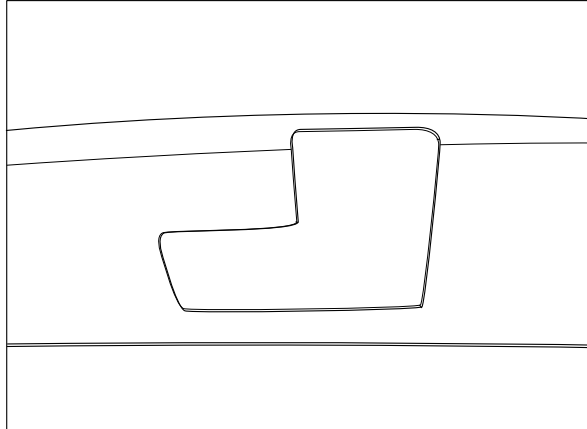

HAYMAN REESE
PART No: 101238-WL
AUDI A3 MY15

INSTALLATION INSTRUCTIONS

PLEASE ENSURE THAT INSTRUCTIONS ARE UNDERSTOOD PRIOR TO FITMENT

Wiring Loom Installation Instructions

AUDI A3 MY15

Part No: 101238-WL

ECU Required: 04826

Power Harness Required: 04825

Tail Harness Length Required: 1200mm

Wiring Loom Installation Time: Approx. 50 minutes

Important



Due to possible vehicle variations, always confirm any noted vehicle colour wires with a multi-meter to ensure the correct function is identified before soldering or scotch locking.

Issue Date 10-04-15

Page 1

Part No: 101238-WL

Hayman Reese (Cequent)
PO Box 4050, Dandenong South VIC 3164
Phone 1800 812 017 Email info@haymanreese.com.au

www.haymanreese.com.au



HAYMAN REESE
PART No: 101238-WL
AUDI A3 MY15

INSTALLATION INSTRUCTIONS

PLEASE ENSURE THAT INSTRUCTIONS ARE UNDERSTOOD PRIOR TO FITMENT

1. At the rear of the vehicle, remove the parcel shelf (1).
2. Remove the cargo net (if fitted) (2).
3. Remove the floor carpet cover (3) and fold down the rear seats (4).
4. Remove the luggage compartment rear trim (5).

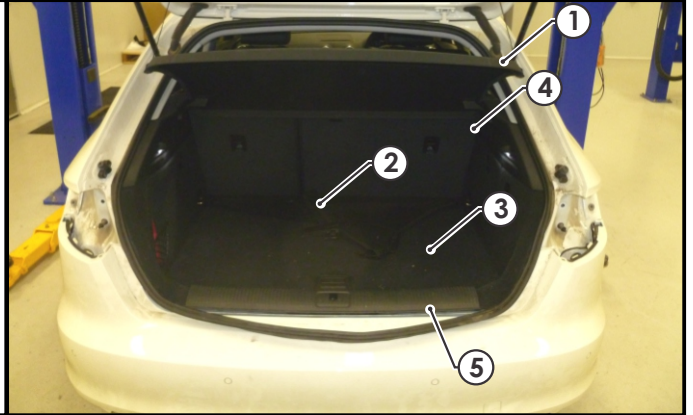

5. Dislodge the luggage compartment LHS access panel (1). Disconnect the 12v connector (2) from the LHS access panel and then remove the access panel (1).
6. Remove the trim fasteners (4).
7. Remove the luggage compartment trim (6).

Repeat applicable steps for the RHS luggage trim.

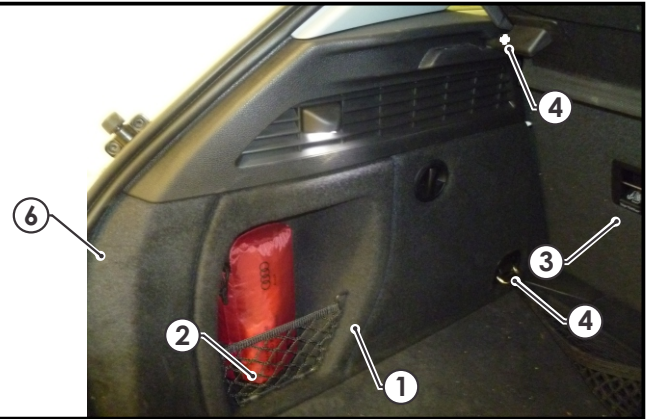

8. At the LHS exterior rear quarter underside of the vehicle, remove the vehicle grommet (1) and drill the grommet hole out to Ø30mm. **Ensure the interior area is clear of obstructions before drilling.**

Note: If the vehicle grommet is occupied, drill into the sheet metal next to the grommet (2).

Apply rust inhibitor after drilling.

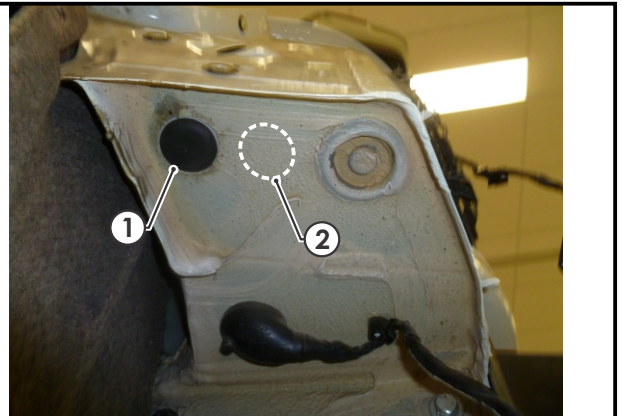

Issue Date 10-04-15

Page 2

Part No: 101238-WL

Hayman Reese (Cequent)
PO Box 4050, Dandenong South VIC 3164
Phone 1800 812 017 Email info@haymanreese.com.au

www.haymanreese.com.au



HAYMAN REESE
PART No: 101238-WL
AUDI A3 MY15

INSTALLATION INSTRUCTIONS

PLEASE ENSURE THAT INSTRUCTIONS ARE UNDERSTOOD PRIOR TO FITMENT

9. In the engine bay, route the power harness (P/No: 04825) (1) from the battery area. Drop the harness down to the bottom where the LHS chassis is. **Do not connect harness terminal to power at this point.**

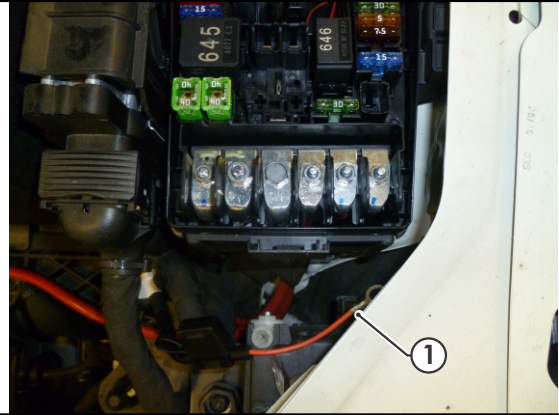

10. Continue routing the power harness (1) along the LHS chassis (above the shroud), towards the rear of the vehicle.

Note: When routing any harnesses underneath the vehicle, ensure to avoid all moving parts, sources of heat and sharp objects.



11. Pierce a hole or make an incision into the vehicle grommet (1) and route the power harness (2) through into the vehicle. Seal the cut hole with silicone after routing into place. Ensure there is enough slack for the harness 1-way connector to reach the trailer patch connection point (refer to Step 17).

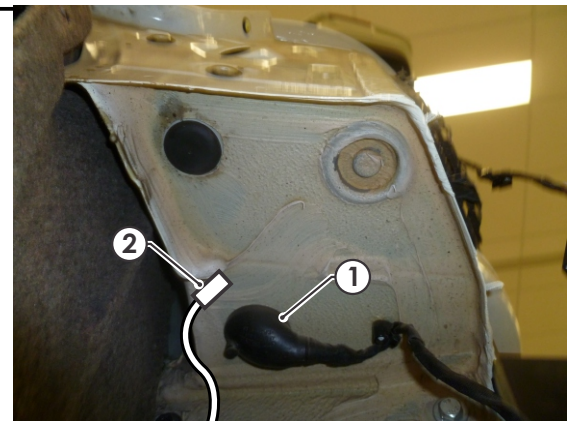

Issue Date 10-04-15

Page 3

Part No: 101238-WL

Hayman Reese (Cequent)
PO Box 4050, Dandenong South VIC 3164
Phone 1800 812 017 Email info@haymanreese.com.au

HAYMAN REESE
PART No: 101238-WL
AUDI A3 MY15

INSTALLATION INSTRUCTIONS

PLEASE ENSURE THAT INSTRUCTIONS ARE UNDERSTOOD PRIOR TO FITMENT

12. Route the trailer patch (P/No: 101238-WL) terminals (1) to the LHS tail light harness wires (2).
13. Following the table, connect the trailer patch ezy taps (3) to the vehicle harness wires (2) and then connect the trailer patch terminals (1) to the corresponding wires (2).

Function	Trailer Patch	Vehicle Connector
L.IND	GREEN / BLACK	BLUE / YELLOW
TAILS	BROWN / BLACK	BLUE / WHITE
BRAKES	RED / BLACK	BLUE
REVERSE	BLACK / WHITE	GREEN/ RED

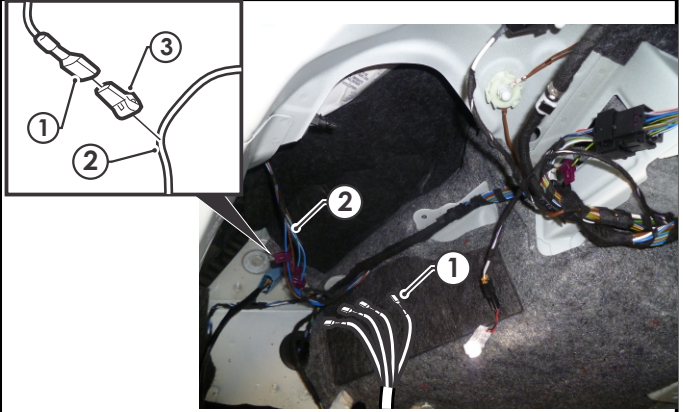

14. In the LHS interior rear quarter area beside the wheel arch, clean the inner sheet metal outer side with an alcohol wipe (not supplied).
15. Connect the 12-way trailer patch connector (1) to the ECU (2) and adhere the ECU (2) to the cleaned area on the sheet metal. **Ensure the ECU is mounted with the connector pointing downwards.**
16. Secure the trailer patch WHITE wire ground terminal (3) to the vehicle grounding point (4) using the existing fastener.

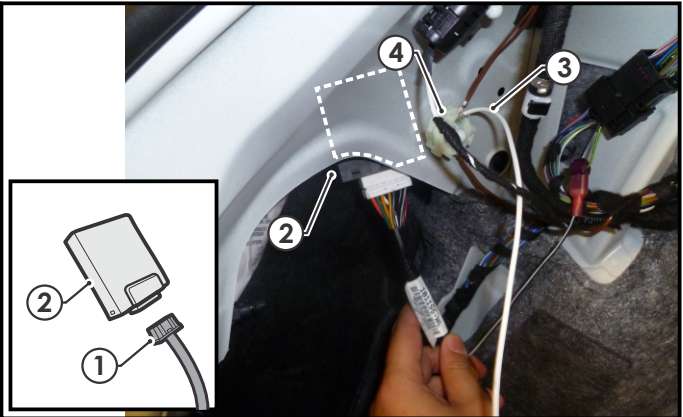

17. Connect the 1-way power wire connector (2) to the trailer harness 1-way mating connector (1).
18. Route the trailer patch RH branch across the rear of the vehicle and towards the vehicle RHS tail light harness.

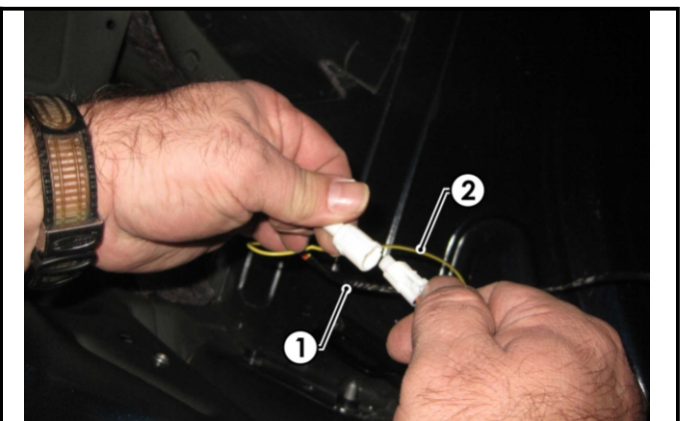

Issue Date 10-04-15

Page 4

Part No: 101238-WL

Hayman Reese (Cequent)
 PO Box 4050, Dandenong South VIC 3164
 Phone 1800 812 017 Email info@haymanreese.com.au

www.haymanreese.com.au



HAYMAN REESE
PART No: 101238-WL
AUDI A3 MY15

INSTALLATION INSTRUCTIONS

PLEASE ENSURE THAT INSTRUCTIONS ARE UNDERSTOOD PRIOR TO FITMENT

19. At the RHS tail light area, following the table, connect the ezy tap (1) to the vehicle harness wire (2) and then connect the trailer harness terminal (3) to the corresponding wire (2).

Function	Trailer Patch	Vehicle Connector
R.IND	GREEN / BLACK	PURPLE / BROWN

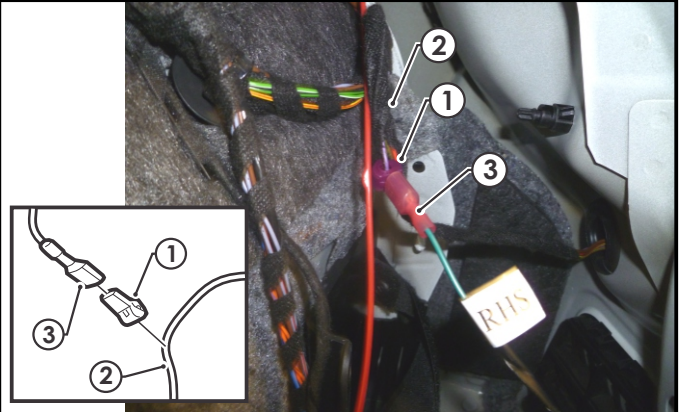

20. At the rear exterior of the vehicle, mount the tail harness socket (1) to the towbar mounting bracket using M4 fasteners (not supplied).

21. Route the tail harness (tail length: 1200mm) (2) across the LHS and up into the drilled out hole (3). Adjust the trailer patch harness grommet so that it is seated correctly and cable tie (not supplied) in place.

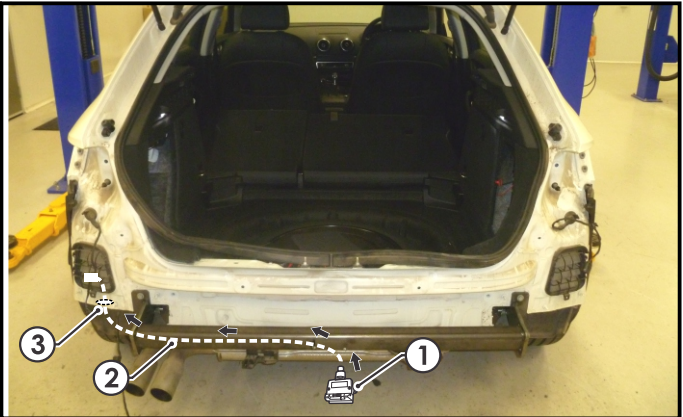

22. In the engine bay, remove the fuse panel cover and connect the power harness orange wire ring terminal (1) to the indicated terminal (2).



Issue Date 10-04-15

Page 5

Part No: 101238-WL

Hayman Reese (Cequent)
 PO Box 4050, Dandenong South VIC 3164
 Phone 1800 812 017 Email info@haymanreese.com.au

www.haymanreese.com.au



HAYMAN REESE
PART No: 101238-WL
AUDI A3 MY15

INSTALLATION INSTRUCTIONS

PLEASE ENSURE THAT INSTRUCTIONS ARE UNDERSTOOD PRIOR TO FITMENT

- | | |
|--|--|
| <p>23. Test the trailer wiring harness function using a light board or multi-meter.</p> <p>24. Secure all harnesses using cable ties (not supplied).</p> <p>25. Re-fit all removed parts and secure all fasteners, ensuring there are no squeaks or rattles.</p> <p>26. Place the fitting instructions in the glove box after fitment.</p> | |
|--|--|

Issue Date 10-04-15

Page 6

Part No: 101238-WL

Hayman Reese (Cequent)
PO Box 4050, Dandenong South VIC 3164
Phone 1800 812 017 Email info@haymanreese.com.au

www.haymanreese.com.au





FITTING INSTRUCTIONS

Smart Pin (55070BL)

• These fitting instructions are supplied to ensure understanding of how the SMART PIN should be fitted and used correctly.

• Once installed, we recommend **ALL** instructions are kept and placed in the vehicle glove box.

NOTE: Routine maintenance and inspection of the towbar & SMART PIN is required. Regularly inspect for wear and check the tightness of the SMART PIN NUT. Follow instructions below to retighten the nut when necessary.

***Do not tow with your vehicle if the R CLIP or the SMART PIN NUT is loose or missing. Replacement parts are available from your Hayman Reese Distributor.**

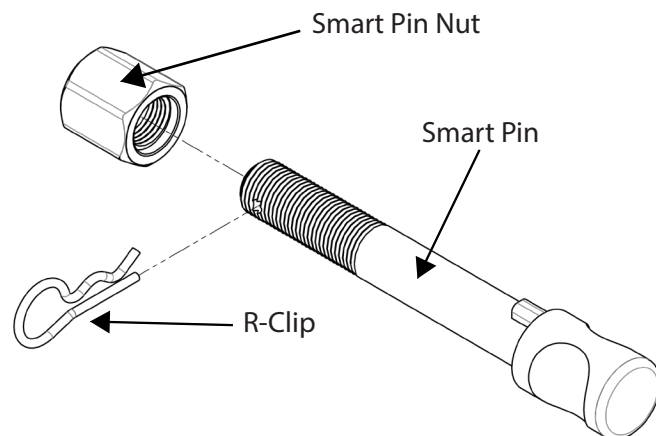
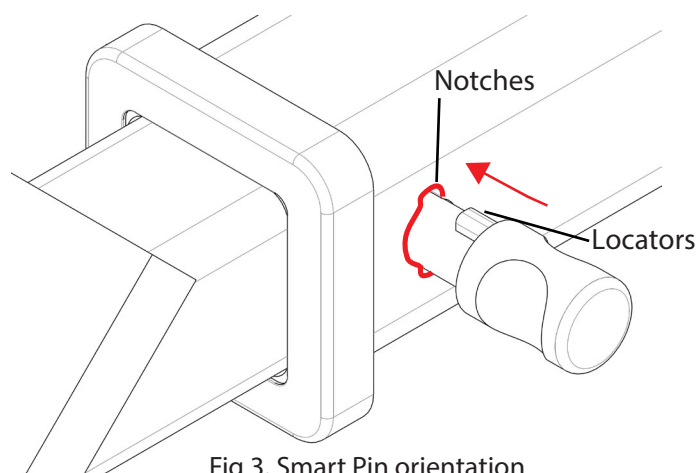
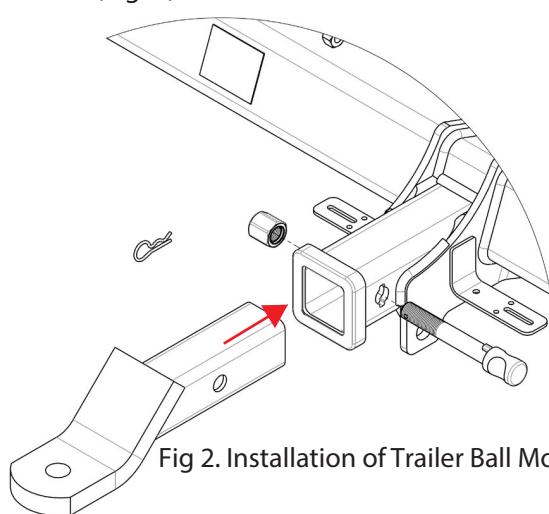

Fig 1. Smart Pin assembly

STEP 1 Insert Trailer Ball Mount (TBM) into towbar HITCHBOX, aligning hole in TBM SHANK with hole in HITCHBOX (Fig. 2).



STEP 2 Insert SMART PIN through hole in HITCHBOX and hole in TBM SHANK; ensure the LOCATORS are inserted into the NOTCHES in the HITCHBOX (Fig. 3).

STEP 3 Screw SMART PIN NUT onto SMART PIN; tighten SMART PIN NUT until finger tight, ensuring TBM is restrained from movement.

STEP 4 Tighten SMART PIN NUT by turning nut a further 1/8th of a turn in the clockwise direction using a 24mm spanner (Fig 4).

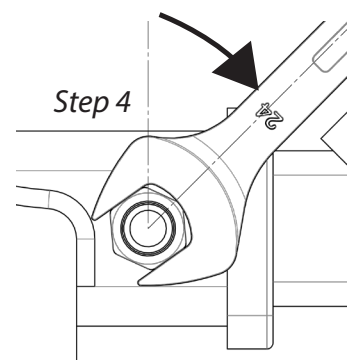

STEP 5 Install SMART PIN R CLIP through the hole on the SMART PIN (Fig. 1).

