

HAYMAN REESE
PART No: 02880RW
HYUNDAI i40 WAGON 2011

INSTALLATION INSTRUCTIONS

PLEASE ENSURE THAT INSTRUCTIONS ARE UNDERSTOOD PRIOR TO FITMENT



Installation Time: Approx 100 Mins

Towbar Installation Instructions
HYUNDAI i40 WAGON

Towbar capacity

Part Number 02880RW

Max Towing Braked 1500kg

Max Static Ball Load 150kg

Page 1 of 10

Rev B

07-06-12

www.haymanreese.com.au



HAYMAN REESE
PART No: 02880RW
HYUNDAI i40 WAGON 2011

INSTALLATION INSTRUCTIONS

PLEASE ENSURE THAT INSTRUCTIONS ARE UNDERSTOOD PRIOR TO FITMENT

Warning:

- | | |
|---|--|
| <ol style="list-style-type: none">1. Do not, drill, cut, weld or otherwise modify the towbar.2. If you are using electric welding on a motor vehicle, always check that the vehicle is not equipped with electronic engine or instrument management equipment. Failure to do so could destroy any onboard computers. If in doubt, check with the vehicle's manufacturer. | <p>Rating Braked 1500 Kg
Rating Unbraked 700 Kg
Max Static Ball Load 150 Kg</p> |
|---|--|

General:

1. Ensure all hardware items have been included
2. It is recommended that the instructions are read through and completely understood before making any attempt to fit this product.
3. Be wary of any changes to vehicle designs or other accessories that may conflict with the installation of this product.
4. Before drilling ensure that the area is clear of fuel, electrical & other components.
5. All holes drilled into the body panels shall have all burrs & swarf removed then coated with a suitable rust preventative paint.
6. The high tensile fasteners supplied with this product were used to achieve the specified rating. If replacement is required ensure that fasteners of the same rating & quality are used. Contact an authorised **Hayman Reese** dealer if further information is required.
7. Ensure that all hardware is fastened to torque list below check fasteners on regular basis.
8. Towbar load rating sticker provided with this product shall be conspicuously located on inside rear end of the driver's door. **(See diagram below).**
9. Hayman Reese recommends that you check your tow ball to ensure that it complies with the Australian standards **AS 4177.2**.
10. **PLEASE NOTE:** It is advised to remove your lug or tbn when not actually towing so as to produce a clear view of the vehicles registration plate if obscured, and to also provide maximum available departure angle.

Tow bar Maintenance and Care.

Hayman Reese recommends that bolt torque's, as listed below, are routinely and regularly inspected and checked for correct tension. Replace any worn or defective parts.

We recommended to remove Tow Ball Mounts (TBM's, tongues or lugs) when not being used for any considerable length of time.

So as to avoid injury, when not towing it is suggested that the tongue, Pull Pin and R-clip are removed then stored in a safe, clean and dry place, away from excessive moisture.

Hitch Pull Pins and spring "R" clips are regularly checked for proper installation. Replace any worn or defective parts.



HAYMAN REESE
PART No: 02880RW
HYUNDAI i40 WAGON 2011

INSTALLATION INSTRUCTIONS

PLEASE ENSURE THAT INSTRUCTIONS ARE UNDERSTOOD PRIOR TO FITMENT

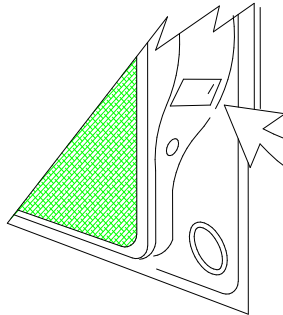

Place load rating sticker
inside driver's door here

RECOMMENDED ASSEMBLY TORQUE LISTING
Diameter Grade 8.8 Bolt

M6	9.5 Nm
M8	21.7 Nm
M10	43.4 Nm
M12	77.3 Nm
M16	189.8 Nm

FOR TOWING PURPOSES ONLY

For towing capacity details please refer to vehicle
owner's manual or to the manufacturer. Overloading
can void your warranties.

ITEM LIST

QTY.	DESCRIPTION	ITEM NO.
1	Towbar	1
1	LHS Chassis Support Bracket	2
1	RHS Chassis Support Bracket	3
1	TBM	4
1	Side Arm Left	5
1	Side Arm Right	6
2	BUMPER BRACKET	7
1	BOLT PACK	8
1	BUMPER TRIM PINCH WELD 400mm	9
4	Cable Tie GT300 UV	10
4	BOLT M6x16	11
8	M6 X 12.5 X 1.2 Z/P BRT FT WASHER	12
4	NYLOC NUT M6-1.00 Z/P	13
5	M10x1.5 HEX NUT PC8	14
1	M10 - 1.5 x 30mm BOLT	15
4	BOLT M10x75X1.5P	16
6	M12x1.25 HEX NUT PC8	17
16	WASHER M12x28.8x3mm	18
10	BOLT M12 - 1.25 x 40mm GR 8.8 Z/P	19
8	Washer Flat M10 x 23 x 2 z/p	20
1	PULL PIN	21
1	SPRING COTTER PIN ASSY	22
2	D' SHACKLE	23
1	Hitch Box Collar Cover	24

HAYMAN REESE
PART No: 02880RW
HYUNDAI i40 WAGON 2011

INSTALLATION INSTRUCTIONS

PLEASE ENSURE THAT INSTRUCTIONS ARE UNDERSTOOD PRIOR TO FITMENT

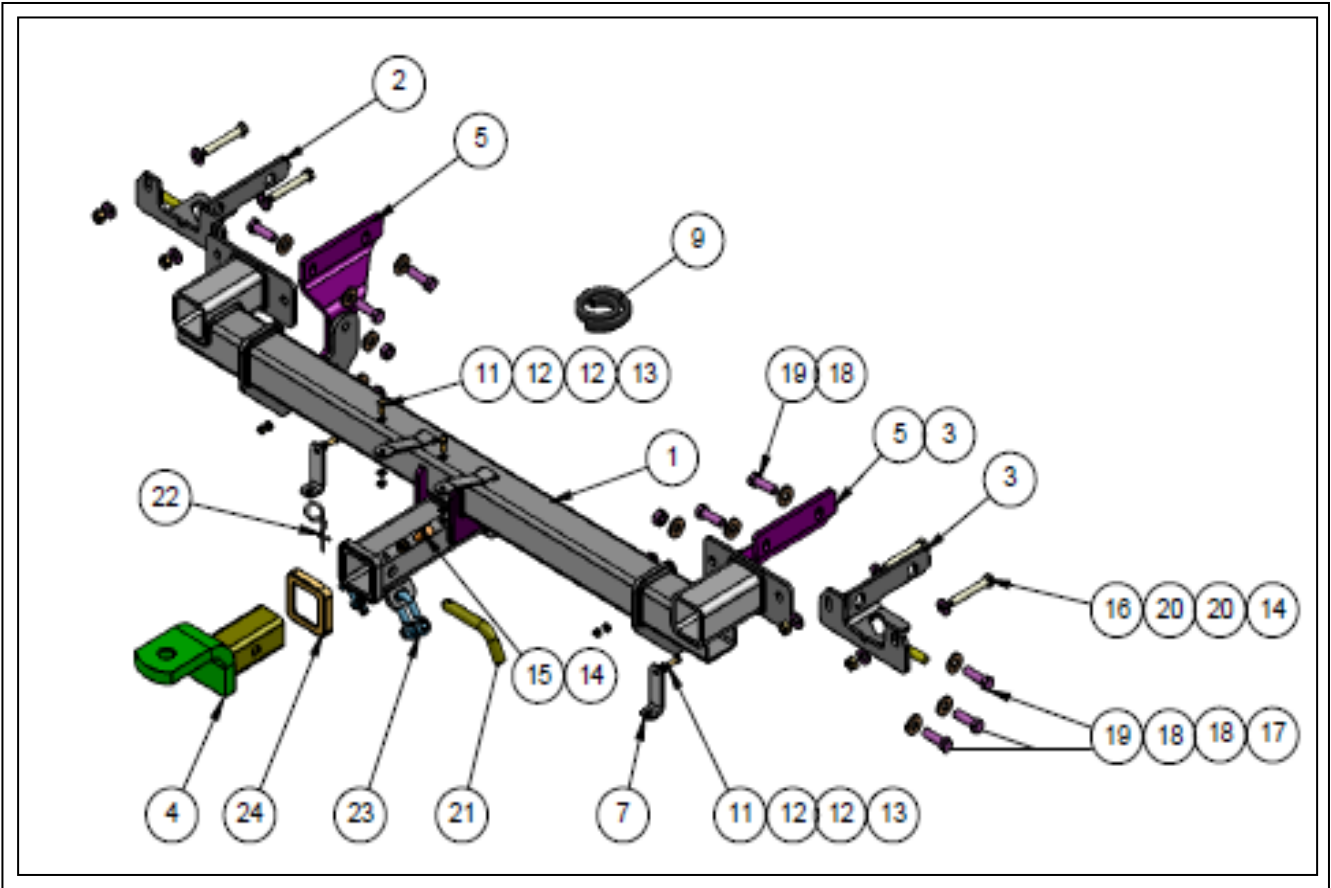

HAYMAN REESE
PART No: 02880RW
HYUNDAI i40 WAGON 2011

INSTALLATION INSTRUCTIONS

PLEASE ENSURE THAT INSTRUCTIONS ARE UNDERSTOOD PRIOR TO FITMENT

1. Open tailgate, remove tabs and undo the 2 screws each side from the tail lights.

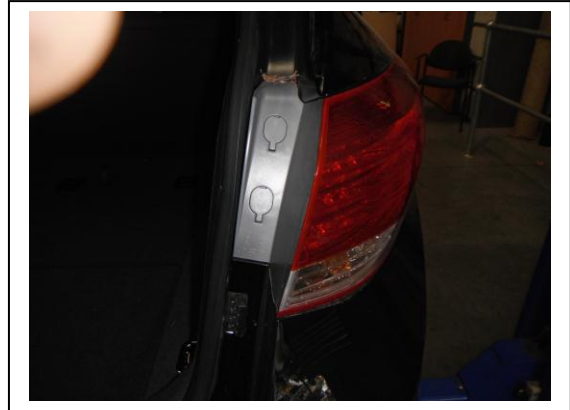

2a. Remove the tail lights, disconnect the indicators globes.
2b. Dislodge the connector grommet and disconnect the tail light connector.



3. Release one screw & one connector from the tail light cavity. Repeat on the other side.



Rev B

Page 5 of 10

07-06-12

HAYMAN REESE
PART No: 02880RW
HYUNDAI i40 WAGON 2011

INSTALLATION INSTRUCTIONS

PLEASE ENSURE THAT INSTRUCTIONS ARE UNDERSTOOD PRIOR TO FITMENT

4a. Release three screws from the wheel arch on each side.
4b. Release two scrivets from the underneath the bottom fascia.



5. Remove three screws and three scrivets from underneath the tray.



6a. Remove the exhaust muffler hanger bracket by removing two nuts and discard.



Rev B

Page 6 of 10

07-06-12

HAYMAN REESE
PART No: 02880RW
HYUNDAI i40 WAGON 2011

INSTALLATION INSTRUCTIONS

PLEASE ENSURE THAT INSTRUCTIONS ARE UNDERSTOOD PRIOR TO FITMENT

7a. Release two nuts from the exhaust flange joint and remove the exhaust muffler.
7b. Remove the exhaust heat shield by removing four nuts.
7c. Cut the exhaust heat shield as per the template provided. (Page 11)

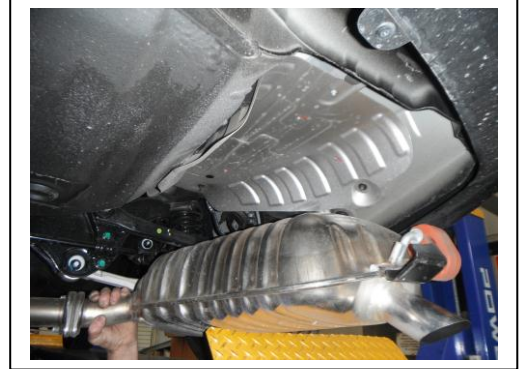

8. Release two nuts each side holding the impact beam.



9. Carefully dislodge the rear bumper bar assembly.
10. Disconnect the wiring harness connector.
11. Disconnect the reverse park sensor if fitted.
12. Remove the bumper bar assembly.
13. Release five scrivets, keep two and discard the rest from the reinforcement beam.
14. Disconnect the reverse connectors if fitted.
15. Release screws and disconnect the smart key antenna.
16. Remove and discard the reinforcement beam.

HAYMAN REESE
PART No: **02880RW**
HYUNDAI i40 WAGON 2011

INSTALLATION INSTRUCTIONS

PLEASE ENSURE THAT INSTRUCTIONS ARE UNDERSTOOD PRIOR TO FITMENT

17. Loosely secure the chassis support bracket and spacer with two M10 bolts and washers. Repeat on the other side.

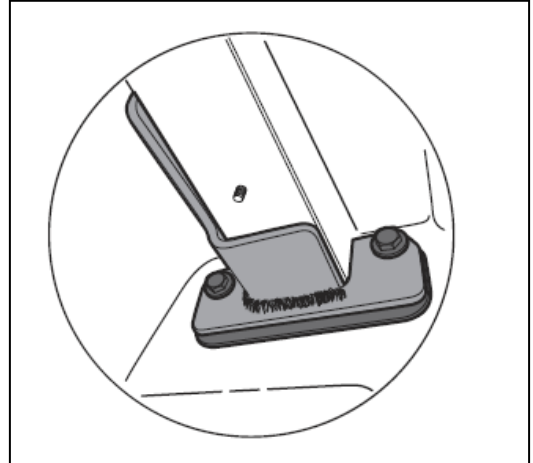

18. Loosely secure RHS chassis side arm to both the chassis support bracket and the side of the chassis rail, using two M12 bolts and two M12 washers. Repeat on the other side.

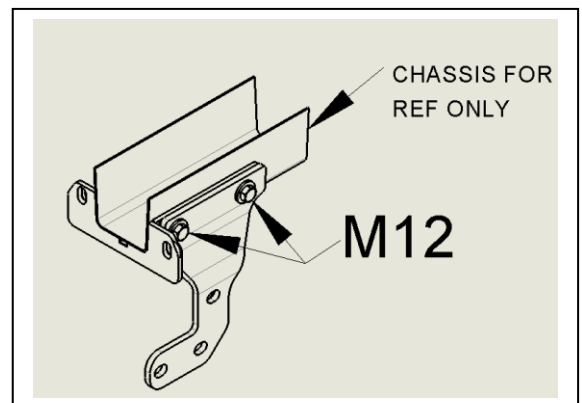

19. Offer the drawbar and loosely secure the towbar with two M10 washers and nuts.



Rev B

Page 8 of 10

07-00-12

HAYMAN REESE
PART No: 02880RW
HYUNDAI i40 WAGON 2011

INSTALLATION INSTRUCTIONS

PLEASE ENSURE THAT INSTRUCTIONS ARE UNDERSTOOD PRIOR TO FITMENT

20. Repeat on the other side as shown.



21. Mount the bumper brackets to the main towbar assembly using 2 M6 bolts and nyloc nuts.



22. Mount the smart key sensor (if fitted) using two M6 bolts, washers and nylon nuts.
23. Reconnect the wiring harness connector removed in step 10.
24. Torque all bolts to the specified torque on page 3.

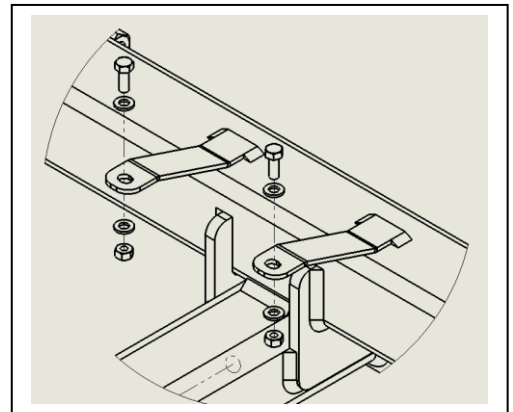

Rev B

Page 9 of 10

07-06-12

HAYMAN REESE
PART No: **02880RW**
HYUNDAI i40 WAGON 2011

INSTALLATION INSTRUCTIONS

PLEASE ENSURE THAT INSTRUCTIONS ARE UNDERSTOOD PRIOR TO FITMENT

25. Cut the Heat shield and the bumper bar on as per the templates provided below.(Page 11 & 12).
26. Refit the exhaust to the muffler hanger on the chassis bracket.
27. Refit the bumper assembly and the tail lights in the reverse order.

28. Attach Hitch box Collar. Secure the TBM with pull pin and spring cotter pin. Attach M10 bolt and nut to the hitch assembly.

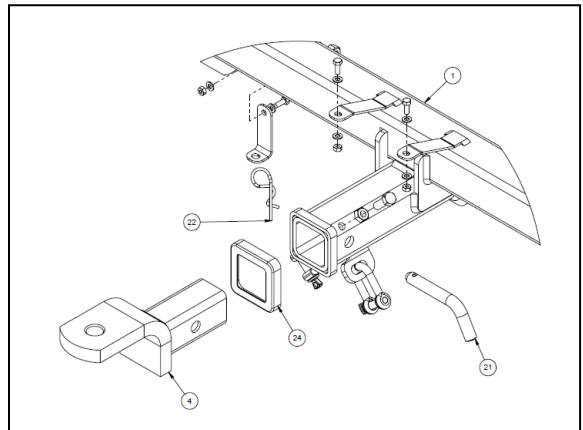

HAYMAN REESE
PART No: 100725-WL
HYUNDAI i40 TOURER

INSTALLATION INSTRUCTIONS

PLEASE ENSURE THAT INSTRUCTIONS ARE UNDERSTOOD PRIOR TO FITMENT

Wiring Loom Installation Instructions

HYUNDAI i40 Tourer
Part No: 100725-WL

Tail Harness Length Required: 1200mm
RPA Override Switch Part No: 04848 (If Fitted)

Note: If factory OEM RPA is fitted, Trouble Code will be logged if disabled.

Wiring Loom Installation Time: Approx. 50 Mins

Hyundai i40 Tourer

Issue Date 12-12-11

Page 1

Part No: 100725-WL

Hayman Reese (Cequent)
PO Box 4050, Dandenong South VIC 3164
Phone 1800 812 017 Email info@haymanreese.com.au

www.haymanreese.com.au



HAYMAN REESE
PART No: 100725-WL
HYUNDAI i40 TOURER

INSTALLATION INSTRUCTIONS

PLEASE ENSURE THAT INSTRUCTIONS ARE UNDERSTOOD PRIOR TO FITMENT

1. In the luggage compartment, remove the cargo net by first removing the two upper hooks and pressing the lower button.
2. Remove the cargo blind by first releasing the two levers located on both the upper RHS and LHS of the cargo blind.
3. Remove the floor carpet cover and fold the rear passenger seats forward.
4. On the RHS of the luggage compartment, remove the storage divider.
5. Remove the front section of the floor carpet.
6. On the rear luggage compartment, remove the centre storage tubs.
7. On the rear luggage compartment, remove the rear trim by first removing the two fir tree clips.
8. On the RHS, in the luggage compartment, remove the compartment rail by first releasing the three 12mm bolts.

Note: The adjustable anchor slugs may need to be moved to gain access to the 12mm bolts.

Repeat for the LHS.

9. On the RHS of the luggage compartment, dislodge the compartment light and disconnect both the light connector and the 12V accessory connector.
10. Dislodge the RHS luggage compartment and pull towards the middle of the vehicle.
11. On the rear quarter of the RHS luggage compartment, remove the existing grommet and drill out a hole to Ø30mm.
12. Ensure to file any rough or sharp edges and spray with rust inhibitor.
13. On the LHS of the luggage compartment, dislodge the compartment light and disconnect the light connector.
14. Dislodge the LHS luggage compartment trim and pull towards the centre of the vehicle.

Issue Date 12-12-11

Page 2

Part No: 100725-WL

Hayman Reese (Cequent)
PO Box 4050, Dandenong South VIC 3164
Phone 1800 812 017 Email info@haymanreese.com.au

www.haymanreese.com.au



HAYMAN REESE
PART No: 100725-WL
HYUNDAI i40 TOURER

INSTALLATION INSTRUCTIONS

PLEASE ENSURE THAT INSTRUCTIONS ARE UNDERSTOOD PRIOR TO FITMENT

15. Inside the vehicle cabin, on the rear passenger side, remove the passenger's seat base by first removing the two 12mm hex head bolts.
16. On the RHS of the rear passenger side, remove the rear scuff plate by first removing the one Phillip head screw.
17. On the RHS of the rear passenger side, remove the 12mm hex head bolt securing the seat bolster.
18. At the front of the driver's RHS, remove the side scuff plate.
19. Carefully dislodge the bonnet release lever and remove the trim clip securing the kick panel.
20. Remove the driver's side kick panel.
21. Inside the vehicle cabin, on the RHS, remove the 'B' pillar trim.
22. Underneath on the driver's lower dash, remove the dash fuse panel access trim.
23. On the LHS of the luggage compartment, disconnect the tail light connector and connect the trailer patch (P/No: 100725-WL) in between.
24. Using a multimeter, locate the vehicle 'BLUE' reverse signal wire.
25. Following the table below, connect the ezy-tap to the vehicle 'BLUE' reverse signal wire.

Function	Trailer Patch	Vehicle Connector
REVERSE	BLACK	BLUE

26. Connect the trailer patch terminal to the ezy-tap.
27. Route the trailer wiring harness across the rear luggage compartment towards the RHS tail light connectors.
28. On the RHS of the luggage compartment, disconnect the tail light connectors and connect the trailer patch in between.
29. Secure the trailer wiring harness ground ring terminal to the existing vehicle ground point using the existing 10mm bolt.



HAYMAN REESE
PART No: 100725-WL
HYUNDAI i40 TOURER

INSTALLATION INSTRUCTIONS

PLEASE ENSURE THAT INSTRUCTIONS ARE UNDERSTOOD PRIOR TO FITMENT

30. Route the power harness from the luggage compartment, past the RHS of the rear passenger's side, towards the front of the vehicle.
31. Ensure to cable tie (not supplied) the power harness to the existing vehicle harness.
32. Continue routing the power harness through the 'B' pillar trim, towards the driver's RHS.
33. Continue routing the power harness along the main vehicle harness into the fuse box, which is located on the lower dash on the RHS of the driver's side.
34. Remove the 30-amp fuse (1) from the fuse panel.
35. Slot in the supplied 15-amp fuse (2) into the upper slot of the add-a-fuse (3) and connect the 30-amp fuse (1) into the lower slot of the add-a-fuse (3).

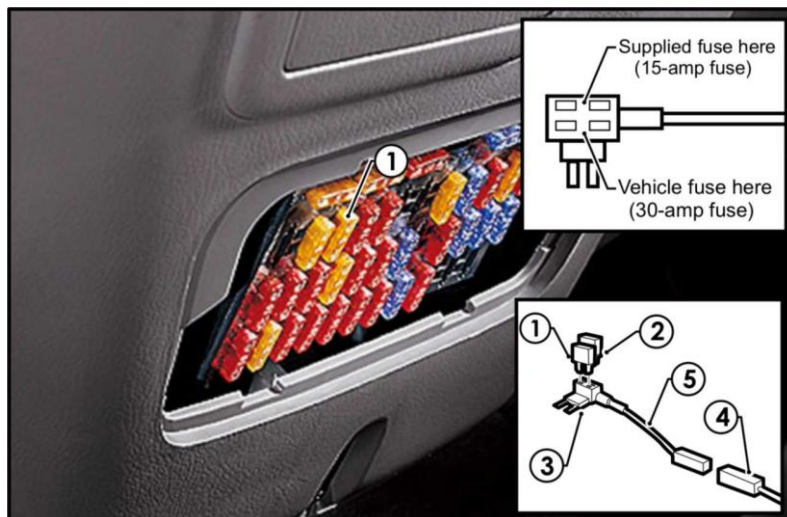

36. Insert the add-a-fuse (3) into the now vacant fuse slot.
37. Connect the trailer patch harness (4) to the add-a-fuse harness (5).
38. From the outside of the vehicle, mount the trailer socket onto the towbar mounting bracket using M4 fasteners (not supplied).
39. Route the tail harness (1200mm tail length) across the towbar towards the RHS of the vehicle and up through the previously drilled out grommet hole.

Issue Date 12-12-11

Page 4

Part No: 100725-WL

Hayman Reese (Cequent)
PO Box 4050, Dandenong South VIC 3164
Phone 1800 812 017 Email info@haymanreese.com.au

HAYMAN REESE
PART No: 100725-WL
HYUNDAI i40 TOURER

INSTALLATION INSTRUCTIONS

PLEASE ENSURE THAT INSTRUCTIONS ARE UNDERSTOOD PRIOR TO FITMENT

40. In the luggage compartment, connect the tail harness 8-way connector to the trailer harness mating 8-way connector.
41. Test the Trailer Harness function using a Light Board or multimeter.
42. Secure all Harnesses using cables ties (not supplied).
43. Re-fit all removed parts and secure all fasteners, ensuring there are no squeaks or rattles.
44. Place the instructions in the glove box after fitment.

Issue Date 12-12-11

Page 5

Part No: 100725-WL

Hayman Reese (Cequent)
PO Box 4050, Dandenong South VIC 3164
Phone 1800 812 017 Email info@haymanreese.com.au

www.haymanreese.com.au

